

Professional

Engineering

Services

Booster Station
Backup
Generators

Contract 2-2026

Project Manual

Village of Oswego

Oswego, Illinois

Issued for Bid

February 3, 2026



TECHNICAL SPECIFICATIONS
VILLAGE OF OSWEGO
OSWEGO, ILLINOIS
BOOSTER STATION BACKUP GENERATORS
CONTRACT 2-2026



Feb 03, 2026
Expires 11/30/2027

Prepared by:

STRAND ASSOCIATES, INC.®
IDFPR No. 184-001273
1170 South Houbolt Road
Joliet, IL 60431
www.strand.com

Issued for Bid
February 3, 2026



SECTION 00 01 10

TABLE OF CONTENTS

VILLAGE OF OSWEGO
OSWEGO, ILLINOIS
BOOSTER STATION BACKUP GENERATORS
CONTRACT 2-2026

Pages
Through

SPECIFICATIONS

DIVISION 01–GENERAL REQUIREMENTS

SUMMARY OF WORK	01 11 00- 5
CONTRACT CONSIDERATIONS	01 29 00- 2
COORDINATION, FIELD ENGINEERING, AND MEETINGS	01 31 00- 3
SUBMITTALS	01 33 00- 7
REGULATORY REQUIREMENTS	01 41 00- 2
REFERENCE STANDARDS AND DEFINITIONS	01 42 00- 6
QUALITY CONTROL	01 45 00- 2
TEMPORARY FACILITIES	01 50 00- 2
FIELD OFFICES AND SHEDS	01 52 13- 2
TEMPORARY CONTROLS	01 57 00- 3
MATERIALS AND EQUIPMENT	01 60 00- 4
CUTTING, PATCHING, AND ALTERATIONS	01 73 29- 5
CONTRACT CLOSEOUT	01 77 00- 3
STARTING OF SYSTEMS	01 91 00- 8
WAGE RATES	8

DIVISION 02–EXISTING CONDITIONS

DEMOLITION	02 41 00- 2
------------------	-------------

DIVISION 03–CONCRETE

CONCRETE FORMWORK	03 11 00- 4
CONCRETE REINFORCEMENT	03 20 00- 4
CAST-IN-PLACE CONCRETE	03 30 00-14

DIVISION 05–METALS

METAL FABRICATIONS	05 50 00- 7
ANCHOR BOLTS AND POST-INSTALLED ANCHORS	05 56 00- 3

DIVISION 09–FINISHES

PAINTING	09 91 00- 8
----------------	-------------

TABLE OF CONTENTS Continued

Pages
Through

DIVISION 20–COMMON FIRE SUPPRESSION, PLUMBING, AND HVAC REQUIREMENTS

IDENTIFICATION FOR FIRE SUPPRESSION, PLUMBING, AND HVAC PIPING AND EQUIPMENT	20 05 53- 3
--	-------------

DIVISION 23–HEATING, VENTILATING, AND AIR CONDITIONING

GENERAL-DUTY VALVES FOR HVAC PIPING	23 05 23- 3
FACILITY FUEL GAS PIPING	23 11 23- 9

DIVISION 26–ELECTRICAL

GENERAL ELECTRICAL REQUIREMENTS	26 05 00- 9
WIRE	26 05 19- 9
INSTRUMENT AND COMMUNICATION WIRE AND CABLE	26 05 23- 3
SUPPORTING DEVICES	26 05 29- 2
CONDUIT	26 05 33- 7
BOXES	26 05 35- 3
ELECTRICAL IDENTIFICATION	26 05 53- 5
SCADA SYSTEM I/O LISTING	26 09 90- 1
OVERCURRENT PROTECTIVE DEVICES	26 28 00- 2
STANDBY POWER SYSTEM.....	26 32 13.1-10
STANDBY POWER SYSTEM–PORTABLE	26 32 13.2-11
GENERATOR DOCKING STATIONS.....	26 36 14- 3
MANUAL TRANSFER GENERATOR DOCKING STATIONS	26 36 15- 3
AUTOMATIC TRANSFER SWITCHES.....	26 36 23- 4

DIVISION 31–EARTHWORK

EXCAVATION, FILL, BACKFILL, AND GRADING	31 23 00- 7
---	-------------

DIVISION 32–EXTERIOR IMPROVEMENTS

WOOD FENCE	32 31 15- 2
RESTORATION.....	32 92 00- 3

DIVISION 33–UTILITIES

FUEL GAS DISTRIBUTION UTILITIES	33 52 16- 8
NATURAL GAS CONTRACTOR QUALIFICATION REQUIREMENT	33 52 26- 3

DRAWINGS

STANDARD DETAIL–SANITARY SEWER APPURTENANCES.....	01-975-43A
---	------------

END OF SECTION

SPECIFICATIONS

SECTION 01 11 00

SUMMARY OF WORK

PART 1–GENERAL

1.01 DIVISION ONE

- A. The requirements of Division 01 apply to all sections of the Contract.

1.02 PROJECT SCOPE

- A. CONTRACTOR shall provide all items, articles, materials, operations or methods mentioned or scheduled on the Drawings or herein specified: including all labor, supervision, equipment, incidentals, taxes, and permits necessary to complete the Work as described within the Contract Documents. CONTRACTOR shall install all items provided by OWNER as mentioned or scheduled on the Drawings or herein specified.

1.03 CONTRACT DOCUMENTS–INTENT AND USE

A. Intent of Documents:

1. Singular notations and Specifications shall be considered plural where application is reasonably inferred.
2. Mention or indication of extent of work under any division or Specification section is done only for convenience of CONTRACTOR and shall not be construed as describing all work required under that division or section.
3. Some individual sections may contain a list of related sections. The list of related sections in individual sections is provided for the convenience of CONTRACTOR and is not necessarily all-inclusive. CONTRACTOR may not rely upon this listing for determination of scope of work. Other sections of the Specifications not referenced in individual sections shall apply as required for proper performance of the Work.
4. Command type sentences may be used in the Contract Documents. These sentences refer to and are directed to CONTRACTOR.
5. Symbols for various elements and systems are shown on the Drawings. Should there be any doubt regarding the meaning or intent of the symbols used, a written interpretation shall be obtained from ENGINEER.

B. Use of Documents:

1. CONTRACTOR shall examine all Specifications and Drawings for the Work, including those that may pertain to Work CONTRACTOR does not normally perform with its own forces.
2. CONTRACTOR shall use all of the Project Drawings and Specifications:
 - a. For a complete understanding of the Project.
 - b. To determine the type of construction and systems required.
 - c. For coordination with other contractors.
 - d. To determine what other work may be involved in various parts or phases.
 - e. To anticipate and notify others when work by others will be required.
 - f. And all other relevant matters related to the project.
3. CONTRACTOR is also bound by all requirements of the Contract Documents which are applicable to, pertain to, or affect its Work as may be shown or inferred by the entire set of Project Drawings and Specifications.

1.04 CONSTRUCTION REQUIREMENTS

- A. In general, the following contract completion Milestones shall be followed. See Agreement for specific dates:
1. Milestone 1 Completion: CONTRACTOR shall by that date, have completed and placed in service Booster Station No. 4 Manual Transfer Generator Docking Station.
 2. Milestone 2 Completion: CONTRACTOR shall by that date, have completed and placed in service Booster Station No. 2 Generator Docking Station and Portable Generator.
 3. Milestone 3 Completion: CONTRACTOR shall by that date, have completed and placed in service Booster Station No. 3 Natural Gas Generator and Automatic Transfer Switch.
 4. Final Completion: CONTRACTOR shall by June 30, 2027, have the Project completed.
- B. General Information and Requirements:
1. Normal working hours are 7 A.M. until 3:30 P.M., Monday through Friday.
 2. The Village of Oswego operates the booster station facilities on a 24/7 basis. However, one booster station facility may be removed from service for a time as allowed by OWNER.
 3. Operation of the booster station facilities will be the responsibility of OWNER. CONTRACTOR shall cooperate with the water utility operation staff at all times, and removal of any water storage facility from service shall be coordinated by CONTRACTOR with OWNER and ENGINEER. CONTRACTOR shall notify OWNER in writing a minimum of 72 hours (not including weekends and OWNER's holidays) prior to removing any booster station facility from service.
 4. Unless allowed by OWNER in writing, no more than one facility may be taken out of service at a time. CONTRACTOR shall coordinate taking a facility out of service and placing the facility back in service with OWNER. Unless allowed by OWNER in writing, all facilities shall be returned to normal operation by 3 P.M. each day and shall not be out of service longer than six hours.
 5. CONTRACTOR shall not commence work on any alternative until requesting and obtaining OWNER's written authorization.
 6. CONTRACTOR shall maintain plant site roadways open at all times to meet OWNER's requirements. Access by roadway to other facilities shall be maintained, except as approved by OWNER. CONTRACTOR shall be responsible for maintaining roadways in drivable conditions.
 7. Outage Plan: CONTRACTOR shall submit for review, a detailed outage plan which includes time scheduled for work activities necessary to remove electric service from each facility. The plan shall be in writing and also in the form of a bar graph. The outage plan shall be coordinated with the work construction schedule and shall be updated monthly. The outage plan shall include the length of time required to complete said work. The length of time each facility is out of service shall be minimized. To that end, all new equipment, tools, and materials required for the Work shall be readily available when outage is implemented to minimize down time of the facility.
- C. Construction Sequence:
1. The following construction sequence is provided as a general guideline for the information and for the benefit of CONTRACTOR. This construction sequence is not intended to dictate means, method of construction, or direct construction activities. This construction sequence is a conceptual general construction sequence with minimum recommended outage, shutdowns, and operating units to be maintained in service. The general construction sequence is projected to allow the Work to be completed while maintaining treatment of each booster station. It is not intended to be all inclusive and does not list all work elements or details that are required to complete the Work,

- complete treatment processes, or place unit processes in service. CONTRACTOR shall be responsible for implementing any additional details required, including temporary piping, bypass pumping, or temporary construction at no additional cost to OWNER.
2. CONTRACTOR may propose alternate sequence or modifications to this sequence. OWNER will review the proposed modification and determine if such modification of the sequence interferes with the proper operation of the booster stations. Any modifications to this general construction sequence shall be proposed in writing and shall be approved by OWNER prior to their implementations.
 3. At any time, construction activity may commence for Booster Station No. 2 and Booster Station No. 4. Coordination with the gas utility is required to commence construction activities for Booster Station No. 3.
 4. A maximum of one Booster Station shall be offline at any time during construction. Coordinate with OWNER before station is taken offline.

1.05 CONTRACTOR USE OF SITE

A. General:

1. The "area of the site" referred to in these Specifications shall be as shown on the Drawings. If the "area of the site" is not shown, OWNER's property lines, the Project right-of-way and/or any easements obtained for the Project shall be considered the "area of the site."
2. Construction activities shall be confined within the "area of the site" limits.
3. From the start of work to completion CONTRACTOR is responsible for the care of the site and the premises which are affected by operations of Work of this Contract.
4. Except for permanent site improvements provided under the Contract, CONTRACTOR shall restore property disturbed during the Work, to the conditions which previously existed.
5. Work in occupied spaces shall be restricted to specified Work and essential activities, such as making necessary connections and extending services or constructing temporary access ways. Such work shall be scheduled in advance with OWNER.

B. Parking and Deliveries:

1. CONTRACTOR is responsible for control of traffic by vehicles and persons within the limits of its operations.
2. Parking for employees, subcontractors, and agents of CONTRACTOR shall be in areas subject to approval of OWNER.
3. Access to the site for delivery of construction material or equipment shall be subject to approval of OWNER.

1.06 EXISTING SERVICES, OVERHEAD UTILITIES, AND UNDERGROUND FACILITIES INCLUDING STRUCTURES

- A. Interruption of existing services and systems including heating, ventilating, air conditioning, water, lighting and power, signal and security systems, and similar work shall be kept to an absolute minimum and shall be limited to times approved by OWNER.
- B. If deemed necessary by OWNER, such work shall be accomplished after OWNER's normal office hours.
- C. Work shall not commence until all labor, materials, and equipment are available so Work can continue without interruption or delay.

- D. Should uncharted or incorrectly charted services or Underground Facilities be encountered during installation, notify OWNER and consult with utility owner immediately.
- E. Cooperate with OWNER and utility companies in keeping respective services and Underground Facilities in operation and repair any damage.
- F. CONTRACTOR shall not interrupt existing services and Underground Facilities occupied and used by OWNER or others, except when permitted in writing by OWNER.
- G. Any accidental interruption of services and Underground Facilities shall be repaired immediately, including provision of temporary facilities until permanent repairs can be made.
- H. Prior to any excavation, demolition, or drilling on site, CONTRACTOR shall contact owners of the Underground Facilities in and near the construction area of the intent to excavate, demolish, or drill. As part of this notification requirement, CONTRACTOR shall contact "JULIE" (811 or 1-800-892-0123). CONTRACTOR shall be aware that not all owners participate in "JULIE." A call to this agency shall not absolve CONTRACTOR of the requirements for contacting owners of all Underground Facilities in and near the construction area. CONTRACTOR shall give reasonable advance notice to "JULIE" and other owners for the notification which shall not be less than the minimum advance notification required.
- I. Locations and elevations of services and Underground Facilities as shown on the Drawings are approximate. It shall be CONTRACTOR's responsibility to determine their exact location when in their vicinity. To this end, CONTRACTOR shall proceed with caution in the excavation and preparation of the Site so the exact location of services and Underground Facilities can be determined. CONTRACTOR shall include in the Contract Price any costs for temporary or permanent relocations of such services and Underground Facilities required to complete the Work unless specifically indicated otherwise in the Specifications.
- J. Where potential grade conflicts might occur with existing services and Underground Facilities, CONTRACTOR shall uncover such services and Underground Facilities sufficiently in advance of construction so that elevations may be determined to allow any necessary adjustments to be made.
- K. CONTRACTOR shall coordinate with overhead utility companies prior to the Work. CONTRACTOR shall provide all necessary temporary and permanent support relocation or temporary and permanent restraint to maintain overhead utilities in service.
- L. CONTRACTOR shall keep an accurate and complete record of all such services and Underground Facilities encountered and shall provide OWNER a copy of this record. The record shall include a description of the item encountered, opinion as to conditions, and adequate measurements and depths so that the item can be located in the future.
- M. CONTRACTOR shall inspect all services and Underground Facilities for condition and soundness. Unsound conditions shall be reported to OWNER immediately after exposing. CONTRACTOR shall not proceed with the Work until the service or facility owner has been notified. Service or facility owner shall then be given time to inspect and correct, if required, the service or Underground Facility. CONTRACTOR may make claim under the provisions of the Contract Documents should CONTRACTOR feel a price or time adjustment is justified.

- N. Any additional costs incurred because of failure of CONTRACTOR to report the condition of any and all existing services and Underground Facility encountered shall be paid for by CONTRACTOR.
- O. Whenever ENGINEER feels it is necessary to explore and excavate to determine the location of existing services and Underground Facilities, CONTRACTOR shall make explorations and excavations for such purposes. If CONTRACTOR is required to perform additional Work in making the explorations and excavations, extra compensation will be allowed as provided for in the Contract Documents.

1.07 PROTECTION OF WORK AND IMPROVEMENTS

- A. CONTRACTOR shall protect the property of OWNER, existing improvements, and the Work installed by CONTRACTOR and others from abuse, damage, dust, debris, and other objectionable materials resulting from construction activities.
- B. CONTRACTOR shall provide suitable covers, partitions, or other dust and fume containment devices to suit construction operations.
- C. CONTRACTOR shall keep property, existing improvements, and the Work including structures, mains, fittings, and accessories free from dirt and foreign matter at all times.
- D. CONTRACTOR shall provide temporary plugging of openings, holes, and pipe ends that are existing or that CONTRACTOR has installed.
- E. Property, improvements, and Work damaged by CONTRACTOR shall be repaired or replaced by CONTRACTOR to the satisfaction of OWNER.
- F. CONTRACTOR is cautioned that existing private and public roads and shoulders may not hold up to typical construction traffic or activities. CONTRACTOR shall replace all roads, shoulders, and paved areas damaged during the project in accordance with this section. Gravel shoulders, gravel roads, and parking areas shall be repaired to match preconstruction conditions.

1.08 AVAILABILITY OF LANDS

- A. Easements were not obtained for this Project. CONTRACTOR shall confine its operations, equipment and storage areas to the lands and rights-of-way in which the Project is to be located. CONTRACTOR may enter into written agreements with property owners for use of other lands during construction. Copies of such agreements shall be provided to OWNER.

PART 2–PRODUCTS

NOT APPLICABLE

PART 3–EXECUTION

NOT APPLICABLE

END OF SECTION

SECTION 01 29 00

CONTRACT CONSIDERATIONS

PART 1–GENERAL

1.01 SUMMARY

- A. Work Included: Measurement and Payment–Lump Sum.

1.02 MEASUREMENT AND PAYMENT–LUMP SUM

- A. Payment for Lump Sum projects will be based on the accepted schedule of values for the project.
- B. An acceptable schedule of values will include the following features:
 - 1. Schedule shall list the installed value of the component parts of the work in sufficient detail to serve as a basis for computing values for progress payments during construction. Schedule shall be subdivided as necessary by specification section and work area.
 - 2. Identify each line item with the number and title of the respective Specification Section.
 - 3. For each major line item list sub-values of major products or operations under the item.
 - 4. For the various portions of the work:
 - a. Each item shall include a directly proportional amount of CONTRACTOR's overhead and profit.
 - b. For items on which progress payments will be requested for stored materials, break down the value into:
 - (1) The cost of the materials, delivered and unloaded, with taxes paid. Paid invoices are required for materials upon request by ENGINEER.
 - (2) The total installed value.
 - 5. The sum of all values listed in the schedule shall equal the total Contract Sum.
 - 6. Schedule shall include a separate listing of general items such as bonds, insurance, mobilization, demobilization, field supervision, record documents, and cash allowances.
- C. Once a schedule of values is accepted, it shall not be revised, except for changes associated with subsequently executed change orders.
- D. No separate measurement for payment will be performed for Lump Sum Work.
- E. CONTRACTOR shall estimate percentage of Work completed. ENGINEER will review CONTRACTOR's estimate of quantity of Work completed.
- F. Payment will be made based on the percentage of the Contract completed less retainage and/or liquidated damages.
- G. Unless noted otherwise, all Work described in the Specifications and/or shown on the Drawings shall be included in the Lump Sum Bid.
- H. Some technical specification sections may include payment provisions. These provisions are in addition to the provisions of this section which apply to all of the Work.

PART 2-PRODUCTS

NOT APPLICABLE

PART 3-EXECUTION

NOT APPLICABLE

END OF SECTION

SECTION 01 31 00

COORDINATION, FIELD ENGINEERING, AND MEETINGS

PART 1–GENERAL

1.01 SUMMARY

- A. Work Included:
 - 1. Coordination.
 - 2. Field Engineering.
 - 3. Progress Meetings.
 - 4. Preinstallation Meeting.

1.02 COORDINATION

- A. CONTRACTOR shall coordinate scheduling, submittals, and work of the various sections of the work to provide an efficient and orderly sequence of installation of interdependent construction elements, with provisions for accommodating items installed later. See Section 01 11 00–Summary of Work for specific construction sequence.
- B. CONTRACTOR shall verify utility requirements and characteristics of operating equipment are compatible with building utilities and coordinate Work of various sections having interdependent responsibilities for installing, connecting to, and placing in service such equipment.
- C. CONTRACTOR shall coordinate space requirements and installation of mechanical and electrical work which are indicated diagrammatically on the Drawings and shall follow routing shown for pipes, ducts, and conduit as closely as practicable; place runs parallel with line of building. Utilize spaces efficiently to maximize accessibility for other installations, for maintenance, and for repairs.
- D. In finished areas, except as otherwise indicated, CONTRACTOR shall conceal pipes, ducts, and wiring within the construction and coordinate locations of fixtures and outlets with finish elements.
- E. CONTRACTOR shall coordinate completion and cleanup of Work of separate sections in preparation for substantial completion and for portions of Work designated for OWNER's occupancy.
- F. After OWNER occupancy of premises, CONTRACTOR shall coordinate access to Site for correction of defective Work and Work not in accordance with Contract Documents to minimize disruption of OWNER's activities.

1.03 FIELD ENGINEERING

- A. CONTRACTOR shall locate and protect property stakes, legal survey monuments, benchmarks, and survey control and reference points. CONTRACTOR shall pay for replacement of disturbed property stakes and legal survey monuments by a Registered Land Surveyor acceptable to OWNER and for replacement of benchmarks and survey control and reference points provided by ENGINEER.

- B. CONTRACTOR shall provide field engineering services as required to establish elevations, lines, and levels utilizing recognized engineering survey practices.
- C. CONTRACTOR shall furnish all required plummets and graduated poles to check all Work.
- D. If stakes and boards have to be reset because of negligence of CONTRACTOR, CONTRACTOR shall bear the cost of such work.
- E. If laser beam is used, CONTRACTOR shall check its Work against intermediate grade stakes provided between manholes. Prior to initial use of the laser, CONTRACTOR shall set up laser on ground surface and check line and gradient controls. Lasers not functioning properly shall be immediately removed.
- F. CONTRACTOR shall be responsible for all lines, elevations, and measurements of buildings, structures, piping, utilities, and other work executed by CONTRACTOR under the Contract. CONTRACTOR must exercise proper precaution to verify figures before laying out the Work and will be held responsible for any error resulting from its failure to exercise such precaution.

1.04 PROGRESS MEETINGS

- A. Progress meetings will be held throughout progress of the Work at intervals agreed to by OWNER, ENGINEER, and CONTRACTOR. Interval will generally be monthly.
- B. CONTRACTOR's project manager, job superintendent, major subcontractors, and suppliers shall attend as appropriate to address agenda topics for each meeting. CONTRACTOR's representatives shall have authority to bind CONTRACTOR to decisions at the meetings.
- C. The project schedule shall be updated monthly and shall be reviewed at each progress meeting.
- D. CONTRACTOR shall also provide the following information in written form at each meeting.
 - 1. Construction progress, including:
 - a. Activities completed this reporting period.
 - b. Activities in progress this reporting period.
 - c. Activities scheduled to commence this reporting period.
 - 2. Description of problem areas.
 - 3. Current and anticipated delays.
 - a. Cause of the delay.
 - b. Corrective action and schedule adjustments to correct the delay.
 - c. Impact of the delay on other activities, on milestones, and on completion dates.
 - 4. Changes in construction sequence.
- E. ENGINEER will prepare and distribute minutes to all attending parties.

1.05 PREINSTALLATION MEETING

- A. When required in individual specification sections, CONTRACTOR shall convene a preinstallation meeting at Work Site prior to commencing Work of the section.

- B. CONTRACTOR shall require attendance of parties directly affecting or affected by work of the specific section.
- C. CONTRACTOR shall notify ENGINEER seven days in advance of meeting date.
- D. CONTRACTOR shall prepare agenda and preside at meeting:
 - 1. Review conditions of installation, preparation, and installation procedures.
 - 2. Review coordination with related work.
- E. CONTRACTOR shall record minutes and distribute copies to participants and those affected by decisions made within one week after meeting.

PART 2-PRODUCTS

NOT APPLICABLE

PART 3-EXECUTION

NOT APPLICABLE

END OF SECTION

SECTION 01 33 00

SUBMITTALS

PART 1—GENERAL

1.01 SUMMARY

- A. Work Included:
 - 1. Whenever possible throughout the Contract Documents, the minimum acceptable quality of workmanship and materials has been defined either by manufacturer's name and catalog number or by reference to recognized industry standards.
 - 2. To facilitate CONTRACTOR's understanding of the design intent, procedures have been established for advance submittal of design data and for its review or rejection by ENGINEER.
 - 3. The type of submittal requirements specified in this section include construction progress schedule, submittal schedule, shop drawings, product data, samples, maintenance manuals, and other miscellaneous work-related submittals.
- B. Related work described elsewhere: More detailed requirements for submittals are described in other sections of these Specifications for some materials and equipment. They are to be considered additional requirements to supplement the requirements specified in this section.
- C. Definitions: "Electronic Submittal" is defined as any submittal transmitted electronically to ENGINEER for review.

1.02 IDENTIFICATION OF SUBMITTALS

- A. CONTRACTOR shall completely identify each submittal and resubmittal by showing at least the following information:
 - 1. Name and address of submitter, plus name and telephone number of the individual who may be contacted for further information.
 - 2. Name and location of project and identification number.
 - 3. Drawing number and Specifications section number to which the submittal applies.
 - 4. Include the date of each submittal or resubmittal.

1.03 GROUPING OF SUBMITTALS

- A. Unless otherwise specifically permitted by ENGINEER, CONTRACTOR shall make all submittals in groups containing all associated items so that information is available for checking each item when it is received.
- B. Partial submittals may be rejected as not complying with the provisions of the Contract Documents.

1.04 TIMING OF SUBMITTALS

- A. CONTRACTOR shall make all submittals far enough in advance of scheduled dates of installation to provide required time for reviews, for securing necessary approval, for possible revision and resubmittal, and for placing orders and securing delivery.

- B. The review period for submittals that are received after 3 P.M. shall commence on the following business day.

1.05 CONSTRUCTION PROGRESS AND SUBMITTAL SCHEDULES

- A. Submit preliminary schedules within 10 days of the Effective Date of the Contract.
- B. Revise schedules incorporating any comments provided at the preconstruction conference and resubmit.
- C. As a minimum, the construction progress schedule shall consist of a horizontal bar chart with a separate line for each major portion of Work or operation, identifying first workday of each week.
- D. Show complete sequence of construction by activity, identifying Work of separate stages and other logically grouped activities. Indicate the early and late start, early and late finish, float (defined as the amount of time an activity can be delayed without impacting completion deadlines), and duration for each activity. Identify activities that are on the critical path.
- E. Include line items for milestones (if any), Substantial, and Final Completion.
- F. Submit updated schedules with each Application for Payment, identifying changes since previous version.
- G. Indicate estimated percentage of completion for each item of Work at each submission.
- H. Indicate submittal dates required for shop drawings, product data, samples, and product delivery dates.

1.06 SHOP DRAWINGS

- A. Shop drawings shall include specially prepared technical data for this project including drawings, diagrams, performance curves, data sheets, schedules, templates, patterns, reports, calculations, instructions, measurements, and similar information not in standard printed form for general application to a range of similar projects. Shop drawings shall be submitted for all manufactured or fabricated items. See individual technical sections for special requirements.
- B. CONTRACTOR shall make all shop drawings accurately to scale and sufficiently large to show all pertinent aspects of the item and its method of connection to the work.
- C. Shop drawings shall be checked, approved, and stamped by CONTRACTOR before transmittal to ENGINEER for review and approval.
- D. Complete shop drawings and descriptive data shall be submitted on all manufactured or fabricated items prior to 50% completion of the Work. Applications for payment beyond 50% of the Contract amount will not be recommended for payment until all shop drawings are submitted, including color hard copies if requested by OWNER, or a revised schedule for any remaining submittals is agreed to by OWNER and ENGINEER.
- E. CONTRACTOR shall submit shop drawings following the electronic submittal procedure described below.

- F. Shop drawings submitted to ENGINEER will be reviewed and stamped “Approved,” “Approved as Noted,” “Approved as Noted-Resubmit,” or “Not Approved.” CONTRACTOR shall resubmit shop drawings stamped “Approved as Noted-Resubmit” and “Not Approved,” and will continue this process until shop drawings are stamped “Approved” or “Approved as Noted.” If Drawings are stamped “Approved as Noted-Resubmit,” fabrication may proceed in accordance with the marked-up shop drawings. Installation shall not proceed until shop drawings have been resubmitted and stamped “Approved” or “Approved as Noted.”
- G. If shop drawings are stamped “Approved as Noted” or “Approved as Noted-Resubmit” and CONTRACTOR does not agree with revisions or cannot conform with revisions, fabrication shall not proceed and shop drawings shall be resubmitted with explanation of CONTRACTOR’s position.
- H. All shop drawings used for construction site activities shall bear the “Approved” or “Approved as Noted” stamp of ENGINEER.
- I. CONTRACTOR is fully responsible for obtaining any and all copyright permission associated with conversion of shop drawing information to electronic format.
- J. PDF Submittal Procedures:
 - 1. Summary:
 - a. Shop drawing and product data submittals shall be transmitted to ENGINEER in electronic (PDF) format.
 - b. The intent of PDF submittals is to expedite the construction process by reducing paperwork, improving information flow, and decreasing turnaround time.
 - c. The PDF submittal process is not intended for color samples, color charts, or physical material samples.
 - 2. Procedures:
 - a. CONTRACTOR shall review and apply a stamp certifying that the submittal complies with the requirements of the Contract Documents including verification of manufacturer/product, dimensions and coordination of information with other parts of the work.
 - b. CONTRACTOR shall transmit each cover letter and submittal to ENGINEER as an e-mail attachment.
 - c. ENGINEER will return the reviewed shop drawing via e-mail with a transmittal letter, after review, indicating the status of the shop drawing review.
 - d. Distribution of reviewed submittals to subcontractors and suppliers is the responsibility of CONTRACTOR.
 - e. Electronically submitted shop drawings shall follow the following format:
 - (1) Filenames for the shop drawing submittals shall follow a XX XX XX.YYY-Z. Description convention where XX XX XX is the Specification section number, YYY is the submittal number, .Z is the resubmittal number, and description is a short description of what the submittal includes. Submittals shall be consecutively numbered in direct sequence of submittal. Resubmittals shall be consecutively numbered with the first submittal numbered with a -0 and the first resubmittal numbered with a -1. Example file name: 03 20 00.016-1. Structure 10 Concrete Reinforcement. This would be the first revision of the sixteenth submittal and contain information on concrete reinforcement.
 - (2) All files shall be delivered in PDF format with a minimum resolution of 300 dpi unless otherwise requested by ENGINEER. Scanned in material shall be

scanned in color and any markings by CONTRACTOR shall be made in red. Pages shall be rotated to the appropriate position for easy reading on a computer monitor such that the majority of text is vertical.

- (3) Files shall be delivered without security features activated.
- (4) Shop Drawings shall be uploaded as individual files. All pages of one submittal should be contained in one file.
- (5) The file shall open to a cover page containing, at a minimum, the following information:
 - (a) CONTRACTOR's stamp.
 - (b) Name, e-mail, and telephone number of the individual who may be contacted for further information.
 - (c) Project number.
 - (d) Submittal number.
 - (e) Submission date, if resubmittal, all previous submission dates.
 - (f) Index detailing contents and the total number of pages in the submittal.

K. Shop drawings shall include verification that the item meets applicable codes and standards.

1.07 PRODUCT DATA

- A. CONTRACTOR shall provide product data as required to supplement shop drawings.
- B. Product data are illustrations, standard schedules, performance charts, instructions, brochures, diagrams, and other information furnished by CONTRACTOR to illustrate a material, product, or system for some portion of the work.
- C. CONTRACTOR shall collect required product data into one submittal for each unit of work or system.
- D. CONTRACTOR shall include manufacturer's standard printed recommendations for application and use, compliance with standards, performance characteristics, wiring and piping diagrams and controls, component parts, finishes, dimensions, required clearances, and other special coordination requirements.
- E. CONTRACTOR shall mark each copy of standard printed data to identify pertinent products, models, options, and other data.
- F. CONTRACTOR shall supplement manufacturer's standard data to provide information unique to the work.

1.08 RESUBMISSION REQUIREMENTS

- A. Make any corrections or changes in the submittals required by ENGINEER.
- B. Shop Drawings and Product Data:
 1. Revise initial drawings or data and resubmit as specified for initial submittal.
 2. Itemize in a cover letter any changes which have been made other than those requested by ENGINEER.
- C. CONTRACTOR shall furnish required submittals with sufficient information and accuracy in order to obtain required approval of an item with no more than three submittals. ENGINEER will record ENGINEER's time for review subsequent submittals of shop drawings, samples,

or other items required for approval and CONTRACTOR shall reimburse OWNER and ENGINEER's charges for such time.

- D. In the event that CONTRACTOR requests a substitution for previously approved item, CONTRACTOR shall reimburse OWNER for ENGINEER's charges for its review time unless the need for such change is beyond control of CONTRACTOR.

1.09 MANUFACTURER'S DIRECTIONS

- A. Manufactured articles, materials, and equipment shall be stored, commissioned, operated, applied, installed, connected, erected, used, cleaned, and conditioned as directed by the manufacturer, unless specified to the contrary.
- B. Wherever Specifications call for work to be performed or materials to be installed in accordance with the manufacturer's printed instructions or directions, CONTRACTOR shall furnish copies as required for shop drawings of those instructions or directions to ENGINEER before installing the material or performing the work.

1.10 MAINTENANCE MANUAL

- A. Prior to 75% completion of the Contract or at a minimum of 45 days prior to the scheduled start-up date of any individual item of equipment, whichever is earlier, CONTRACTOR shall furnish to ENGINEER two complete color hard copies of a maintenance manual for all equipment furnished. Applications for payment beyond 75% of the contract amount will not be recommended for payment until all maintenance manuals are submitted or a revised schedule for remaining maintenance manuals is agreed to by OWNER and ENGINEER.
- B. The manuals shall include manufacturer's instructions for maintenance and operation for each item of mechanical and electrical equipment. Manuals shall be specific for the equipment as installed; provide project specific inserts as required. Manuals shall contain: operation instructions, lubrication schedules, types and quantities, preventative maintenance program, spare parts list, parts lists, I.D. No. and exploded views, assembly instructions, parts supplier location, trouble shooting and startup procedures and, where applicable, test data and curves.
- C. All sheets shall have reduced dimensions as described for shop drawings, and shall be furnished in 3-ring binders or 3-tab report covers.
- D. CONTRACTOR is responsible for producing an electronic version of the Equipment Operations and Maintenance (O&M) Manuals Manual. The Electronic Equipment O&M Manual shall be delivered in Portable Document Format (PDF). The entire manual may be converted to PDF via scanning or other method of conversion. Drawings or other graphics must be converted to PDF format and made part of the PDF document. CONTRACTOR shall provide all Equipment O&M Manuals in the electronic format as defined below.
- E. The filename for the Equipment O&M Manual submittal will be provided with the request for final Equipment O&M Manuals. Filenames use the "eight dot three" convention (XX XX XX_YY.PDF) where XX XX XX is the specification section number and YY is an ID number. No one file shall be larger than 10 MB. If technical problems require that the submittal be divided into more than one file, a letter extension shall be added to the end of each filename.

- F. The number of files shall be kept to a minimum. Equipment O&M Manuals that span more than one file shall have the final Bookmark "Return to Table of Contents" which shall take the User to the first file on the Equipment O&M Manual.
- G. All text (word processed), spreadsheets, and electronic graphics shall be delivered in portable document format (*.PDF). The resolution of all scanned images shall be a minimum of 300 dpi unless otherwise requested by ENGINEER. Scanned images shall be processed with the "original image with hidden text" option (Adobe Acrobat 6 or higher). This results in a clear image and provides for optical character recognition (OCR) and word search functionality. Graphical files shall be fully searchable. All submittals must be indexed with the Adobe Catalog feature. Placement and structure of index files shall be in accordance with Adobe's recommendations to minimize problems when transferring files. Successful searches for words or strings in the PDF document shall demonstrate proof of OCR.
- H. Rotate pages viewed in landscape to the appropriate position for easy reading on a computer monitor.
- I. Bookmarks shall be created in the navigation frame for each entry in the Table of Contents. Three levels deep is usually enough (i.e., "Chapter," "Section," "Subsection"); however, complex submittals like instrumentation and electrical may be required at the discretion of ENGINEER. When setting bookmarks for Chapter level heading, the page shall be displayed at Full Page. Section and Subsection level heading pages shall be displayed as a magnified view. Bookmarks shall be displayed as subordinate to other bookmarks in their hierarchy set so that only the Chapter level headings are displayed.
- J. Thumbnails shall be generated and embedded in each PDF file.
- K. Files shall be delivered without Security features activated. Password protected files will be unacceptable.
- L. The opening view for PDF files shall be set as follows:
 - 1. Initial View: Bookmarks and Page
 - 2. Magnification: Fit In Window
 - 3. Page Layout: Single Page
- M. The file shall open to the cover page of the Equipment O&M Manual with bookmarks to the left. The first bookmark shall be the name of Equipment O&M Manual.
- N. O&M Manual shall be delivered on USB flash drive after all equipment O&M Manuals have been received and reviewed. Each USB flash drive shall be labeled, at a minimum, as follows:
 - 1. Manufacturer name, point of contact, telephone number, facsimile number, and email address as appropriate.
 - 2. Equipment name and/or O&M title spelled out in complete words.
Example: "Operations and Maintenance Manual"
"Horizontal Centrifugal Nonclog Pump"
 - 3. Specifications Section number.
 - 4. Project name.
 - 5. Date and File Name: Example "12-20-25," "01 33 00_01.pdf."

- O. CONTRACTOR shall reprocess any portion of the document that does not view or print to OWNER's satisfaction.
- P. CONTRACTOR is fully responsible for obtaining any and all copyright permissions associated with conversion of this information to electronic format.

PART 2-PRODUCTS

NOT APPLICABLE

PART 3-EXECUTION

NOT APPLICABLE

END OF SECTION

SECTION 01 41 00

REGULATORY REQUIREMENTS

PART 1—GENERAL

1.01 SUMMARY

- A. Work Included:
 - 1. OSHA Requirements.
 - 2. 35 Ill. Adm. Code 1100.
 - 3. Roadway Limits.
 - 4. Permits.
 - 5. Wage Rates.

1.02 OSHA REQUIREMENTS

- A. All work including site safety, equipment, materials, and fabricated items provided under the Contract shall comply with the provisions of the "Occupational Safety and Health Act."

1.03 35 ILL. ADM. CODE 1100

- A. CONTRACTOR shall comply with 35 Ill. Adm. Code 1100 when disposing of clean construction or demolition debris (CCDD) or uncontaminated soil at a CCDD or uncontaminated soil fill operation.

1.04 ROADWAY LIMITS

- A. CONTRACTOR shall comply with roadway weight restrictions including seasonal weight restrictions.

1.05 PERMITS

- A. No permits were obtained by OWNER for this Project. CONTRACTOR shall obtain required permits. Where the requirements of any permit are more restrictive than the Drawings or the Specifications, the permit requirements shall govern.

1.06 WAGE RATES

- A. CONTRACTOR and any subcontractor shall pay all laborers, workers, and mechanics performing work under the Contract not less than the prevailing wage rates adopted by OWNER or determined by the court on review and filed with the Secretary of State in Springfield. A copy of the Schedule of Prevailing Wage Rates is attached hereto.
- B. CONTRACTOR shall keep or cause to be kept a record of employees and wages paid as required by the Prevailing Wage Act (820 ILCS 130/1-12). CONTRACTOR shall also require each subcontractor employed on the project to keep these same records. In accordance with Illinois Public Act 94-0515, CONTRACTOR shall submit certified payroll records on a monthly basis to OWNER, along with a statement affirming that such records are true and accurate, that the wages paid to each worker are not less than the required prevailing rate

and that CONTRACTOR is aware that filing records he or she knows to be false is a Class B misdemeanor.

- C. The certified payroll records shall include for every worker employed on the project the name, address, telephone number, social security number, job classification, hourly wages paid in each pay period, number of hours worked each day, and starting and ending time of work each day.
- D. If at the time this Contract is executed, or if during the term of this Contract, there is excessive unemployment in Illinois as defined in the Employment of Illinois Workers on Public Works Act, 30 ILCS 570, as two consecutive months of unemployment exceeding 5%, CONTRACTOR agrees to employ a work force that is comprised of at least 90% Illinois laborers. An "Illinois laborer" is defined as any person who has resided in Illinois for at least 30 days and intends to become or remain an Illinois resident.
- E. See Wage Rate Forms bound at the end of Division 01.

PART 2-PRODUCTS

NOT APPLICABLE

PART 3-EXECUTION

NOT APPLICABLE

END OF SECTION

SECTION 01 42 00

REFERENCE STANDARDS AND DEFINITIONS

PART 1—GENERAL

1.01 SUMMARY

- A. Work Included:
 - 1. Reference Standards:
 - a. Throughout the Contract Documents, reference is made to codes and standards which establish qualities and types of workmanship and materials, and which establish methods for workmanship and materials, and which establish methods for testing and reporting on the pertinent characteristics.
 - b. Where materials or workmanship are required by these Contract Documents to meet or exceed the specifically named code or standard, it is CONTRACTOR's responsibility to provide materials and workmanship which meet or exceed that specifically named code or standard.
 - c. It is also CONTRACTOR's responsibility, when so required by the Contract Documents, to deliver to ENGINEER all required proof that the material or workmanship, or both, meet or exceed the requirements of the specifically named code or standard.
 - 2. Definitions:
 - a. A substantial amount of specification language constitutes definitions for terms found in other Contract Documents, including the Drawings which must be recognized as diagrammatic in nature and not completely descriptive of requirements indicated thereon.
 - b. Certain terms used in the Contract Documents are defined generally in this section to supplement definitions of the Contract and other general contract documents.
 - c. Definitions and explanations of this section are not necessarily either complete or exclusive, but are general for the Work.
- B. Related Work Described Elsewhere: The specific naming of codes or standards occurs on the Drawings and in other sections of these Specifications.

1.02 QUALITY ASSURANCE

- A. Familiarity with Pertinent Codes and Standards:
 - 1. It is CONTRACTOR's responsibility to verify the requirements of the specifically named codes and standards and to verify that the items procured for use in this Work meet or exceed the specified requirements.
 - 2. When required by individual sections of these Specifications, CONTRACTOR shall obtain a copy of each pertinent code or standard and maintain the copies at the job site during submittals, planning, and progress of the Work until Substantial Completion of the Work is attained.
- B. Overlapping or Conflicting Requirements:
 - 1. Where compliance with two or more industry standards or sets of requirements are specified, and the overlapping of those standards or requirements establishes different or conflicting minimums or levels of quality, the most stringent requirement (which is

generally recognized to be also most costly) is intended and will be enforced, unless more detailed language written directly into Contract Documents clearly indicates that a less stringent requirement is acceptable.

2. Refer all uncertainties to ENGINEER for decision before proceeding.

1.03 REFERENCE STANDARDS

- A. Applicable standards of the construction industry are made a part of the Contract Documents by reference as if copied directly into the Contract Documents, or as if published copies were bound herewith.
- B. Standards referenced directly in the Contract Documents or by governing regulation, have precedence over nonreferenced standards which are recognized in industry for applicability to the Work.
- C. Nonreference standards are hereby defined to have no particular applicability to the Work except as a general measurement of whether the Work complies with standards recognized in the construction industry.
- D. Reference standards and codes listed in these Specifications may include, but are not necessarily limited to, standards or codes published by the following agencies and organizations:

1. AA Aluminum Association
1525 Wilson Boulevard, Arlington, VA 22209
2. AAMA American Architectural Manufacturer's Association
1827 Walden Office Square Suite 550, Schaumburg, IL 60173-4268
3. AASHTO American Association of State Highway & Transportation Officials
444 North Capitol Street NW Suite 249, Washington, DC 20001
4. ACI American Concrete Institute
38800 Country Club Drive, Farmington Hills, MI 48331-3439
5. AI Asphalt Institute
2696 Research Park Drive, Lexington, KY 40511-8480
6. AISC American Institute of Steel Construction
One East Wacker Drive Suite 700, Chicago, IL 60601-1802
7. AISI American Iron and Steel Institute
25 Massachusetts Avenue NW Suite 800, Washington, DC 20001
8. ANSI American National Standards Institute
25 West 43rd Street, New York, NY 10036
9. APA American Plywood Association
7011 South 19th, Tacoma, WA 98466-5333

10. API American Petroleum Institute
1220 L Street NW, Washington, DC 20005-4070
11. ARI Air-Conditioning & Refrigeration Institute
4100 North Fairfax Drive Suite 200, Arlington, VA 22203
12. ASHRAE American Society of Heating, Refrigerating, and Air Conditioning Engineers
1791 Tullie Circle NE, Atlanta, GA 30329
13. ASME American Society of Mechanical Engineers
Two Park Avenue, New York, NY 10016-5990
14. ASSE American Society of Sanitary Engineering
901 Canterbury Suite A, Westlake, OH 44145
15. ASTM ASTM International
100 Barr Harbor Drive, West Conshohocken, PA 19428-2959
16. AWI Architectural Woodwork Institute
46179 Westlake Drive Suite 120, Potomac Falls, VA 20165-5874
17. AWPA American Wood Protection Association
P.O. Box 361784, Birmingham, AL 35236-1784
18. AWS American Welding Society
8669 Doral Boulevard Suite 130, Doral, FL 33166
19. AWWA American Water Works Association
6666 West Quincy Avenue, Denver, CO 80235
20. BHMA Builder's Hardware Manufacturers Association
355 Lexington Avenue 15th floor, New York, NY 10017
21. BIA Brick Industry Association
1850 Centennial Park Drive Suite 301, Reston, VA 20191
22. CRSI Concrete Reinforcing Steel Institute
9333 North Plum Grove Road, Schaumburg, IL 60173
23. EJMA Expansion Joint Manufacturers Association
25 North Broadway, Tarrytown, NY 10591
24. FM FM Global
FM Global Corporate Offices, 270 Central Avenue, Johnston, RI 02919
25. FTI Facing Tile Institute
Box 8880, Canton, OH 44711

- 26. GA Gypsum Association
6525 Belcrest Road Suite 480, Hyattsville, MD 20782

- 27. GANA Glass Association of North America
800 SW Jackson Street Suite 1500, Topeka, KS 66612-1200

- 28. ICC International Code Council
500 New Jersey Avenue NW 6th Floor, Washington, DC 20001

- 29. IES Illuminating Engineering Society
120 Wall Street, Floor 17, New York, NY 10005-4001

- 30. MIL Military Specifications
Naval Publications and Forms Center
5801 Tabor Avenue, Philadelphia, PA 19120

- 31. NAAMM National Association of Architectural Metal Manufacturers
800 Roosevelt Road Building C Suite 312, Glen Ellyn, IL 60137

- 32. NCMA National Concrete Masonry Association
13750 Sunrise Valley Drive, Herndon, VA 20171-4662

- 33. NECA NECA
National Electrical Contractors Association
3 Bethesda Metro Center Suite 1100, Bethesda, MD 20814

- 34. NEMA National Electrical Manufacturers Association
1300 North 17th Street Suite 1752, Rosslyn, VA 22209

- 35. NFPA National Fire Protection Association
1 Batterymarch Park, Quincy, MA 02169-7471

- 36. NIST National Institute of Standards and Technology
(U.S. Department of Commerce), 100 Bureau Drive, Stop 1070
Gaithersburg, MD 20899-1070

- 37. NRCA National Roofing Contractors Association
10255 West Higgins Road Suite 600, Rosemont, IL 60018-5607

- 38. NSF National Sanitation Foundation International
P.O. Box 130140, 789 North Dixboro Road, Ann Arbor, MI 48113-0140

- 39. OSHA Occupational Safety & Health Administration
200 Constitution Avenue NW, Washington, DC 20210

- 40. PCA Portland Cement Association
5420 Old Orchard Road, Skokie, IL 60077

- 41. PCI Prestressed Concrete Institute
200 West Adams Street Suite 2100, Chicago, IL 60606
- 42. SAE Society of Automotive Engineers
SAE World Headquarters
400 Commonwealth Drive, Warrendale, PA 15096-0001
- 43. SDI Steel Deck Institute
P.O. Box 25, Fox River Grove, IL 60021
- 44. SDI Steel Door Institute
30200 Detroit Road, Westlake, OH 44145-1987
- 45. SIGMA Sealed Insulating Glass Manufacturers Assoc.
401 North Michigan Avenue Suite 2400, Chicago, IL 60611
- 46. SJI Steel Joist Institute
234 Cheves Street, Florence, SC 29501
- 47. SMACNA Sheet Metal and Air Conditioning
Contractor's National Association
4201 Lafayette Center Drive, Chantilly, VA 20151-1219
- 48. SSPC Society for Protective Coatings
40 24th Street 6th Floor, Pittsburgh, PA 15222-4656
- 49. TCA Tile Council of America
100 Clemson Research Boulevard, Anderson, SC 29625
- 50. UL Underwriters Laboratories
333 Pfingston Road; Northbrook, IL 60062

1.04 SUBMITTALS

- A. For OWNER's records, CONTRACTOR shall submit copies of permits, licenses, certifications, inspection reports, and similar documents, correspondence and records established in conjunction with compliance with standards and regulations bearing upon performance of the Work.

1.05 DEFINITIONS

- A. Indicated:
 1. The term "indicated" is a cross-reference to details, notes, or schedules on the Drawings, to other paragraphs or schedules in the Specifications and to similar means of recording requirements in the Contract Documents.
 2. Where terms such as "shown," "noted," "scheduled," and "specified" are used in lieu of "indicated," it is for the purpose of helping the reader locate cross-reference, and no limitation is intended except as specifically noted.

- B. Approve (or Words of Similar Nature):
1. Where used in conjunction with ENGINEER's response to submittals, requests, applications, inquiries, reports, and claims by CONTRACTOR, the meaning of the term "approve" will be held to the limitation of ENGINEER's responsibilities and duties as specified in Paragraph 1.02.B of the General Conditions.
 2. In no case will "approval" by ENGINEER be interpreted as a release of CONTRACTOR from responsibility to fulfill requirements of the Contract Documents.
- C. Minimum Requirements:
1. Indicated requirements are for a specific minimum acceptable level of quality or quantity, as recognized in the industry.
 2. Actual work must comply with (or within specified tolerances) or exceed minimums.
 3. CONTRACTOR shall refer uncertainties to ENGINEER before proceeding.
- D. Abbreviations: Abbreviations, where not defined in the Contract Documents, will be interpreted to mean the normal construction industry terminology.

PART 2-PRODUCTS

NOT APPLICABLE

PART 3-EXECUTION

NOT APPLICABLE

END OF SECTION

SECTION 01 45 00

QUALITY CONTROL

PART 1–GENERAL

1.01 SUMMARY

- A. Work Includes:
 - 1. Quality Assurance–Control of Installation.
 - 2. Tolerances.
 - 3. Manufacturers' Field Services and Reports.

1.02 QUALITY ASSURANCE–CONTROL OF INSTALLATION

- A. CONTRACTOR shall monitor quality control over suppliers, manufacturers, products, services, site conditions, and workmanship to produce Work of specified quality.
- B. CONTRACTOR shall comply with manufacturers' instructions, including each step in sequence.
- C. Should manufacturers' instructions conflict with Contract Documents, CONTRACTOR shall request clarification from ENGINEER before proceeding.
- D. CONTRACTOR shall comply with specified standards as minimum quality for the Work except where more stringent tolerances, codes, or specified requirements indicate higher standards or more precise workmanship.
- E. Work shall be performed by persons qualified to produce workmanship of specified quality.
- F. CONTRACTOR shall secure products in place with positive anchorage devices designed and sized to withstand stresses, vibration, physical distortion, or disfigurement.

1.03 TOLERANCES

- A. CONTRACTOR shall monitor tolerance control of installed products to produce acceptable work and shall not permit tolerances to accumulate.
- B. CONTRACTOR shall comply with manufacturers' tolerances. Should manufacturers' tolerances conflict with Contract Documents, CONTRACTOR shall request clarification from ENGINEER before proceeding.
- C. CONTRACTOR shall adjust products to appropriate dimensions; position before securing products in place.

1.04 MANUFACTURERS' FIELD SERVICES AND REPORTS

- A. When specified in individual specification sections or when requested by ENGINEER, CONTRACTOR shall require material or product suppliers or manufacturers to provide qualified staff personnel to observe site conditions, conditions of surfaces and installation, and quality of workmanship.

- B. CONTRACTOR shall submit qualifications of observer to ENGINEER 30 days in advance of required observations.
- C. CONTRACTOR shall report observations and site decisions or instructions given to applicators or installers that are supplemental or contrary to manufacturers' written instructions.
- D. CONTRACTOR shall submit report in duplicate within 30 days of observation to ENGINEER for information.

PART 2-PRODUCTS

NOT APPLICABLE

PART 3-EXECUTION

NOT APPLICABLE

END OF SECTION

SECTION 01 50 00

TEMPORARY FACILITIES

PART 1–GENERAL

1.01 SUMMARY

- A. Work Included:
 - 1. Temporary Utilities.
 - 2. Temporary Support Facilities.
 - 3. Removal of Temporary Facilities.
- B. CONTRACTOR shall arrange for and provide temporary facilities as required for proper and expeditious prosecution of the Work.
- C. CONTRACTOR shall pay all costs, except as otherwise specified, until final acceptance of the Work unless OWNER makes arrangements for use of completed portions of the Work after substantial completion in accordance with the provisions of the Contract Documents.
- D. CONTRACTOR shall make all temporary connections to utilities and services in locations acceptable to OWNER and local authorities having appropriate jurisdiction.
 - 1. Furnish all necessary labor and materials.
 - 2. Make all installations in a manner subject to the acceptance of such authorities and OWNER.
 - 3. Maintain such connections.
 - 4. Remove temporary installation and connection when no longer required.
 - 5. Restore services and sources of supply to proper operating conditions.

1.02 TEMPORARY UTILITIES

- A. Temporary Toilets: CONTRACTOR shall provide and maintain sanitary temporary chemical toilets located where approved by OWNER and in sufficient number required for the work force employed by CONTRACTOR.
- B. Temporary Electrical Services:
 - 1. Existing outlets and wiring shall not be used for motors larger than fractional HP or for welding equipment. Circuits for larger motors and welding equipment may be provided with special circuits to mains of electrical panels at the expense of those trades requiring them, provided that written permission is obtained from OWNER and ENGINEER.
 - 2. Any temporary electrical services required during power outages shall be obtained and paid for by CONTRACTOR.
 - 3. All temporary lighting required for construction as well as OWNER's full use of the entire facility throughout construction shall be provided by CONTRACTOR.
 - 4. No permanent electrical equipment or wiring shall be used without express written permission of OWNER. Such approval, if given, shall not affect guarantee period.
- C. Weather Protection and Temporary Heat: CONTRACTOR shall provide weather protection to protect the Work from damage because of freezing, rain, snow, and other inclement weather.

- D. Temporary Water: CONTRACTOR shall supply its own water during construction. CONTRACTOR shall also provide its own piping, valves, and appurtenances for its requirements. Connection to the existing water system shall be coordinated with OWNER and shall meet all code requirements including disinfection and backflow prevention.
- E. Temporary Fire Protection: CONTRACTOR and Subcontractor(s) who maintain or provide an enclosed shed or trailer shall provide and maintain in operating order in each shed or trailer a minimum of one fire extinguisher. More extinguishers shall be provided as necessary. Fire extinguishers shall be minimum dry chemical, nonfreezing-type, UL rating 2A-30BC, with 10-pound capacity for Class A, B, and C fires.
- F. CONTRACTOR's and Subcontractor(s)' personnel shall refrain from smoking during excavation, laying pipe, backfilling, and other work at the Site which may involve potential contact with explosive vapors or gasoline products.

1.03 TEMPORARY SUPPORT FACILITIES

- A. CONTRACTOR shall provide whatever facilities and services needed to properly support the primary construction process and meet compliance requirements and governing regulations.
- B. CONTRACTOR shall not use permanent facilities, except as otherwise indicated, unless authorized by OWNER.

1.04 REMOVAL OF TEMPORARY FACILITIES

- A. Remove temporary materials, equipment, services, and construction as soon as practicable but no later than just prior to substantial completion inspection.
- B. Clean and repair damage caused by installation or use of temporary facilities and restore existing facilities used during construction to specified, or to original, condition.

PART 2-PRODUCTS

NOT APPLICABLE

PART 3-EXECUTION

NOT APPLICABLE

END OF SECTION

SECTION 01 52 13
FIELD OFFICES AND SHEDS

PART 1–GENERAL

1.01 SUMMARY

- A. Work Included:
 - 1. Materials, Equipment, and Furnishings.
 - 2. Construction.
 - 3. Environmental Control.
 - 4. CONTRACTOR Office and Facilities.
 - 5. Storage Areas and Sheds.
 - 6. Preparation.
 - 7. Installation.
 - 8. Maintenance and Cleaning.
 - 9. Removal.

PART 2–PRODUCTS

2.01 MATERIALS, EQUIPMENT, AND FURNISHINGS

- A. Materials, equipment, and furnishings shall be serviceable, new or used, and adequate for required purpose.

2.02 CONSTRUCTION

- A. Portable or mobile buildings or buildings shall be constructed with floors raised above ground, securely fixed to foundations, with steps and landings at entrance doors.
- B. CONTRACTOR shall provide structurally sound, secure, weathertight enclosures for office and storage spaces.
- C. Temperature transmission resistance of floors, walls, and ceilings shall be compatible with occupancy and storage requirements.
- D. Exterior materials shall be weather resistant.
- E. Provide appropriate type fire extinguisher at each office and each storage area.
- F. Interior materials in storage sheds shall be as required to provide specified conditions for storage of products.

2.03 ENVIRONMENTAL CONTROL

- A. Heating, cooling, and ventilating for offices shall consist of automatic equipment to maintain comfort conditions; 70°F heating and 78°F cooling.

2.04 CONTRACTOR OFFICE AND FACILITIES

- A. CONTRACTOR shall provide facilities to meet CONTRACTOR's needs and to provide space for Project meetings.
- B. Provide telephone as required for CONTRACTOR's needs.

2.05 STORAGE AREAS AND SHEDS

- A. Provide storage areas and sheds of size to meet storage requirements for products of individual sections, allowing for access and orderly provision for maintenance and for observation of products to meet requirements of Section 01 60 00–Materials and Equipment.

PART 3–EXECUTION

3.01 PREPARATION

- A. CONTRACTOR shall fill and grade sites for temporary structures to provide drainage away from buildings.

3.02 INSTALLATION

- A. CONTRACTOR shall install office spaces ready for occupancy 15 days after date fixed in Notice to Proceed or as agreed upon by ENGINEER.
- B. Provide two hard surfaced parking spaces for use by ENGINEER, connected to office by hard surfaced walk.

3.03 MAINTENANCE AND CLEANING

- A. CONTRACTOR shall maintain approach walks free of mud, water, and snow.

3.04 REMOVAL

- A. Upon final acceptance and completion of the Work, CONTRACTOR shall remove field offices, foundations, utility services, and debris and shall restore areas.

END OF SECTION

SECTION 01 57 00
TEMPORARY CONTROLS

PART 1–GENERAL

1.01 SUMMARY

- A. Work Included:
 - 1. Dust Control.
 - 2. Water, Erosion, and Sediment Control.
 - 3. Noise Control.
 - 4. Traffic Control.
 - 5. Site Security.
 - 6. Daily Cleanup.

PART 2–PRODUCTS

NOT APPLICABLE

PART 3–EXECUTION

3.01 DUST CONTROL

- A. CONTRACTOR shall execute the Work by methods to minimize raising dust from construction operations.
- B. CONTRACTOR shall provide positive means to prevent airborne dust from dispersing into atmosphere.
- C. CONTRACTOR shall provide partitions, enclosures, etc., within buildings as necessary to confine dust and protect adjacent areas.

3.02 WATER, EROSION, AND SEDIMENT CONTROL

- A. CONTRACTOR shall grade site to drain and shall maintain excavations free of water. Provide, operate, and maintain pumping equipment.
- B. CONTRACTOR shall protect Site from puddling or running water.
- C. CONTRACTOR shall provide erosion control measures as necessary to control discharge of sediment laden water to surface waters and wetlands.
- D. Except as provided for in the document, overland discharge of water from dewatering operations shall not be allowed. Depending on water quality, such water shall either be piped directly to the surface water or shall be directed to sedimentation basins or other such structures or features prior to discharge to surface waters so as not to cause damage to existing ground and improvements, erosion, or deposition in the discharge area.

- E. CONTRACTOR shall use jute or synthetic netting, silt fences, straw bales, dikes, channels, and other applicable measures to prevent erosion of soils disturbed by its construction operation.
- F. Restoration of the Site shall proceed concurrently with the construction operation. See Drawings and Specifications for erosion control measures in addition to that which may be required above.
- G. Erosion control measures shall comply with the current edition of the Illinois Urban Manual.

3.03 NOISE CONTROL

- A. Provide methods, means, and facilities to minimize noise produced by construction operations.

3.04 TRAFFIC CONTROL

- A. CONTRACTOR shall be responsible for providing all signs, barricades, flagmen, and other traffic control devices in the construction zone.
- B. Conduct operations with minimum interference to roadways.
- C. Maintain one-way traffic on streets at all times.
- D. All traffic control measures shall meet the requirements of Illinois Manual on Uniform Traffic Control Devices for Streets and Highways, Latest Edition, and the Standard Specifications for Traffic control Items, Latest Edition.
- E. Do not close or obstruct roadways without approval of OWNER.

3.05 SITE SECURITY

- A. CONTRACTOR shall have the sole responsibility of safeguarding the Site perimeter to prevent unauthorized entry to the Site throughout the duration of the Project. CONTRACTOR shall at all times provide such permanent and temporary fencing or barricades or other measures as may be necessary to restrict unauthorized entry to its construction area including construction in public rights-of-way or easements. Site security measures shall include safeguards against attractive nuisance hazards as a result of construction activity.
- B. CONTRACTOR shall at all times be responsible for the security of the Work including materials and equipment. OWNER will not take any responsibility for missing or damaged equipment, tools, or personal belongings. CONTRACTOR shall have the sole responsibility of safeguarding the Work and the Site throughout the duration of the Project.

3.06 DAILY CLEANUP

- A. CONTRACTOR shall clean up the Site and remove all rubbish on a daily basis.

- B. CONTRACTOR shall clean up public streets and highways and remove any dirt, mud, or other materials due to project traffic on daily basis and shall comply with all local and state ordinances and permit requirements.

END OF SECTION

SECTION 01 60 00

MATERIALS AND EQUIPMENT

PART 1—GENERAL

1.01 SUMMARY

- A. Work Included: CONTRACTOR shall be responsible for the delivery, handling, storage and protection of all material and equipment required to complete the Work as specified herein.
- B. Related Sections and Divisions: Specific requirements for the handling and storage of material and equipment are described in other sections of these Specifications.

1.02 PRODUCTS

- A. Components required to be supplied in quantity within a Specification section shall be the same, and shall be interchangeable.
- B. CONTRACTOR shall not use materials and equipment removed from existing construction, except as specifically required, or allowed, by the Contract Documents.
- C. When any construction deviations from the Drawings and/or Specifications necessary to accommodate equipment supplied by CONTRACTOR, result in additional costs to CONTRACTOR or other contractors, such additional costs shall be borne by CONTRACTOR. CONTRACTOR shall also pay any additional costs necessary for revisions of Drawings and/or Specifications by ENGINEER.
- D. Each major component of equipment shall bear a nameplate giving the name and address of the manufacturer and the catalogue number or designation.

1.03 TRANSPORTATION AND HANDLING

- A. Materials, products and equipment shall be properly containerized, packaged, boxed, and protected to prevent damage during transportation and handling.
- B. CONTRACTOR shall not overload any portion of the structure in the transporting or storage of materials.
- C. CONTRACTOR shall not damage other construction by careless transportation, handling, spillage, staining or impact of materials.
- D. CONTRACTOR shall provide equipment and personnel to handle products, including those provided by OWNER, by methods to prevent soiling and damage.
- E. CONTRACTOR shall provide additional protection during handling to prevent marring and otherwise damaging products, packaging, and surrounding surfaces.
- F. CONTRACTOR shall handle product by methods to avoid bending or overstressing. Lift large and heavy components only at designated lift points.

1.04 DELIVERY AND RECEIVING

- A. CONTRACTOR shall arrange deliveries of products in accordance with the Progress Schedule, allowing time for observation prior to installation.
- B. CONTRACTOR shall coordinate deliveries to avoid conflict with the Work and conditions at the Site; work activities of other contractors or OWNER; limitations on storage space; availability of personnel and handling equipment and OWNER's use of premises.
- C. CONTRACTOR shall deliver products in undamaged, dry condition, in original unopened containers or packaging with identifying labels intact and legible.
- D. CONTRACTOR shall clearly mark partial deliveries of component parts of equipment to identify equipment and contents to permit easy accumulation of parts and to facilitate assembly.
- E. Immediately on delivery, CONTRACTOR shall inspect shipment to review that:
 - 1. Product complies with requirements of Contract Documents and reviewed submittals.
 - 2. Quantities are correct.
 - 3. Accessories and installation hardware are correct.
 - 4. Containers and packages are intact and labels legible.
 - 5. Products are protected and undamaged.

1.05 STORAGE AND PROTECTION

- A. General:
 - 1. CONTRACTOR shall store products, immediately on delivery, in accordance with manufacturer's instructions, with all seals and labels intact and legible.
 - 2. Any additional off-site space required shall be arranged by CONTRACTOR.
 - 3. CONTRACTOR shall allocate the available storage areas and coordinate their use by the trades on the job.
 - 4. CONTRACTOR shall arrange storage in a manner to provide access for maintenance of stored items and for observation.
- B. In enclosed storage, CONTRACTOR shall:
 - 1. Provide suitable temporary weather tight storage facilities as may be required for materials that will be damaged by storage in the open.
 - 2. Maintain temperature and humidity within ranges stated in manufacturer's instructions.
 - 3. Provide ventilation for sensitive products as required by manufacturer's instructions.
 - 4. Store unpacked and loose products on shelves, in bins, or in neat groups of like items.
 - 5. Store solid materials such as insulation, tile, mechanical and electrical equipment, fittings, and fixtures under shelter, in original packages, away from dampness and other hazards.
 - 6. Store liquid materials away from fire or intense heat and protect from freezing.
- C. At exterior storage, CONTRACTOR shall:
 - 1. Store unit materials such as concrete block, brick, steel, pipe, conduit, door frames, and lumber off ground, out of reach of dirt, water, mud and splashing.
 - 2. Store tools or equipment that carry dirt outside.
 - 3. Store large equipment so as not to damage the Work or present a fire hazard.

4. Cover products subject to discoloration or deterioration from exposure to the elements, with impervious sheet material and provide ventilation to avoid condensation.
5. Completely cover and protect any equipment or material which is prime coated or finish painted with secured plastic or cloth tarps. Store out of reach of dirt, water, mud and splashing.
6. Store loose granular materials on clean, solid surfaces such as pavement, or on rigid sheet materials, to prevent mixing with foreign matter.
7. Provide surface drainage to prevent erosion and ponding of water.
8. Prevent mixing of refuse or chemically injurious materials or liquids.
9. Cover aggregates such as sand and gravel in cold wet weather.
10. Remove all traces of piled bulk materials at completion of work and return site to original or indicated condition.

1.06 MAINTENANCE OF STORAGE

- A. CONTRACTOR shall periodically inspect stored products on a scheduled basis.
- B. CONTRACTOR shall verify that storage facilities comply with manufacturer's product storage requirements, and verify that manufacturer required environmental conditions are maintained continually.
- C. CONTRACTOR shall verify that surfaces of products exposed to the elements are not adversely affected and that any weathering of finishes is acceptable under requirements of Contract Documents.
- D. CONTRACTOR shall perform scheduled maintenance of equipment in storage as recommended by the manufacturer. A record of the maintenance shall be kept and turned over to ENGINEER when the equipment is installed.

1.07 INSTALLATION REQUIREMENTS

- A. Manufactured articles, materials, and equipment shall be applied, installed, connected, erected, used, cleaned, and conditioned as directed by the respective manufacturers, unless otherwise specified.
- B. After installation, CONTRACTOR shall protect all materials and equipment against weather, dust, moisture, and mechanical damage.
- C. CONTRACTOR shall be responsible for all damages that occur in connection with the care and protection of all materials and equipment until completion and final acceptance of the Work by OWNER. Damaged material and equipment shall be immediately removed from the Site.

1.08 EQUIPMENT WARRANTIES

- A. Warranties shall be nonprorated, include all parts and labor, and be in written form. Warranties shall specifically exclude buyer's indemnification language. Warranty language shall not eliminate manufacturer's responsibility for sizing of the equipment. During warranty period, manufacturer shall be responsible for any travel expenses, outside contractor fees, and rental equipment fees associated with providing warranty service. Manufacturer shall pay expenses incurred for repairs and parts replacement not made by manufacturer if

manufacturer's response is not within 72 hours of notification by OWNER. Warranty language shall be provided with the shop drawings.

1.09 CONCRETE EQUIPMENT BASE

- A. Cast-in-place concrete equipment bases shall be provided for all new and relocated equipment including electrical control panels, motor control centers, switchgear, etc. Concrete equipment bases shall be provided by CONTRACTOR except where specifically noted to be provided by others. Bases shall be 3 1/2-inch minimum height and shall be a minimum of 3 inches larger than equipment being supported. Grouting of equipment bases shall be as recommended by equipment manufacturer.
- B. Concrete and grout shall meet applicable sections of the Specifications.
- C. Provide all anchor bolts, metal shapes and templates to be cast in concrete or used to form concrete for support of equipment.

PART 2-PRODUCTS

NOT APPLICABLE

PART 3-EXECUTION

NOT APPLICABLE

END OF SECTION

SECTION 01 73 29

CUTTING, PATCHING, AND ALTERATIONS

PART 1—GENERAL

1.01 SUMMARY

- A. Work Included: CONTRACTOR shall be responsible for all cutting, fitting, patching, and other alterations required to complete the Work as specified herein or to:
 - 1. Make its several parts fit together properly.
 - 2. Uncover portions of the Work to install improperly sequenced Work.
 - 3. Remove and replace defective Work.
 - 4. Remove and replace Work not conforming to requirements of the Contract Documents.
 - 5. Remove samples of installed Work as specified for testing.
 - 6. Provide penetrations of surfaces for installation of piping and electrical conduit.
 - 7. Rehabilitate existing spaces.

1.02 REFERENCES

- A. ANSI A10 Safety Requirements for Construction and Demolition.

1.03 QUALITY ASSURANCE

- A. CONTRACTOR shall perform all cutting, patching, and alterations in strict accordance with pertinent requirements of these Specifications.
- B. Except as modified by governing codes, CONTRACTOR shall comply with the applicable provision and recommendations of ANSI A10.

1.04 SUBMITTALS

- A. CONTRACTOR shall submit a written request to OWNER well in advance of executing any cutting or alteration which affects the following:
 - 1. Work of OWNER or any separate contractor.
 - 2. Structural value or integrity of any element of the Project.
 - 3. Integrity or effectiveness of weather-exposed or moisture-resistant elements or systems.
 - 4. Efficiency, operational life, maintenance, or safety of operational elements.
 - 5. Visual qualities of sight-exposed elements.
- B. The request shall include:
 - 1. Description of affected work.
 - 2. The necessity for cutting, patching, or alteration.
 - 3. Effect on work of OWNER, any separate contractor, or on the structural or weather-proof integrity of the Project.
 - 4. Description of proposed work to include:
 - a. Scope of cutting, patching, or alteration.
 - b. Trades who will execute the Work.
 - c. Products proposed to be used.
 - d. Extent of refinishing to be done.

5. Alternatives to cutting and patching.
 6. Written permission of any separate contractor whose work will be affected.
- C. Submit written notice to OWNER designating the date and the time the Work will be uncovered or executed.

1.05 SCHEDULING AND COORDINATION

- A. All work under this section shall be coordinated with OWNER's work forces and those of other contractors and shall be accomplished at times acceptable to OWNER.
- B. Before starting any work relating to existing utilities (electrical, sewer, water, heat, gas, fire lines, etc.) that will temporarily discontinue or disrupt service to the existing building, notify ENGINEER and OWNER 72 hours in advance and obtain OWNER's approval before proceeding with this phase of the Work. Temporary facilities, if required, shall be in place prior to disruption of service.

PART 2-PRODUCTS

2.01 NEW MATERIALS

- A. For replacement of work removed, CONTRACTOR shall use materials which comply with the pertinent sections of these Specifications.
- B. All new materials for patching and extending work shall match existing products and work.
- C. CONTRACTOR shall determine type and quality of existing products by inspection and any necessary testing and workmanship by use of existing as the standard.

2.02 UNSALVAGEABLE MATERIALS

- A. Materials or items demolished and not designated to become the property of OWNER or not designated to be reinstalled shall become the property of CONTRACTOR and shall be removed from the site and legally and properly disposed of by CONTRACTOR.
- B. Materials shall be removed by CONTRACTOR in a manner that will avoid damage to materials or equipment to remain.

PART 3-EXECUTION

3.01 INSPECTION

- A. CONTRACTOR shall inspect existing conditions including elements subject to movement or damage during cutting, patching, and other alterations.
- B. After uncovering the Work, CONTRACTOR shall inspect conditions affecting installation of new products or performance of new work.
- C. CONTRACTOR shall report unsatisfactory or questionable conditions to ENGINEER in writing.

- D. CONTRACTOR shall not proceed with work until unsatisfactory or questionable conditions are resolved.
- E. Beginning of cutting, patching, and alterations work means acceptance of existing conditions by CONTRACTOR.

3.02 PREPARATION AND PROTECTION

- A. CONTRACTOR shall provide temporary bracing, shoring, needling, and support of the structure during alterations work as necessary to prevent collapse, settling, or deflection and to protect persons and property from injury or damage.
- B. Temporary supports must adequately carry all existing and imposed load.
- C. CONTRACTOR shall provide and maintain temporary protection of surface finishes, equipment, and adjacent work designated to remain where demolition, removal, and new work is being done, connections are being made, materials are being handled, or equipment is being removed.
- D. CONTRACTOR shall provide temporary partitions or barriers to contain all dust, dirt, and debris from entering into finished areas or areas where OWNER is operating, storing, or manufacturing products.
- E. CONTRACTOR shall provide adequate fire protection in accordance with local Fire Department requirements.
- F. CONTRACTOR shall provide waterproofing, weather protection, heat, and other facilities for that portion of the Work which may be exposed by cutting and patching, demolition, or other alterations.
- G. CONTRACTOR shall cut, move, or remove items as necessary for access to alterations and renovations work and replace and restore at completion of the Work.
- H. CONTRACTOR shall prepare surfaces and remove surface finishes to provide for proper installation of new work and new finishes.
- I. CONTRACTOR shall be responsible for any damage to the existing structure or its contents directly or indirectly by its crews or those of its subcontractors.

3.03 PERFORMANCE

- A. CONTRACTOR shall accomplish all work of cutting, removal, demolition, patching, or other alterations using only persons skilled in the appropriate trade.
- B. CONTRACTOR shall execute the Work in a careful and orderly manner with the least possible disturbance to the public and to the occupants of the building.
- C. CONTRACTOR shall execute cutting and demolition by methods which will prevent damage to other work and will provide proper surfaces to receive installation of repairs.

- D. CONTRACTOR shall execute fitting and adjustment of products to provide a finished installation to comply with specified products, functions, tolerances, and finishes.
- E. CONTRACTOR shall fit work airtight to pipes, sleeves, ducts, conduit, and other penetrations through surfaces.
- F. CONTRACTOR shall thoroughly clean and prepare all surfaces to receive new finish or covering to completely remove all dirt, dust, grease, oil, paint, loose materials, and soil.
- G. CONTRACTOR shall refinish entire surface as necessary to provide an even finish to match adjacent finishes:
 - 1. For continuous surfaces, refinish to nearest intersection.
 - 2. For an assembly, refinish entire unit.

3.04 DEMOLITION, CUTTING, AND REMOVAL

- A. Cutting and removal of construction shall be performed by CONTRACTOR so as not to cut or remove more than is necessary and so as not to damage adjacent work.
- B. CONTRACTOR shall cut out embedded anchorages and attachment items as required to properly provide for patching and repair of the respective finishes.
- C. CONTRACTOR shall not cut structural work in a manner resulting in a reduction of load-carrying capacity or load/deflection ratio.
- D. CONTRACTOR shall not cut operational elements and safety components in a manner resulting in decreased performance, shortened useful life, or increased maintenance.
- E. CONTRACTOR shall not cut work exposed to view (exterior or interior) in a manner resulting in noticeable reduction of visual qualities as determined by OWNER.
- F. Construction that is to remain which is loosened, cracked, or otherwise damaged or defaced as a result of careless cutting or demolition and is unsuitable for use intended shall be removed and replaced at no additional cost to OWNER.
- G. CONTRACTOR shall clean demolished areas and remove debris, waste, and rubbish from the building at the conclusion of each day's work.
- H. CONTRACTOR shall not let piled waste material endanger the structure.

3.05 PATCHING, EXTENDING, AND MATCHING

- A. Patching work shall conform to the standards of the Specifications where applicable, and where not specified, work shall conform to the highest standards of the applicable trade.
- B. CONTRACTOR shall patch construction to match adjacent work unless noted otherwise.
- C. Patching or restoration shall be carried to natural breaks (e.g., corners) wherever possible.
- D. CONTRACTOR shall provide adequate support to substrate for patching finishes.

- E. Transitions:
1. Where new work abuts or finishes flush with existing work, CONTRACTOR shall make the transition as smooth as possible.
 2. Patched work shall match adjacent work in texture and appearance so as to make the patch or transition invisible to the eye at a distance of 3 feet.
 3. Where masonry, tile, plaster, metal, or other finished surface is cut in such a way that a smooth transition is not possible, CONTRACTOR shall terminate the existing surface in a neat fashion along a straight line at a natural line of division and provide trim appropriate to the finished surface.
 4. In case of extreme level changes (3 inches or more), review condition with ENGINEER prior to making transition.
 5. CONTRACTOR shall restore existing work that is damaged during patching operations to a condition equal to its construction at the time of the start of the Work.

3.06 UNANTICIPATED MECHANICAL AND ELECTRICAL WORK EXPOSED

- A. Where unanticipated mechanical piping or electrical conduit is exposed removal or rerouting shall be accomplished by CONTRACTOR as applicable.
1. Rerouted piping shall be located and shall be connected to maintain all functions in proper operations.
 2. Abandoned piping may be left in place where it is buried in floors or walls, providing that it is completely disconnected from its source.
 3. There shall be no "dead end" gas, water, sewer, or vent piping existing in the completed work.
 4. Unless otherwise shown, abandoned piping, ductwork, conduit, or other mechanical or electrical items in chases, vertical enclosures, or concealed above ceilings shall be completely removed.
- B. Removals, capping, or otherwise terminating services which are abandoned shall be accomplished without additional cost to OWNER.
- C. Relocation of services resulting from unanticipated conflicts of new and existing work in concealed spaces shall be paid for in accordance with the Contract Documents.

END OF SECTION

SECTION 01 77 00
CONTRACT CLOSEOUT

PART 1—GENERAL

1.01 SUMMARY

- A. Work Included:
 - 1. Closeout Procedures.
 - 2. Final Cleaning.
 - 3. Adjusting.
 - 4. Project Record Documents.
 - 5. Warranties.

1.02 CLOSEOUT PROCEDURES

- A. CONTRACTOR shall provide submittals to ENGINEER that are required by governing or other authorities.
- B. CONTRACTOR shall comply with the Contract Documents and complete the following before requesting ENGINEER's observation of the Work or designated portion thereof for substantial completion.
 - 1. Submit executed warranties, workmanship bonds, maintenance agreements, inspection certificates, and similar required documentation for specific units of Work, enabling OWNER's unrestricted occupancy and use.
 - 2. Submit record documentation, maintenance manuals, tools, spare parts, keys, and similar operational items.
 - 3. Submit consent of surety (if surety required in Contract).
 - 4. Complete final cleaning, touch-up work of marred surfaces, and remove temporary facilities and tools.

1.03 FINAL CLEANING

- A. It is CONTRACTOR's responsibility to completely clean up the inside and outside of all buildings and the construction site at the completion of the Work.
- B. CONTRACTOR shall clean areas of the building in which painting and finishing work is to be performed just prior to the start of this work and maintain these areas in satisfactory condition for painting and finishing. This cleaning includes:
 - 1. Removal of trash and rubbish from these areas.
 - 2. Broom cleaning of floors.
 - 3. Removal of any plaster, mortar, dust, and other extraneous materials from finish surfaces, including but not limited to exposed structural steel, miscellaneous metal, masonry, concrete, mechanical equipment, piping, and electrical equipment.
- C. In addition to the cleaning specified above and the more specific cleaning that may be required in various technical sections of the Specifications, CONTRACTOR shall prepare the Project for occupancy by a thorough cleaning throughout, which shall include the following:

1. Clean interior and exterior glass surfaces exposed to view; remove temporary labels, stains and foreign substances, polish transparent and glossy surfaces, vacuum carpeted and soft surfaces.
2. Clean equipment and fixtures to a sanitary condition with cleaning materials appropriate to the surface and material being cleaned.
3. Replace filters of operating equipment.
4. Clean debris from roofs, gutters, downspouts, and drainage systems.
5. Clean site; sweep paved areas, rake clean landscaped surfaces.
6. Remove waste and surplus materials, rubbish, and construction facilities from the Site.

1.04 ADJUSTING

- A. CONTRACTOR shall adjust operating products and equipment to provide smooth and unhindered operation.

1.05 PROJECT RECORD DOCUMENTS

- A. CONTRACTOR shall maintain on Site one set of the following record documents to record actual revisions to the Work:
 1. Drawings.
 2. Specifications.
 3. Addenda.
 4. Change orders and other modifications to the Contract.
 5. Reviewed shop drawings, product data, and samples.
 6. Manufacturer's instruction for assembly, installation, and adjusting.
- B. CONTRACTOR shall make entries that are complete and accurate, enabling future reference by OWNER.
- C. CONTRACTOR shall store record documents separate from documents used for construction.
- D. CONTRACTOR shall record information concurrent with construction progress.
- E. Specifications: CONTRACTOR shall legibly mark and record at each Product section description of actual products installed, including the following:
 1. Manufacturer's name and product model and number.
 2. Product substitutions or alternates utilized.
 3. Changes made by addenda and modifications.
- F. Record Drawings: CONTRACTOR shall legibly mark each item to record actual construction including:
 1. Measured depths of foundations in relation to finish floor datum.
 2. Measured horizontal and vertical locations of underground utilities and appurtenances referenced to permanent surface improvements.
 3. Measured locations of internal utilities and appurtenances concealed in construction referenced to visible and accessible features of the Work.
 4. Field changes of dimension and detail.
 5. Details not on original Contract Drawings.

1.06 WARRANTIES

- A. CONTRACTOR shall provide warranties beyond project one-year warranty as required by technical sections.
- B. Submit warranty information as follows:
 - 1. Provide original copies bearing authorized signatures.
 - 2. Execute and assemble transferable warranty documents from Subcontractors, suppliers, and manufacturers, and provide Table of Contents and assemble in three-ring binder with durable cover.
 - 3. Submit with request for certificate of Substantial Completion.
 - 4. For items of work delayed beyond date of Substantial Completion, provide updated submittal within 10 days after acceptance listing date of acceptance as start of warranty period.

PART 2-PRODUCTS

NOT APPLICABLE

PART 3-EXECUTION

NOT APPLICABLE

END OF SECTION

SECTION 01 91 00
STARTING OF SYSTEMS

PART 1—GENERAL

1.01 SUMMARY

- A. Work Included:
 - 1. General.
 - 2. Equipment and System Installation.
 - 3. Starting Equipment and Systems.
 - 4. Demonstration, Instructions, and Operator Training.
 - 5. Start-Up and Testing.
 - 6. Equipment Systems Requiring Certification of Proper Installation.
- B. CONTRACTOR shall perform the Work described in the following subsections.

1.02 GENERAL

- A. The number of days for manufacturer's services stated in the Specifications shall be considered as the minimum number of days. Should additional time be required for services because of equipment malfunction or other problem, such time shall be at the expense of CONTRACTOR, with no change in Contract Price.
- B. "Days" specified shall consist of 8-hour days on-site, excluding travel time.
- C. CONTRACTOR shall designate and provide one person to be responsible for scheduling, coordinating, and expediting the specified services. Scheduling the services shall be done in cooperation with, and with the prior approval of ENGINEER and OWNER. Such schedule shall be arranged with the appropriate subcontractors, manufacturers, and suppliers with sufficient time to allow their compliance with the service requirements.
- D. CONTRACTOR shall manage equipment checkout such that checkout has been completed and deficiencies addressed prior to demonstration and training. Scheduling training prior to checkout may result in cancellation when checkout cannot be completed prior to training.

1.03 EQUIPMENT AND SYSTEM INSTALLATION

- A. Competent and experienced technical personnel shall represent the manufacturers of all equipment and systems for as many days as may be necessary to provide proper installation and to resolve assembly or installation problems at the site that are attributable to, or associated with, the equipment furnished. This requirement applies to manufacturers for all equipment furnished, whether or not specifically set forth in the Specifications.
- B. Where a Certificate of Proper Installation is called for in this Specification Section, the manufacturer's representative shall provide the attached Certificate of Proper Installation stating that the equipment or system has been installed in accordance with the manufacturer's instructions and has been inspected by a manufacturer's authorized representative, that it has been serviced with the proper initial lubricants, that applicable

safety equipment has been properly installed, that the proper electrical and mechanical connections have been made, and that any other manufacturer requirements have been met. This certification shall be provided to ENGINEER and OWNER prior to the start-up. This certificate is in addition to the manufacturer's standard startup reports, checklists, and other pertinent information.

- C. Functional (or run) testing is required for all equipment and systems. The manufacturer's representative shall supervise the functional test, which shall include checking for proper rotation, alignment, speed, excessive vibration, and noisy operation. The Manufacturer's Certificate of Proper Installation shall state that proper adjustments have been made and that the equipment or system is ready for start-up.
- D. Manufacturer shall demonstrate, using laser alignment equipment, if appropriate, that the installed equipment has been aligned properly. Final acceptance of equipment will not be granted until manufacturer has demonstrated to ENGINEER that acceptable alignment to tolerances have been achieved. For pumps with motors 7.5 hp and larger, the acceptable shaft alignment tolerances shall be as recommended in the pump manufacturer's written instructions and shall include parallel offset and angular gap measurements.

1.04 STARTING EQUIPMENT AND SYSTEMS

- A. Where field testing and start-up services are called for in the Specifications, or when technical assistance is necessary as a result of any malfunction of the equipment or system furnished, the manufacturer's representative shall provide such services.
- B. Manufacturer's representative shall also conduct and/or assist with performance testing, as required by the Specifications. These services shall continue until such times as the applicable equipment or system has been successfully tested for performance and has been accepted by OWNER for full-time operation.
- C. Coordinate schedule for start-up of various equipment and systems. Coordination includes, but is not limited to, communication with subcontractors, suppliers, OWNER, and ENGINEER. CONTRACTOR shall confirm that all necessary work is complete and that the equipment and systems can be operated in conjunction with all associated processes.
- D. Notify ENGINEER and OWNER a minimum of 7 days prior to start-up of each item using the attached Equipment Startup and O&M Training Scheduling form. CONTRACTOR shall submit form to ENGINEER.
- E. Verify that each piece of equipment or system has been checked for proper lubrication, drive rotation, belt tension, control sequence, or for other conditions that may cause damage.
- F. Verify that tests, meter readings, and specified electrical characteristics agree with those required by the equipment or system manufacturer.
- G. Verify wiring and support components for equipment are complete and tested.
- H. Execute start-up under supervision of applicable manufacturer's representative and CONTRACTOR's personnel in accordance with manufacturers' instructions.

- I. Require manufacturer to provide authorized representative to be present at site to inspect, check, and approve equipment or system installation prior to start-up and to supervise placing equipment or system in operation. Authorized representative shall provide approval for starting of systems in writing where specified.
- J. Equipment manufacturer shall provide a written report covering checkout, testing, inspections, and start-up and shall identify any deficiencies noted. Report shall be submitted to ENGINEER. CONTRACTOR shall be responsible for correcting all deficiencies noted in report. In addition, CONTRACTOR shall submit a fully executed Certificate of Proper Installation form if required in Paragraph 3.01 of this section.

1.05 DEMONSTRATION, INSTRUCTIONS, AND OPERATOR TRAINING

- A. For all mechanical equipment and systems and where called for in the Specifications, provide a qualified technical representative to provide detailed instructions to OWNER's personnel for operation and maintenance of equipment and associated instrumentation. Training services shall include pre-start-up classroom instruction and start-up on-site instruction, as stated in the Specifications.
- B. Refer to the Specifications for additional training requirements.
- C. CONTRACTOR shall coordinate the pre-start-up training periods with OWNER's operating personnel and manufacturers' representatives.
 - 1. Schedule training dates and times with OWNER, that are acceptable to OWNER, using equipment, startup, and O&M training form. Normal hours available for training are between 7:30 A.M. to 3 P.M., Monday through Friday, except for holidays.
 - 2. Submit outline and presentation to ENGINEER at least 7 days in advance of training.
 - 3. Provide name, contact information, and brief synopsis of qualifications of the trainer.
 - 4. If materials above are not provided at least 7 days in advance, training may be canceled.
 - 5. Failure of supplier's or manufacturer's representative to appear for scheduled training, failure to notify OWNER 24 hours in advance of need to cancel scheduled training or failure to arrive within 30 minutes of start of scheduled training shall result in reimbursement to OWNER for time lost by OWNER's personnel in waiting for arrival of manufacturer's representative. Except in case of failure to arrive on time, time will not exceed 1 hour for each employee scheduled to receive training. Failure to arrive on time will be reimbursed by actual time late, up to 1 hour, after 1 hour, training will be rescheduled. CONTRACTOR shall reimburse OWNER via a change order.
 - 6. During the training, instructor will dedicate its time solely to training and not start-up services.
 - 7. Utilize operation and maintenance manuals as basis for instruction. Review contents of manual with OWNER's personnel in detail to explain all aspects of operation and maintenance.
 - 8. Demonstrate start-up, operation, control, adjustment, troubleshooting, servicing, maintenance, and shutdown of each item of equipment.
 - 9. Prepare and insert additional data in operation and maintenance manuals when need for additional data becomes apparent during instruction.
 - 10. OWNER may videorecord the training for future internal use. Provide to OWNER paper and electronic copies of any media used as part of training.

11. Provide training handouts for each of OWNER's personnel present.

- D. CONTRACTOR shall provide attached Certificate of Operator Training cosigned by OWNER and supplier's representative verifying training was accomplished to satisfaction of all parties.
- E. Operation and maintenance manual submitted in accordance with Section 01 33 00—Submittals shall be provided prior to operator training.
- F. For equipment or systems requiring seasonal operation, perform demonstration for dormant season at start of dormant season.
- G. Final payment for various items of equipment will not be made by OWNER until the equipment is operating to OWNER's satisfaction.
- H. Where items of equipment are placed into service at different times or sequence, manufacturer's services for start-up, field testing, and supervision shall be provided for each time or sequence. Training shall be provided prior to or at the time the first similar item of equipment is placed in service.

1.06 START-UP AND TESTING

- A. Prior to acceptance of any portion of the Work, start-up and testing of all equipment and testing of all materials furnished on the Project by CONTRACTOR shall have been conducted in the presence of representatives of CONTRACTOR, OWNER, and ENGINEER and also manufacturer if requested by OWNER or ENGINEER.
- B. CONTRACTOR shall provide whatever temporary installations and conditions are necessary in order to perform start-up and testing operations on all equipment and materials furnished under the Contract. Temporary connections and equipment necessary during start-up and testing operations shall include, but not be limited to, temporary piping and electrical power and control equipment and devices, temporary connection from various parts of the systems and any other labor, materials, fuel, devices, or items that may be required for start-up and testing operations. Temporary conditions shall include filling with water, if necessary, to check equipment and materials.
- C. All temporary installations and conditions shall be removed by CONTRACTOR upon completion of start-up and testing.

PART 2—PRODUCTS

NOT APPLICABLE

PART 3—EXECUTION

3.01 EQUIPMENT SYSTEMS REQUIRING CERTIFICATION OF PROPER INSTALLATION

- A. Section 26 32 13.1—Standby Power System.

B. Section 26 36 23—Automatic Transfer Switches.

END OF SECTION

TS No. _____

EQUIPMENT START-UP AND O&M TRAINING SCHEDULING FORM
STRAND ASSOCIATES, INC.®

PROJECT _____ CLIENT _____

CONTRACT _____

CONTRACTOR _____ Date: _____

The following equipment is scheduled for start-up on _____

EQUIPMENT NAME: _____ SPECIFICATION SECTION: _____

MANUFACTURER: _____ MINIMUM HOURS OF TRAINING: _____

DATE O&M MANUALS SUBMITTED: _____

Specification Section 01 91 00 requires that start-up and operation and training be conducted by a qualified manufacturer's representative prior to placing equipment in operation. Review Specification Sections 01 33 00 and 01 45 00 and the individual equipment sections for start-up and training requirements. OWNER may find it necessary to propose alternate dates for training based on conflicts with other training and staff availability. The Operation and Maintenance Manuals must be submitted prior to training.

After the equipment or system has been properly installed and is functioning correctly, submit a written report in accordance with Specification Section 01 45 00.

Submit the completed form to ENGINEER and OWNER at least 7 days prior to start-up and training.

Proposed Training Date: _____ Time of Training: _____

Factory-trained representative giving training:

Name(s): _____

Company: _____

Address: _____

Phone: _____

Fax: _____

E-mail: _____

CERTIFICATE OF PROPER INSTALLATION

Project _____

Equipment _____

Specification Section _____

Contract _____

I hereby certify the equipment supplier/manufacture has inspected this equipment and that it has been properly installed, adjusted, and calibrated. I further certify this equipment may now be operated for test purposes and/or normal use.

MANUFACTURER'S REPRESENTATIVE

Signature _____ Date _____

Name (print) _____

Title _____

Representing _____

CONTRACTOR

Signature _____ Date _____

Name (print) _____

Title _____

This form shall be completed and submitted to ENGINEER prior to OWNER training.

CERTIFICATE OF OPERATOR TRAINING

Project _____

Equipment _____

Specification Section _____

Contract _____

I hereby certify the equipment supplier/manufacturer has instructed OWNER's personnel in the start-up operation and maintenance of this equipment as required in the Specifications.

MANUFACTURER'S REPRESENTATIVE

Signature _____ Date _____

Name (print) _____

Title _____

Representing _____

CONTRACTOR

Signature _____ Date _____

Name (print) _____

Title _____

OWNER

I hereby state that my operating personnel received instruction for start-up, operation, and maintenance of this equipment.

Signature _____ Date _____

Name (print) _____

Title _____

END SECTION

WAGE RATES

Kendall County Prevailing Wage Rates posted on 1/15/2026

Trade Title	Rg	Type	C	Base	Foreman	Overtime					Pension	Vac	Trng	Other Ins	Add OT 1.5x owed	Add OT 2.0x owed
						M-F	Sa	Su	Hol	H/W						
ASBESTOS ABT-GEN	All	ALL		51.40	52.40	1.5	1.5	2.0	2.0	16.23	19.80	0.00	0.91	0.00	0.00	0.00
ASBESTOS ABT-MEC	All	BLD		42.02	45.38	1.5	1.5	2.0	2.0	16.44	16.64	0.00	0.92		3.37	6.73
BOILERMAKER	All	BLD		58.91	64.21	2.0	2.0	2.0	2.0	7.07	27.02	0.00	3.69	2.31	0.00	39.30
BRICK MASON	All	BLD		53.06	58.37	1.5	1.5	2.0	2.0	12.95	26.26	0.00	1.57	0.00	4.23	8.45
CARPENTER	All	ALL		56.71	58.71	1.5	1.5	2.0	2.0	13.64	27.87	2.01	1.04		0.00	0.00
CEMENT MASON	All	ALL		52.15	54.15	2.0	1.5	2.0	2.0	12.86	30.96	0.00	0.80	0.00	0.00	0.00
CERAMIC TILE FINISHER	All	BLD		49.09	49.09	1.5	1.5	2.0	2.0	13.25	17.61	0.00	1.37	0.00	5.57	11.14
CERAMIC TILE LAYER	All	BLD		57.04	62.04	1.5	1.5	2.0	2.0	13.25	21.60	0.00	1.50	0.00	7.63	15.26
COMMUNICATION TECHNICIAN	All	BLD		49.70	53.20	1.5	1.5	2.0	2.0	17.30	19.41	0.00	1.74	0.00	0.00	0.00
CONCRETE SPECIALIST	All	BLD		51.81	58.21	1.5	1.5	2.0	2.0	12.95	27.56	0.00	1.57	0.00	4.88	9.75
CONCRETE SPECIALIST WELDER	All	BLD		54.40	58.21	1.5	1.5	2.0	2.0	12.95	27.56	0.00	1.57	0.00	4.88	9.75
ELECTRIC PWR EQMT OP	All	ALL		52.47	71.60	1.5	1.5	2.0	2.0	7.50	14.69	0.00	1.84	1.57	9.05	18.10
ELECTRIC PWR GRNDMAN	All	ALL		40.31	71.60	1.5	1.5	2.0	2.0	7.50	11.29	0.00	1.41	1.21	6.96	13.91
ELECTRIC PWR LINEMAN	All	ALL		63.08	71.60	1.5	1.5	2.0	2.0	7.50	17.66	0.00	2.21	1.89	10.88	21.76
ELECTRIC PWR TRK DRV	All	ALL		41.77	71.60	1.5	1.5	2.0	2.0	7.50	11.70	0.00	1.47	1.25	7.20	14.40
ELECTRICIAN	All	BLD		60.17	66.19	1.5	1.5	2.0	2.0	17.55	23.84	0.00	2.11		0.00	0.00
ELEVATOR CONSTRUCTOR	All	BLD		70.68	79.52	2.0	2.0	2.0	2.0	16.28	21.36	5.65	0.80		0.00	0.00
GLAZIER	All	BLD		53.55	55.05	1.5	2.0	2.0	2.0	16.04	26.64	0.00	2.30	0.00	0.00	0.00
HEAT/FROST INSULATOR	All	BLD		56.02	59.38	1.5	1.5	2.0	2.0	16.44	19.88	0.00	0.92		4.99	9.97
IRON WORKER	N	ALL		53.25	58.58	2.0	2.0	2.0	2.0	14.61	31.31	0.00	1.10	0.00	0.00	0.00
IRON WORKER	S	ALL		52.00	57.20	2.0	2.0	2.0	2.0	14.61	30.95	0.00	1.10	0.00	0.00	0.00
LABORER	All	ALL		51.40	52.15	1.5	1.5	2.0	2.0	16.23	19.80	0.00	0.91	0.00	0.00	0.00
LATHER	All	ALL		56.71	58.71	1.5	1.5	2.0	2.0	13.64	27.87	2.01	1.04		0.00	0.00
MACHINIST	All	BLD		60.39	64.39	1.5	1.5	2.0	2.0	11.43	9.95	1.85	1.47	0.00	0.00	0.00
MARBLE FINISHER	All	ALL		40.21	54.60	1.5	1.5	2.0	2.0	12.95	23.81	0.00	0.98	0.00	3.00	6.00
MARBLE SETTER	All	BLD		52.00	57.20	1.5	1.5	2.0	2.0	12.95	25.57	0.00	1.25	0.00	3.88	7.76

Kendall County Prevailing Wage Rates posted on 1/15/2026

MATERIAL TESTER I	All	ALL		41.40		1.5	1.5	2.0	2.0	16.23	19.80	0.00	0.91	0.00	0.00	0.00
MATERIALS TESTER II	All	ALL		46.40		1.5	1.5	2.0	2.0	16.23	19.80	0.00	0.91	0.00	0.00	0.00
MILLWRIGHT	All	ALL		56.71	58.71	1.5	1.5	2.0	2.0	13.64	27.87	2.01	1.04		0.00	0.00
OPERATING ENGINEER	All	BLD	1	64.80	68.80	2.0	2.0	2.0	2.0	24.70	21.55	2.00	2.75		0.00	0.00
OPERATING ENGINEER	All	BLD	2	63.50	68.80	2.0	2.0	2.0	2.0	24.70	21.55	2.00	2.75	0.00	0.00	0.00
OPERATING ENGINEER	All	BLD	3	60.95	68.80	2.0	2.0	2.0	2.0	24.70	21.55	2.00	2.75		0.00	0.00
OPERATING ENGINEER	All	BLD	4	59.20	68.80	2.0	2.0	2.0	2.0	24.70	21.55	2.00	2.75		0.00	0.00
OPERATING ENGINEER	All	BLD	5	68.55	68.80	2.0	2.0	2.0	2.0	24.70	21.55	2.00	2.75		0.00	0.00
OPERATING ENGINEER	All	BLD	6	65.80	68.80	2.0	2.0	2.0	2.0	24.70	21.55	2.00	2.75		0.00	0.00
OPERATING ENGINEER	All	BLD	7	67.80	68.80	2.0	2.0	2.0	2.0	24.70	21.55	2.00	2.75		0.00	0.00
OPERATING ENGINEER	All	FLT		53.25	53.25	1.5	1.5	2.0	2.0	25.20	22.75	2.00	3.00		0.00	0.00
OPERATING ENGINEER	All	HWY	1	63.00	67.00	1.5	1.5	2.0	2.0	24.70	21.55	2.00	2.75		0.00	0.00
OPERATING ENGINEER	All	HWY	2	62.45	67.00	1.5	1.5	2.0	2.0	24.70	21.55	2.00	2.75		0.00	0.00
OPERATING ENGINEER	All	HWY	3	60.40	67.00	1.5	1.5	2.0	2.0	24.70	21.55	2.00	2.75		0.00	0.00
OPERATING ENGINEER	All	HWY	4	59.00	67.00	1.5	1.5	2.0	2.0	24.70	21.55	2.00	2.75		0.00	0.00
OPERATING ENGINEER	All	HWY	5	57.80	67.00	1.5	1.5	2.0	2.0	24.70	21.55	2.00	2.75		0.00	0.00
OPERATING ENGINEER	All	HWY	6	66.00	67.00	1.5	1.5	2.0	2.0	24.70	21.55	2.00	2.75		0.00	0.00
OPERATING ENGINEER	All	HWY	7	64.00	67.00	1.5	1.5	2.0	2.0	24.70	21.55	2.00	2.75		0.00	0.00
PAINTER	All	ALL		54.30	56.30	1.5	1.5	1.5	2.0	16.20	11.43	0.00	1.75	0.00	0.00	0.00
PAINTER - SIGNS	All	BLD		48.16	54.11	1.5	1.5	2.0	2.0	8.20	16.81	0.00	0.00	0.00	0.00	0.00
PILEDRIIVER	All	ALL		56.71	58.71	1.5	1.5	2.0	2.0	13.64	27.87	2.01	1.04		0.00	0.00
PIPEFITTER	All	BLD		58.50	61.50	1.5	1.5	2.0	2.0	15.15	22.85	0.00	3.12	0.00	0.00	0.00
PLASTERER	All	BLD		51.10	54.17	1.5	1.5	2.0	2.0	18.43	22.10	0.00	1.25	0.00	0.00	0.00
PLUMBER	All	BLD		60.50	64.15	1.5	1.5	2.0	2.0	19.10	17.94	0.00	1.98		0.00	0.00
ROOFER	All	BLD		52.00	57.00	1.5	1.5	2.0	2.0	12.80	18.19	0.00	1.14	0.00	0.00	0.00
SHEETMETAL WORKER	All	BLD		58.83	63.54	1.5	1.5	2.0	2.0	17.16	19.90	0.00	1.79	2.62	0.00	0.00
SPRINKLER FITTER	All	BLD		63.20	65.95	1.5	1.5	2.0	2.0	15.45	19.95	0.00	1.15	0.00	0.00	0.00
STONE MASON	All	BLD		53.06	58.37	1.5	1.5	2.0	2.0	12.95	26.26	0.00	1.57	0.00	4.23	8.45
SURVEY WORKER	All	BLD		51.40	52.15	1.5	1.5	2.0	2.0	16.23	19.80	0.00	0.91	0.00	0.00	0.00
SURVEY WORKER	All	HWY		51.40	52.15	1.5	1.5	2.0	2.0	16.23	19.80	0.00	0.91	0.00	0.00	0.00

Kendall County Prevailing Wage Rates posted on 1/15/2026

TERRAZZO FINISHER	All	BLD		51.44	51.44	1.5	1.5	2.0	2.0	13.25	18.87	0.00	1.41	0.00	4.45	8.89
TERRAZZO MECHANIC	All	BLD		55.35	58.85	1.5	1.5	2.0	2.0	13.25	20.26	0.00	1.46	0.00	4.70	9.39
TRUCK DRIVER	All	ALL	1	47.95	48.50	1.5	1.5	2.0	2.0	12.15	14.31	0.00	0.35	0.00	0.00	0.00
TRUCK DRIVER	All	ALL	2	48.10	48.50	1.5	1.5	2.0	2.0	12.15	14.31	0.00	0.35		0.00	0.00
TRUCK DRIVER	All	ALL	3	48.30	48.50	1.5	1.5	2.0	2.0	12.15	14.31	0.00	0.35	0.00	0.00	0.00
TRUCK DRIVER	All	ALL	4	48.50	48.50	1.5	1.5	2.0	2.0	12.15	14.31	0.00	0.35	0.00	0.00	0.00
TUCK POINTER	All	BLD		52.53	53.53	1.5	1.5	2.0	2.0	11.05	23.16	0.00	1.46	0.00	0.00	0.00

Legend

Rg Region

Type Trade Type - All,Highway,Building,Floating,Oil & Chip,Rivers

C Class

Base Base Wage Rate

OT M-F Unless otherwise noted, OT pay is required for any hour greater than 8 worked each day, Mon through Fri. The number listed is the multiple of the base wage.

OT Sa Overtime pay required for every hour worked on Saturdays

OT Su Overtime pay required for every hour worked on Sundays

OT Hol Overtime pay required for every hour worked on Holidays

H/W Health/Welfare benefit

Vac Vacation

Trng Training

Other Ins Employer hourly cost for any other type(s) of insurance provided for benefit of worker.

Explanations KENDALL COUNTY

The following list is considered as those days for which holiday rates of wages for work performed apply: New Years Day, Memorial Day, Fourth of July, Labor Day, Thanksgiving Day, Christmas Day and Veterans Day in some classifications/counties. Generally, any of these holidays which fall on a Sunday is celebrated on the following Monday. This then makes work performed on that Monday payable at the appropriate overtime rate for holiday pay. Common practice in a given local may alter certain days of celebration. If in doubt, please check with IDOL.

Iron Workers North - Starting from the Will County and Kendall County border at Rt. 126 and County Line Road. Follow Rt. 126 West to Grove Road. Grove Road South to Caton Farm Road. Caton Farm Road West to Lisbon Road. Lisbon Road South to Route 52. Rt. 52 West to County Line Road at the LaSalle / Kendall County Line.

EXPLANATION OF CLASSES

ASBESTOS - GENERAL - removal of asbestos material/mold and hazardous materials from any place in a building, including

Kendall County Prevailing Wage Rates posted on 1/15/2026

mechanical systems where those mechanical systems are to be removed. This includes the removal of asbestos materials/mold and hazardous materials from ductwork or pipes in a building when the building is to be demolished at the time or at some close future date.

ASBESTOS - MECHANICAL - removal of asbestos material from mechanical systems, such as pipes, ducts, and boilers, where the mechanical systems are to remain. CERAMIC TILE FINISHER

The grouting, cleaning, and polishing of all classes of tile, whether for interior or exterior purposes, all burned, glazed or unglazed products; all composition materials, granite tiles, warning detectable tiles, cement tiles, epoxy composite materials, pavers, glass, mosaics, fiberglass, and all substitute materials, for tile made in tile-like units; all mixtures in tile like form of cement, metals, and other materials that are for and intended for use as a finished floor surface, stair treads, promenade roofs, walks, walls, ceilings, swimming pools, and all other places where tile is to form a finished interior or exterior. The mixing of all setting mortars including but not limited to thin-set mortars, epoxies, wall mud, and any other sand and cement mixtures or adhesives when used in the preparation, installation, repair, or maintenance of tile and/or similar materials. The handling and unloading of all sand, cement, lime, tile, fixtures, equipment, adhesives, or any other materials to be used in the preparation, installation, repair, or maintenance of tile and/or similar materials. Ceramic Tile Finishers shall fill all joints and voids regardless of method on all tile work, particularly and especially after installation of said tile work. Application of any and all protective coverings to all types of tile installations including, but not be limited to, all soap compounds, paper products, tapes, and all polyethylene coverings, plywood, masonite, cardboard, and any new type of products that may be used to protect tile installations, Blastrac equipment, and all floor scarifying equipment used in preparing floors to receive tile. The clean up and removal of all waste and materials. All demolition of existing tile floors and walls to be re-tiled.

COMMUNICATIONS TECHNICIAN

Construction, installation, maintenance and removal of telecommunication facilities (voice, sound, data and video), telephone, security, and data inside wire, interconnect, terminal equipment, central offices, PABX and equipment, micro waves, V-SAT, bypass, CATV, WAN (wide area network), LAN (local area networks), and ISDN (integrated system digital network), pulling of wire in raceways, but not the installation of raceways.

MARBLE FINISHER

Loading and unloading trucks, distribution of all materials (all stone, sand, etc.), stocking of floors with material, performing all rigging for heavy work, the handling of all material that may be needed for the installation of such materials, building of scaffolding, polishing if needed, patching, waxing of material if damaged, pointing up, caulking, grouting and cleaning of marble, holding water on diamond or Carborundum blade or saw for setters cutting, use of tub saw or any other saw needed for preparation of material, drilling of holes for wires that anchor material set by setters, mixing up of molding plaster for installation of material, mixing up thin set for the installation of material, mixing up of sand to cement for the installation of material and such other work as may be required in helping a Marble Setter in the handling of all material in the erection or installation of interior marble, slate, travertine, art marble, serpentine, alberene stone, blue stone, granite and other stones (meaning as to stone any foreign or domestic materials as are specified and used in building interiors and exteriors and customarily known as stone in the trade), carrara, sanionyx, vitrolite and similar opaque glass and the laying of all marble tile, terrazzo tile, slate tile and precast tile, steps, risers treads, base, or any other materials that may be used as substitutes for any of the aforementioned materials and

Kendall County Prevailing Wage Rates posted on 1/15/2026

which are used on interior and exterior which are installed in a similar manner.

MATERIAL TESTER I: Hand coring and drilling for testing of materials; field inspection of uncured concrete and asphalt.

MATERIAL TESTER II: Field inspection of welds, structural steel, fireproofing, masonry, soil, facade, reinforcing steel, formwork, cured concrete, and concrete and asphalt batch plants; adjusting proportions of bituminous mixtures.

OPERATING ENGINEER - BUILDING

Class 1. Asphalt Plant; Asphalt Spreader; Autograde; Backhoes with Caisson Attachment; Batch Plant; Benoto (requires Two Engineers); Boiler and Throttle Valve; Caisson Rigs; Central Redi-Mix Plant; Combination Back Hoe Front End-loader Machine; Compressor and Throttle Valve; Concrete Breaker (Truck Mounted); Concrete Conveyor; Concrete Conveyor (Truck Mounted); Concrete Paver Over 27E cu. ft; Concrete Paver 27E cu. ft. and Under; Concrete Placer; Concrete Placing Boom; Concrete Pump (Truck Mounted); Concrete Tower; Cranes, All; Cranes, Hammerhead; Cranes, (GCI and similar Type); Creter Crane; Spider Crane; Crusher, Stone, etc.; Derricks, All; Derricks, Traveling; Formless Curb and Gutter Machine; Grader, Elevating; Grouting Machines; Heavy Duty Self-Propelled Transporter or Prime Mover; Highlift Shovels or Front Endloader 2-1/4 yd. and over; Hoists, Elevators, outside type rack and pinion and similar machines; Hoists, One, Two and Three Drum; Hoists, Two Tugger One Floor; Hydraulic Backhoes; Hydraulic Boom Trucks; Hydro Vac (and similar equipment); Locomotives, All; Motor Patrol; Lubrication Technician; Manipulators; Pile Drivers and Skid Rig; Post Hole Digger; Pre-Stress Machine; Pump Cretes Dual Ram; Pump Cretes: Squeeze Cretes-Screw Type Pumps; Gypsum Bulker and Pump; Raised and Blind Hole Drill; Roto Mill Grinder; Scoops - Tractor Drawn; Slip-Form Paver; Straddle Buggies; Operation of Tie Back Machine; Tournapull; Tractor with Boom and Side Boom; Trenching Machines.

Class 2. Boilers; Broom, All Power Propelled; Bulldozers; Concrete Mixer (Two Bag and Over); Conveyor, Portable; Forklift Trucks; Highlift Shovels or Front Endloaders under 2-1/4 yd.; Hoists, Automatic; Hoists, Inside Elevators; Hoists, Sewer Dragging Machine; Hoists, Tugger Single Drum; Laser Screed; Rock Drill (Self-Propelled); Rock Drill (Truck Mounted); Rollers, All; Steam Generators; Tractors, All; Tractor Drawn Vibratory Roller; Winch Trucks with "A" Frame.

Class 3. Air Compressor; Combination Small Equipment Operator; Generators; Heaters, Mechanical; Hoists, Inside Elevators (remodeling or renovation work); Hydraulic Power Units (Pile Driving, Extracting, and Drilling); Pumps, over 3" (1 to 3 not to exceed a total of 300 ft.); Low Boys; Pumps, Well Points; Welding Machines (2 through 5); Winches, 4 Small Electric Drill Winches.

Class 4. Bobcats and/or other Skid Steer Loaders; Oilers; and Brick Forklift.

Class 5. Assistant Craft Foreman.

Class 6. Gradall.

Class 7. Mechanics; Welder.

OPERATING ENGINEERS - HIGHWAY CONSTRUCTION

Class 1. Asphalt Plant; Asphalt Heater and Planer Combination; Asphalt Heater Scarfire; Asphalt Spreader; Autograder/GOMACO

Kendall County Prevailing Wage Rates posted on 1/15/2026

or other similar type machines: ABG Paver; Backhoes with Caisson Attachment; Ballast Regulator; Belt Loader; Caisson Rigs; Car Dumper; Central Redi-Mix Plant; Combination Backhoe Front Endloader Machine, (1 cu. yd. Backhoe Bucket or over or with attachments); Concrete Breaker (Truck Mounted); Concrete Conveyor; Concrete Paver over 27E cu. ft.; Concrete Placer; Concrete Tube Float; Cranes, all attachments; Cranes, Tower Cranes of all types: Creter Crane: Spider Crane; Crusher, Stone, etc.; Derricks, All; Derrick Boats; Derricks, Traveling; Dredges; Elevators, Outside type Rack & Pinion and Similar Machines; Formless Curb and Gutter Machine; Grader, Elevating; Grader, Motor Grader, Motor Patrol, Auto Patrol, Form Grader, Pull Grader, Subgrader; Guard Rail Post Driver Truck Mounted; Hoists, One, Two and Three Drum; Heavy Duty Self-Propelled Transporter or Prime Mover; Hydraulic Backhoes; Backhoes with shear attachments up to 40' of boom reach; Lubrication Technician; Manipulators; Mucking Machine; Pile Drivers and Skid Rig; Pre-Stress Machine; Pump Cretes Dual Ram; Rock Drill - Crawler or Skid Rig; Rock Drill - Truck Mounted; Rock/Track Tamper; Roto Mill Grinder; Slip-Form Paver; Snow Melters; Soil Test Drill Rig (Truck Mounted); Straddle Buggies; Hydraulic Telescoping Form (Tunnel); Operation of Tieback Machine; Tractor Drawn Belt Loader; Tractor Drawn Belt Loader (with attached pusher - two engineers); Tractor with Boom; Tractaire with Attachments; Traffic Barrier Transfer Machine; Trenching; Truck Mounted Concrete Pump with Boom; Raised or Blind Hole Drills (Tunnel Shaft); Underground Boring and/or Mining Machines 5 ft. in diameter and over tunnel, etc; Underground Boring and/or Mining Machines under 5 ft. in diameter; Wheel Excavator; Widener (APSCO).

Class 2. Batch Plant; Bituminous Mixer; Boiler and Throttle Valve; Bulldozers; Car Loader Trailing Conveyors; Combination Backhoe Front Endloader Machine (Less than 1 cu. yd. Backhoe Bucket or over or with attachments); Compressor and Throttle Valve; Compressor, Common Receiver (3); Concrete Breaker or Hydro Hammer; Concrete Grinding Machine; Concrete Mixer or Paver 7S Series to and including 27 cu. ft.; Concrete Spreader; Concrete Curing Machine, Burlap Machine, Belting Machine and Sealing Machine; Concrete Wheel Saw; Conveyor Muck Cars (Haglund or Similar Type); Drills, All; Finishing Machine - Concrete; Highlift Shovels or Front Endloader; Hoist - Sewer Dragging Machine; Hydraulic Boom Trucks (All Attachments); Hydro-Blaster; Hydro Excavating (excluding hose work); Laser Screed; All Locomotives, Dinky; Off-Road Hauling Units (including articulating) Non Self-Loading Ejection Dump; Pump Cretes: Squeeze Cretes - Screw Type Pumps, Gypsum Bulker and Pump; Roller, Asphalt; Rotary Snow Plows; Rototiller, Seaman, etc., self-propelled; Self-Propelled Compactor; Spreader - Chip - Stone, etc.; Scraper - Single/Twin Engine/Push and Pull; Scraper - Prime Mover in Tandem (Regardless of Size); Tractors pulling attachments, Sheeps Foot, Disc, Compactor, etc.; Tug Boats.

Class 3. Boilers; Brooms, All Power Propelled; Cement Supply Tender; Compressor, Common Receiver (2); Concrete Mixer (Two Bag and Over); Conveyor, Portable; Farm-Type Tractors Used for Mowing, Seeding, etc.; Forklift Trucks; Grouting Machine; Hoists, Automatic; Hoists, All Elevators; Hoists, Tugger Single Drum; Jeep Diggers; Low Boys; Pipe Jacking Machines; Post-Hole Digger; Power Saw, Concrete Power Driven; Pug Mills; Rollers, other than Asphalt; Seed and Straw Blower; Steam Generators; Stump Machine; Winch Trucks with "A" Frame; Work Boats; Tamper-Form-Motor Driven.

Class 4. Air Compressor; Combination - Small Equipment Operator; Directional Boring Machine; Generators; Heaters, Mechanical; Hydraulic Power Unit (Pile Driving, Extracting, or Drilling); Light Plants, All (1 through 5); Pumps, over 3" (1 to 3 not to exceed a total of 300 ft.); Pumps, Well Points; Vacuum Trucks (excluding hose work); Welding Machines (2 through 5); Winches, 4 Small Electric Drill Winches.

Class 5. SkidSteer Loader (all); Brick Forklifts; Oilers.

Kendall County Prevailing Wage Rates posted on 1/15/2026

Class 6. Field Mechanics and Field Welders

Class 7. Dowell Machine with Air Compressor; Gradall and machines of like nature.

OPERATING ENGINEERS - FLOATING

Diver. Diver Wet Tender, Diver Tender, ROV Pilot, ROV Tender

SURVEY WORKER

Operates survey equipment (such as levels, transits, data collectors, GPS and robotic total stations) for the purpose of performing construction layout and/or grade checking.

SURVEY FOREMAN

Operates survey equipment (such as levels, transits, data collectors, GPS and robotic total stations) for the purpose of performing construction layout and/or grade checking; oversees survey crew operations; and/or coordinates work of survey crews.

TRUCK DRIVER - BUILDING, HEAVY AND HIGHWAY CONSTRUCTION

Class 1. Two or three Axle Trucks. A-frame Truck when used for transportation purposes; Air Compressors and Welding Machines, including those pulled by cars, pick-up trucks and tractors; Ambulances Batch Gate Lockers; Batch Hopperman; Car and Truck Washers; Carry-alls; Fork Lifts and Hoisters; Helpers; Mechanics Helpers and Greasers; Oil Distributors 2-man operation; Pavement Breakers; Pole Trailer, up to 40 feet; Power Mower Tractors; Self-propelled Chip Spreader; Skipman; Slurry Trucks, 2-man operation; Slurry Truck Conveyor Operation, 2 or 3 man; Teamsters; Unskilled Dumpman; and Truck Drivers hauling warning lights, barricades, and portable toilets on the job site.

Class 2. Four axle trucks; Dump Crets and Adgetors under 7 yards; Dumpsters, Track Trucks, Euclids, Hug Bottom Dump Turnapulls or Turnatrailers when pulling other than self-loading equipment or similar equipment under 16 cubic yards; Mixer Trucks under 7 yards; Ready-mix Plant Hopper Operator, and Winch Trucks, 2 Axles.

Class 3. Five axle trucks; Dump Crets and Adgetors 7 yards and over; Dumpsters, Track Trucks, Euclids, Hug Bottom Dump Turnatrailers or turnapulls when pulling other than self-loading equipment or similar equipment over 16 cubic yards; Explosives and/or Fission Material Trucks; Mixer Trucks 7 yards or over; Mobile Cranes while in transit; Oil Distributors, 1-man operation; Pole Trailer, over 40 feet; Pole and Expandable Trailers hauling material over 50 feet long; Slurry trucks, 1-man operation; Winch trucks, 3 axles or more; Mechanic--Truck Welder and Truck Painter.

Class 4. Six axle trucks; Dual-purpose vehicles, such as mounted crane trucks with hoist and accessories; Foreman; Master Mechanic; Self-loading equipment like P.B. and trucks with scoops on the front.

TERRAZZO FINISHER

The handling of sand, cement, marble chips, and all other materials that may be used by the Mosaic Terrazzo Mechanic, and the mixing, grinding, grouting, cleaning and sealing of all Marble, Mosaic, and Terrazzo work, floors, base, stairs, and wainscoting by

Kendall County Prevailing Wage Rates posted on 1/15/2026

hand or machine, and in addition, assisting and aiding Marble, Masonic, and Terrazzo Mechanics.

Other Classifications of Work:

For definitions of classifications not otherwise set out, the Department generally has on file such definitions which are available. If a task to be performed is not subject to one of the classifications of pay set out, the Department will upon being contacted state which neighboring county has such a classification and provide such rate, such rate being deemed to exist by reference in this document. If no neighboring county rate applies to the task, the Department shall undertake a special determination, such special determination being then deemed to have existed under this determination. If a project requires these, or any classification not listed, please contact IDOL at 217-782-1710 for wage rates or clarifications.

LANDSCAPING

Landscaping work falls under the existing classifications for laborer, operating engineer and truck driver. The work performed by landscape plantsman and landscape laborer is covered by the existing classification of laborer. The work performed by landscape operators (regardless of equipment used or its size) is covered by the classifications of operating engineer. The work performed by landscape truck drivers (regardless of size of truck driven) is covered by the classifications of truck driver.

MATERIAL TESTER & MATERIAL TESTER/INSPECTOR I AND II

Notwithstanding the difference in the classification title, the classification entitled "Material Tester I" involves the same job duties as the classification entitled "Material Tester/Inspector I". Likewise, the classification entitled "Material Tester II" involves the same job duties as the classification entitled "Material Tester/Inspector II".

SECTION 02 41 00

DEMOLITION

PART 1–GENERAL

1.01 SUMMARY

- A. Work Included: All demolition, removal, and salvage work as shown on the Drawings or specified herein to include, but not necessarily limited to the following:
 - 1. Booster Station No. 2 Generator Receptacle and Appurtenances.
 - 2. Booster Station No. 3 Manual Transfer Switch, Generator Receptacle, and Appurtenances.
- B. Related Sections and Divisions: Applicable provisions of Division 01 shall govern work in this section.

1.02 SUBMITTALS

- A. CONTRACTOR shall submit permits and notices, if required, authorizing building demolition.

1.03 QUALITY ASSURANCE

- A. CONTRACTOR shall perform demolition, removal, and salvage in conformity with applicable federal, state, and local safety practices and code requirements.
- B. CONTRACTOR shall contact all public utilities and shall shut off, cut and cap all utility services in accordance with utility requirements, codes, rules, and regulations.
- C. Obtain and pay for all necessary permits, licenses, and certificates required.

1.04 SEQUENCE

- A. No demolition, removal, or salvage work shall commence until approval to proceed has been granted by OWNER. Such work shall be completed in accordance with the construction sequence included in Division 01 of these Specifications and in accordance with the construction phases of this project and work to be done by other contractors.

PART 2–PRODUCTS

2.01 GENERAL

- A. Compacted fill shall meet the requirements of Section 31 23 00–Excavation, Fill, Backfill, and Grading.

PART 3–EXECUTION

3.01 EQUIPMENT

- A. CONTRACTOR shall remove all equipment specified herein or indicated.
- B. CONTRACTOR shall remove associated exposed conduit, power wiring, controls, switches, instrumentation, control wiring, control boxes, appurtenances, and their supports serving equipment to be removed. Electrical items shall be removed to their junction with motor control center, control panel, or their junction with conduit serving other equipment that is to remain.
- C. CONTRACTOR shall remove equipment bases, anchor bolts, and other supports serving equipment to be removed.
- D. CONTRACTOR shall patch floors, walls, and ceilings as required to match existing or as indicated where equipment electrical, bases, or supports are removed.

3.02 SALVAGE

- A. OWNER has first right of refusal to all material, piping, and equipment removed.
- B. All equipment, material, and piping, except as specified hereinafter, within the buildings and structures to be demolished and additional items as noted shall be removed by CONTRACTOR. CONTRACTOR shall inspect each structure and determine the type and amount of equipment, materials, and piping to be removed.
- C. All equipment, material, and piping, except as specified hereinafter, within the limits of the demolition and additional items noted to be removed, will become the property of CONTRACTOR if OWNER does not claim under first right of refusal and shall be removed from the project site. Comply with State and local ordinances and regulations for disposing of materials.
- D. If CONTRACTOR chooses to dispose of materials in a Clean Construction or Demolition Debris (CCDD) fill operation, CONTRACTOR shall provide all required testing, certifications and fees associated with using the CCDD fill operation.
- E. Manual Transfer Switch (MTS-03) shall be removed from Booster Station 3 and turned over to OWNER.

3.03 BACKFILL

- A. CONTRACTOR shall fill all abandoned structures and excavations resulting from removal of structures and utilities with compacted fill. See Section 31 23 00–Excavation, Fill, Backfill, and Grading for required degree of compaction.
- B. Prior to filling, CONTRACTOR shall break one opening in the floor or wall near the base of each compartment to allow groundwater to freely migrate through the structure.

END OF SECTION

00SECTION 03 11 00
CONCRETE FORMWORK

PART 1–GENERAL

1.01 SUMMARY

- A. Work Included:
 - 1. Forms for Cast-In-Place Concrete.
 - 2. Form Accessories.
 - 3. Openings for Other Work.
 - 4. Form Stripping.
- B. Related Sections and Divisions: Applicable provisions of Division 01 shall govern work in this section.

1.02 REFERENCES

- A. ACI 117–Tolerances for Concrete Construction.
- B. ACI 301–Structural Concrete for Buildings.
- C. ACI 318–Building Code Requirements for Reinforced Concrete.
- D. ACI 347–Recommended Practice for Concrete Formwork.
- E. PS1–Construction and Industrial Plywood.

1.03 DESIGN

- A. All formwork shall comply with ACI 347 and ACI 301.
- B. CONTRACTOR shall assume the responsibility for the complete design and construction of the formwork.

1.04 SUBMITTALS

- A. Submit shop drawings in accordance with Section 01 33 00–Submittals for form ties, form coatings, form liners (if any), and any other form accessories.
- B. Submit geometry of forms for circular structures.

PART 2–PRODUCTS

2.01 FORMS

- A. Forms shall be of wood, plywood, steel, fiberboard lined, or other approved materials which will produce concrete which meets the specified requirements. The type, size, quality, and shape of all materials of which the forms are made are subject to the review of ENGINEER.
- B. Caution shall be exercised in the use of wood or composition forms or form liner to be certain that no chemical reaction will take place which causes a damaging effect on the concrete surface.

2.02 FORM TIES–NONREMOVABLE

- A. Internal wall ties shall contain positive stops at the required wall thickness. The exterior clamp portions of the tie shall be adjustable in length. Ties shall have cones on the water side of water-containing structures. Ties shall also have cones on the exterior side of all structures which have PVC water-stopped construction joints. Ties shall provide a positive disconnection on both ends 1 to 1 1/2 inches inside the finished face of the concrete.
- B. All wall ties used in the placement of structures which have PVC or hydrophilic water-stopped construction joints shall contain integral waterstops. All such ties shall be crimped or deformed in such a manner that the bond between concrete and tie cannot be broken in removal of the outer units. This portion of the tie shall not be removed prior to 24 hours after completion of the concrete placement.
- C. The use of wood spacers and wire ties will not be approved.

2.03 FORM COATINGS

- A. Provide commercial formulation form-coating compounds that will not bond with, stain, nor adversely affect concrete surfaces requiring bond or adhesion, nor impede the wetting of surfaces to be cured with water or curing compounds.

2.04 CHAMFER STRIPS

- A. Provide 3/4-inch by 3/4-inch wood or plastic chamfer strips at all exposed corners, except as noted.

2.05 KEYWAYS

- A. Keyways shall be formed with wood inserts.

PART 3–EXECUTION

3.01 CONSTRUCTION

- A. Forms shall conform to the shape, line, grade, and dimensions as shown on the Drawings. They shall be mortar-tight and sufficiently rigid to prevent displacement or sagging between supports and shall support the loads and pressures without deflection from the prescribed

lines. They shall be properly braced or tied together so as to maintain position and shape. Spacing of ties shall be recommended by the tie manufacturer.

- B. Formwork and finished concrete construction shall meet the tolerances specified in ACI 117.
- C. All exposed curved surfaces shall be formed to the continuous surface of the radius specified. Where segmented forms are proposed, a form system which deviates more than 3/8 inch from a circle through pan edges will not be allowed.
- D. Architectural surfaces and surfaces to be fitted with equipment shall be formed to match the shape intended. Where indicated on the Drawings, the form shall be lined with minimum 3/8-inch masonite and shimmed as required.
- E. When forms are placed for successive concrete placement, thoroughly clean concrete surfaces, remove fins and laitance, and tighten forms to close all joints. Align and secure joints to avoid offsets.
- F. At the request of ENGINEER, temporary openings shall be provided at the base of column forms and wall forms and at other points where necessary to facilitate cleaning and observation immediately before depositing concrete.
- G. Provide inserts and provide openings in concrete form work to accommodate work of other trades. Verify size and location of openings, recesses, and chases with the trade requiring such items. Securely support items to be built into forms.
- H. Provide top forms for inclined surfaces where the slope is too steep to place and vibrate concrete.
- I. Bevel wood inserts for forming keyways (except in expansion joints where inserts shall have square edges), reglets, recesses, and the like to allow for ease of removal. Inserts shall be securely held in place prior to concrete placement. Unless otherwise shown, chamfer strips shall be placed in the angles of the forms to provide 3/4-inch bevels at exterior edges and corners of all exposed concrete.
- J. The forms shall be oiled with a field-applied commercial form oil or a factory-applied nonabsorptive liner. Oil shall not stain or impede the wetting of surfaces to be cured with water or curing compounds. The forms shall be coated prior to placing reinforcing steel. Oil on reinforcement will not be permitted.
- K. All form surfaces shall be thoroughly cleaned, patched, and repaired before reusing and are subject to review of ENGINEER.

3.02 FORM REMOVAL

- A. Supporting forms and shoring shall not be removed until the member has acquired sufficient strength to support its own weight and the construction live loads on it.
- B. All form removal shall be accomplished in such a manner that will prevent injury to the concrete.

- C. Forms shall not be removed before the expiration of the minimum times as stated below or until the concrete has attained its minimum 28-day design strength as confirmed by concrete cylinder tests, unless specifically authorized by ENGINEER.
1. Wall and Vertical Faces: 24 hours.
 2. Columns: 24 hours.
 3. Beams and Elevated Slabs: 14 days.

END OF SECTION

SECTION 03 20 00
CONCRETE REINFORCEMENT

PART 1–GENERAL

1.01 SUMMARY

- A. Work includes providing complete, in-place, all steel and fibers required for reinforcement of cast-in-place concrete as shown on the Drawings.
- B. Related Sections and Divisions: Applicable provisions of Division 01 shall govern work in this section.

1.02 REFERENCES

- A. Applicable standards listed in this section include, but are not necessarily limited to the following:
 - 1. ACI 315–Manual of Standard Practice for Detailing Reinforced Concrete Structures.
 - 2. ACI 318–Building Code Requirements for Reinforced Concrete.
 - 3. ASTM A1064–Standard Specifications for Carbon-Steel Wire and Welded Wire Reinforcement, Plain and Deformed, for Concrete.
 - 4. ASTM A615–Standard Specification for Deformed and Plain Billet-Steel Bars for Concrete Reinforcement.
 - 5. ASTM A996–Standard Specification for Rail-Steel and Axle-Steel Deformed Bars for Concrete Reinforcing.
 - 6. CRSI–Manual of Standard Practice.

1.03 SUBMITTALS

- A. Comply with pertinent provisions of Section 01 33 00–Submittals.
- B. Provide complete shop drawings of all material to be furnished and installed under this section:
 - 1. Before fabrication of the reinforcement is begun, CONTRACTOR shall obtain the approval of ENGINEER on reinforcing bar lists and placing drawings.
 - 2. These drawings and lists shall show in detail the number, size, length, bending, and arrangement of the reinforcing. Reinforcing supports shall also be located on the shop drawings.
 - 3. Shop drawings shall be in accordance with ACI 315.

1.04 PRODUCT HANDLING

- A. Delivery:
 - 1. Deliver reinforcement to the job site bundled, tagged, and marked.
 - 2. Use metal tags indicating bar size, lengths, and other information corresponding to markings shown on placement diagrams.
- B. Storage: Store reinforcement at the job site on blocks and in a manner to prevent damage and accumulation of dirt and excessive rust.

PART 2–PRODUCTS

2.01 MATERIALS

- A. Reinforcing bars shall comply with ASTM A615 or A996 Type R, Grade 60. Reinforcing bars required to be welded shall be ASTM A706 low alloy.
- B. Steel wire and welded wire fabric shall comply with ASTM A1064. Fabric shall be provided in flat sheets. Rolled fabric shall not be used.
- C. Reinforcement supports, including bolsters, chairs, spacers, and other devices for spacing, supporting, and fastening reinforcement in place shall be:
 - 1. Wire bar-type supports complying with CRSI recommendations, unless otherwise indicated.
 - 2. For slabs on grade, supports with sand plates, or horizontal runners where base material will not support chair legs.
 - 3. For exposed-to-view concrete surfaces or where the concrete surface will be exposed to weather or moisture, where legs of supports are in contact with forms, supports with either hot-dipped galvanized or plastic protected legs.
 - 4. When supports bear directly on the ground and it is not practical to use steel bar supports, precast concrete blocks may be used to support only the bottom lift of reinforcement. The precast blocks must be solid, be of an equal or higher strength than the concrete being placed, must provide adequate support to the reinforcement, and be of proper height to provide specified reinforcing cover. The use of face bricks, hollow concrete blocks, rocks, wood blocks, or other unapproved objects will not be permitted.

2.02 FABRICATION

- A. General:
 - 1. Fabricate reinforcing bars to conform to required shapes and dimensions with fabrication tolerances which comply with CRSI Manual.
 - 2. In case of fabricating errors, do not rebend or straighten reinforcement in a manner that will injure or weaken the material.
 - 3. Unless otherwise shown on the Drawings, all end hook dimensions shall conform with “ACI Standard Hooks.”
- B. Reinforcement with any of the following defects shall be deemed unacceptable and will not be permitted in the work:
 - 1. Bar lengths, depths, and bends exceeding specified fabrication tolerances.
 - 2. Bend or kinks not indicated on Drawings or final shop drawings.
 - 3. Bar with reduced cross section because of excessive rusting or other cause.

PART 3–EXECUTION

3.01 INSPECTION

- A. Examine the substrate, formwork, and the conditions under which concrete reinforcement is to be placed.

- B. Correct conditions detrimental to the proper and timely completion of the work.
- C. Do not proceed until unsatisfactory conditions have been corrected.

3.02 INSTALLATION

- A. General:
 - 1. Comply with the specified standards for details and methods of placing reinforcement and supports.
 - 2. Clean reinforcement to remove loose rust, mill scale, earth, and other materials that reduce or destroy bond with concrete.
- B. Placing Reinforcement:
 - 1. All reinforcing shall be placed in accordance with Contract Drawings and with shop drawings stamped and approved by ENGINEER.
 - 2. Position, support, and secure reinforcing against displacement by formwork, construction, or concrete placement operations.
 - 3. Support reinforcing by metal chairs, runners, bolsters, spacers, and hangers as needed.
 - 4. Unless otherwise shown on the Drawings, the reinforcement is to be so detailed and placed as to allow the following concrete protection:
 - a. Three inches of cover where the concrete is placed directly against ground.
 - b. Two inches of cover where the concrete is placed in forms but is to be exposed to weather, liquid, or the ground.
 - c. One-inch cover in slabs and walls not exposed to weather, liquid, or the ground.
 - d. One and one-half-inch cover in beams, girders, and columns not exposed to weather, liquid, or the ground. This cover applies to beam stirrups and column ties where applicable.
 - 5. Reinforcement shall be positioned within $\pm 3/8$ inch for members with depth to tension reinforcing from compression face less than or equal to 8 inches. Tolerance shall be $\pm 1/2$ inch for members with depth to tension reinforcing from compression face greater than 8 inches. Tolerance on dimension between adjacent bars in slab and wall reinforcing mats shall be 1 inch. Secure against displacement by anchoring at the supports and bar intersections with wire or clips.
 - 6. Bars shall be securely tied at all intersections, except where spacing is less than 1 foot in each direction when alternate intersections shall be tied. To avoid interference with embedded items, bar spacing may be varied slightly if acceptable to ENGINEER. Tack welding of reinforcing will not be permitted.
 - 7. Set wire ties so that twisted ends are directed away from exposed concrete surfaces.
 - 8. If reinforcing must be cut because of openings or embedded items in the concrete, additional reinforcing must be provided adjacent to the opening at least equal in cross sectional area to that reinforcing which was cut, and it shall extend a minimum of 36 bars diameters beyond the opening on each side or as shown on the Drawings. At sumps or depressions in slabs, bars shall be bent and/or extended under sumps or depressions.
 - 9. Wall reinforcing mats shall be secured in a vertical plane by providing clearance from forms with bar supports and by using Z-shaped bars at ± 4 feet on center wired between two mats of steel, spacing and staying both of them. Nails shall not be driven into the forms to support reinforcement and neither shall wire for this purpose come in contact with the forms. Alternate top transverse bars in slab shall be supported by individual bar chairs at approximately 3-foot 0-inch centers. Bottom longitudinal bars shall be supported by continuous bar chairs at approximately 4-foot 0-inch centers.

10. If carrier bars are to be used, CONTRACTOR shall provide reinforcing bars for this purpose in addition to the reinforcing called for by the Drawings and Specifications.
 11. Reinforcement bars used as grade pins shall not be tied to or used to support structural reinforcement. Grade pins shall either be completely removed or lowered to provide specified clear cover from the slab surfaces.
- C. Reinforcement Supports:
1. Strength and number of supports shall be sufficient to carry reinforcement.
 2. Do not place reinforcing bars more than 2 inches beyond the last leg of any continuous bar support.
 3. Do not use supports as bases for runways for concrete-conveying equipment and similar construction loads.
- D. Welded Wire Fabric:
1. Install welded wire fabric in as long of lengths as practicable.
 2. Lap adjoining pieces at least one full mesh.
 3. Fabric shall be supported with bar supports.
- E. Splices:
1. Provide standard reinforcement splices by lapping ends, placing bars in contact, and tightly wire tying.
 2. Lap splices in reinforcing shall be provided as shown on the Drawings. Where lap splice lengths are not shown on the Drawings, provide Class B, Category 1 lap splices in accordance with ACI 318.
 3. Adjacent splices of tangential bars in circular slabs and horizontal bars in circular walls shall be staggered a minimum of one full lap splice length or 3 feet, whichever is greater, unless otherwise shown. Stagger dimension shall be measured from center to center of lap splices.
 4. For circular walls, horizontal bar lap splices shall not coincide in vertical arrays more frequently than every third bar.
 5. Mechanical splices and threaded dowel bar inserts may be used where acceptable to ENGINEER.
- F. Embedded Items:
1. Allow other trades to install embedded items as necessary.
 2. Particularly after bottom layer of reinforcing is placed in slabs, allow electrical contractors to install conduit scheduled for encasement in slabs prior to placing upper layer of reinforcing.
- G. Minimum Reinforcing: Where reinforcing is not shown, provide a minimum of No. 4 at 8-inch centers each way in members 10 inches or less in thickness and No. 5 at 12-inch centers each way in each face in members greater than 10 inches thick.

END OF SECTION

SECTION 03 30 00
CAST-IN-PLACE CONCRETE

PART 1—GENERAL

1.01 SUMMARY

- A. Work Included:
 - 1. All cast-in-place concrete as shown except as noted otherwise.
 - 2. PVC and hydrophilic waterstops, expansion joint fillers, bonding agents, patching mortars, curing compounds, nonshrink grout, grout topping, floor sealer, and other related items and accessories.
- B. Related Sections and Divisions: Applicable provisions of Division 01 shall govern work in this section.

1.02 REFERENCES

- A. ACI 211.1—Standard Practice for Selecting Proportions for Normal, Heavyweight, and Mass Concrete.
- B. ACI 301—Specifications for Structural Concrete.
- C. ACI 304R—Guide for Measuring, Mixing, Transporting, and Placing Concrete.
- D. ACI 305R—Guide to Hot Weather Concreting.
- E. ACI 306R—Guide to Cold Weather Concreting.
- F. ACI 308—Specification for Curing Concrete.
- G. ACI 309—Guide for Consolidation of Concrete.
- H. ACI 318—Building Code Requirements for Structural Concrete and Commentary.
- I. ASTM C31—Standard Practice for Making and Curing Concrete Test Specimens in the Field.
- J. ASTM C33—Standard Specification for Concrete Aggregates.
- K. ASTM C39—Standard Test Method for Compressive Strength of Cylindrical Concrete Specimens.
- L. ASTM C40—Standard Test Method for Organic Impurities in Fine Aggregates for Concrete.
- M. ASTM C88—Standard Test Method for Soundness of Aggregates by Use of Sodium Sulfate or Magnesium Sulfate.
- N. ASTM C94—Standard Specification for Ready-Mixed Concrete.
- O. ASTM C143—Standard Test Method for Slump of Hydraulic-Cement Concrete.
- P. ASTM C150—Standard Specification for Portland Cement.

- Q. ASTM C156—Standard Test Method for Water Loss (from a Mortar Specimen) Through Liquid Membrane-Forming Curing Compounds for Concrete.
- R. ASTM C172—Standard Practice for Sampling Freshly Mixed Concrete.
- S. ASTM C231—Standard Test Method for Air Content of Freshly Mixed Concrete by the Pressure Method.
- T. ASTM C260—Standard Specification for Air-Entraining Admixtures for Concrete.
- U. ASTM C309—Standard Specification for Liquid Membrane-Forming Compounds for Curing Concrete.
- V. ASTM C494—Standard Specification for Chemical Admixtures for Concrete.
- W. ASTM C595—Standard Specification for Blended Hydraulic Cements.
- X. ASTM C618—Standard Specification for Coal Fly Ash and Raw or Calcined Natural Pozzolan for Use in Concrete.
- Y. ASTM C652—Standard Specification for Hollow Brick (Hollow Masonry Units Made From Clay or Shale).
- Z. ASTM D994—Standard Specification for Preformed Expansion Joint Filler for Concrete (Bituminous Type).
- AA. ASTM D1752—Standard Specification for Preformed Sponge Rubber Cork and Recycled PVC Expansion Joint Fillers for Concrete Paving and Structural Construction.

1.03 SUBMITTALS

- A. Submit shop drawings in accordance with Section 01 33 00—Submittals.
- B. Submit the following information:
 - 1. Gradation of fine and coarse aggregate—ASTM C33.
 - 2. Specific gravity and dry rodded density of each aggregate.
 - 3. Test of deleterious substances in fine and coarse aggregate—ASTM C33.
 - 4. Design mix of each individual concrete mix to be used.
 - 5. Previous test results or trial batch results with 7- and 28-day compressive strengths for each concrete mix proposed.
 - 6. Certified mill test results for cement identifying brand, type, and chemistry of cement to be used.
 - 7. Brand, type, principal ingredient, and amount of each admixture to be used.
- C. It is important that the above data be submitted to ENGINEER well in advance of anticipated concreting operations to avoid any delay in construction.

PART 2-PRODUCTS

2.01 CEMENT

- A. Cement shall be Portland cement Type I/II conforming to ASTM C150 or Portland limestone cement Type IL conforming to ASTM C595. All cement shall be the product of one reputable manufacturer and mill.
- B. Cement shall be stored in a dry, weathertight, properly ventilated structure with the floor raised not less than 1 foot above the ground.

2.02 FLY ASH

- A. All fly ash used as an admixture in Portland cement or Portland limestone cement concrete shall be Class C or F conforming to the requirements of ASTM C618.

2.03 AGGREGATE

- A. All aggregates shall be washed and shall consist of natural sand, gravel, or crushed rock and shall have clean, hard, durable, uncoated grains of strong minerals. The amounts of deleterious substances present in the fine and coarse aggregate expressed in percentages by weight shall not exceed the following:

Deleterious Substance	Aggregate	
	Fine	Coarse
Clay Lumps and Friable Particles	3.0	3.0
Coal and Lignite	0.5	0.5
Mineral finer than No. 200 sieve	3.0	
Soft Fragments	3.0	3.0
Chert*	---	5.0
Sum of Chert and Clay Lumps		5.0

* Material classified as chert and having a bulk specific gravity of less than 2.45. The percentage of chert shall be determined on the basis of the weight of chert in the sample retained on a 3/8-inch sieve divided by the weight of the total sample.

- B. The combined amount of all deleterious substances in an aggregate shall not exceed 5% of the weight of the aggregate.
- C. If requested by ENGINEER, sodium sulfate soundness tests (ASTM C88) shall be performed on the aggregate. When the aggregate is subjected to 5 cycles, the weight loss shall not exceed 12%. Samples of proposed aggregates shall be submitted to an independent laboratory for testing in advance of concrete work. All testing shall be performed in accordance with ASTM C33. Certified test results shall be submitted to ENGINEER confirming that aggregate complies with all stated specifications. Report shall identify source of aggregate and absorbed water.
- D. Fine aggregate shall be well-graded from coarse to fine and shall conform to the following requirements:

Percentage by Weight	
Passing 3/8-inch sieve	100
Passing No. 4 sieve	95-100
Passing No. 8 sieve	80-100
Passing No. 16 sieve	50-85
Passing No. 30 sieve	25-60
Passing No. 50 sieve	5-30
Passing No. 100 sieve	0-10

- E. Gradation of fine aggregate shall be reasonably uniform and not subject to the extreme percentages of gradation specified above. The fineness modulus shall be not less than 2.3 or more than 3.1, nor shall the fineness modulus of any sample vary by more than +0.20 from the fineness modulus of the representative sample used in proportioning the concrete.
- F. If requested by ENGINEER, fine aggregate shall be subjected to the color-metric test for organic impurities (ASTM C40) and shall not produce a color darker than Figure 1, unless they pass the mortar strength test. Aggregate producing color darker than Figure 2 shall not be used in any event.
- G. Coarse aggregate shall be well-graded from coarse to fine, and when tested by laboratory sieves having square openings, shall conform to the following requirements:

	Percentage by Weight Aggregate	
	3/4-Inch Stone	1 1/2-Inch Stone
Passing 2-inch sieve	---	100
Passing 1 1/2-inch sieve	---	90-100
Passing 1-inch sieve	100	20-55
Passing 3/4-inch sieve	90-100	0-15
Passing 3/8-inch sieve	20-55	0-5
Passing No. 4 sieve	0-10	---
Passing No. 8 sieve	0-5	---

- H. The 3/4-inch aggregate shall be used in concrete members no thinner than 4 inches and less than 10 inches thick. A blend of 3/4-inch and 1 1/2-inch aggregate shall be used in members 10 inches thick and thicker with the 3/4-inch aggregate comprising between 35% and 65% of the total course aggregate. When members thinner than 10 inches are placed monolithically with members thicker than 10 inches, the aggregate requirements for the thinner member shall apply.
- I. Aggregates must be allowed to drain for at least 12 hours before being used. The ground upon which aggregates are stored must be hard, firm, well-drained, and free from all vegetable matter. Various sizes of aggregates must be stored separately, and if they have become contaminated or merged with each other, they shall not be used.

2.04 WATER

- A. Water used in mixing concrete shall be clean and free from injurious amounts of oil, alkali, organic matter, or other deleterious substances.

2.05 ADMIXTURES

- A. Water Reducing Admixture shall be Master Pozzolith® 200 by Master Builders Solutions, Daracem 19 by Grace, or equal. Water reducing admixture shall conform to ASTM C494, Type A and Type F. Water reducing admixture shall not reduce durability, shall increase strength 10%, and shall not affect bleeding characteristics over reference mix.
- B. Air-Entraining Admixture shall be equal to MasterAir® AE 90 by Master Builders Solutions, Darex by Grace Construction Products, or equal. Air-entraining admixture shall conform to ASTM C260.
- C. No other admixture will be allowed without written approval of ENGINEER. All admixture shall be compatible with cement, aggregate, and water used.

2.06 PROPORTIONING

- A. The proportions of aggregate to cement shall be such as to produce a workable mixture that can be thoroughly compacted and that will work readily in the forms and around reinforcement without permitting materials to segregate or excess water to collect on the surfaces. The combined aggregates shall be such that when separated on the No. 4 sieve, the weight passing the sieve shall not be less than 30% nor greater than 50%.
- B. Concrete of various classes shall have the following maximum water/cement or water/(cement + fly ash) ratio minimum compressive strengths at 28 days and minimum cement and fly ash contents:

Class	Maximum Water/ Cement or Water/ (Cement+Fly Ash)	Minimum 28 Day Strength-Pounds per Square Inch	Cement Content-Pounds per Cubic Yard	Fly Ash- Pounds per Cubic Yard	
				Type C	Type F
A	0.45	4,000	564	---	---
A-FA	0.45	4,000	480	110	125

- C. Concrete topping for clarifier bottoms shall contain pea gravel, crushed stone, or other suitable coarse aggregate graded from 1/8 inch to 3/8 inch in addition to well-graded sand. Use six bags of Portland cement and 100 pounds of Class C fly ash per cubic yard. Not more than 35 gallons of mixing water per cubic yard, including free water in aggregate, shall be used. Minimum 28-day design strength shall be 4,000 psi. Provide similar mix with fibrous reinforcing added for concrete topping over precast plank.
- D. All concrete mixes shall be designed for a strength of 15% above that specified to allow for job variations. All mixes shall be designed in accordance with ACI 211.1 by a qualified concrete engineer or qualified laboratory technician. Required materials test data shall be submitted with design mixes for review and approval by ENGINEER. Mix computations shall be submitted if requested by ENGINEER.
- E. The slump for all concrete shall be 3 inches and concrete with a slump within the range of 2 to 3 1/2 inches will be acceptable, unless otherwise stated.
- F. A water-reducing admixture shall be used in all concrete. A qualified representative of the manufacturer shall be available to assist in proportioning the concrete, advise on the proper

addition of the admixture to the concrete, and advise on adjustments of concrete proportions to suit job conditions.

- G. An air-entraining admixture shall be used in all concrete except as noted. Air content shall be tested by the pressure method as outlined in ASTM C231 and shall be between 4% to 7% by volume. An air-entraining admixture is not required for concrete patching and for concrete floors, equipment pads, and supports in interior heated buildings where the concrete will be protected from freezing during and after construction.
- H. CONTRACTOR shall submit to ENGINEER concrete cylinder compressive strength results from previous projects for the same concrete mixes proposed on the current project. If this information is not available, one cubic yard trial batches of each individual mix proposed for use shall be made prior to use in the work. Four test cylinders shall be made for each trial batch, two to be tested at 7 days and two at 28 days. The trial batches shall be made preceding actual placement operations so that the results of the 7-day tests can be obtained. All costs for material, equipment, and labor incurred during design of concrete mixes shall be borne by CONTRACTOR.
- I. All aggregates shall be measured by weight. The concrete mixer is to be equipped with an automatic water-measuring device that can be adjusted to deliver the desired amount of water.

2.07 JOINT FILLER

- A. Expansion joints shall have standard 1/2-inch-thick cork expansion joint filler, W. R. Meadows, or equal, meeting ASTM D1752–Type II. Exceptions to this are expansion joints in exterior concrete walks and between concrete walks and other structures which shall be asphalt expansion joint filler, 1/2-inch-thick, Grace, W.R. Meadows, or equal, meeting ASTM D994.

2.08 BONDING AGENT

- A. Bonding agent for bonding new concrete to existing concrete at construction joints and for bonding concrete overlays to existing concrete shall be a liquid latex product meeting ASTM C1059, Type II. Acceptable products include Euroweld 2.0 by Euclid Chemical, Acrylic Bonding Agent J40 by Dayton Superior, or equal.

2.09 PATCHING ADDITIVE

- A. Acceptable manufacturers include MasterEmaco® A 660 by Master Builders Solutions, Sonocrete by Sonneborn Contech Co., or equal.

2.10 NONSHRINK GROUT

- A. Acceptable manufacturers include Dayton Superior, Master Builders Solutions, or equal. Grout shall be nonshrink, nonmetallic and shall achieve a strength of 7,500 psi in 28 days.

PART 3-EXECUTION

3.01 MIXING

- A. Ready-mixed concrete shall be batched, mixed, and delivered in accordance with ASTM C94 and ACI 304R. In general, concrete shall be mixed 50 revolutions at plant, 20 upon arrival at site, and 20 each time water is added; maximum of 110 revolutions at mixing speed. Concrete shall be delivered and discharged within 1 1/2 hours or before the drum has revolved 300 times after introduction of water to the cement and aggregates or the cement to the aggregates. Truck mixers shall be equipped with drum revolution counters. In no event shall concrete which has taken its initial set be allowed to be used. Retempering of concrete is not permitted.
- B. A representative of ENGINEER may be at the batching plant periodically to observe the batching and mixing.
- C. No water shall be added on the job unless required by CONTRACTOR and with the knowledge of ENGINEER; the amount of water, if added, shall be recorded on all copies of the delivery tickets. If water is added, CONTRACTOR shall verify that the required water-cement ratio is not exceeded.
- D. Concrete shall have a temperature not less than 60°F nor more than 80°F as delivered to the jobsite.
- E. With each load of concrete, CONTRACTOR shall obtain delivery tickets and shall make these tickets available for review by ENGINEER. Delivery tickets shall provide the following information:
 - 1. Date.
 - 2. Name of ready-mix concrete plant, job location, and CONTRACTOR.
 - 3. Type of cement and admixtures, if any.
 - 4. Specified cement content in sacks per cubic yard of concrete and approved concrete mix number or designation.
 - 5. Amount of concrete in load, in cubic yards.
 - 6. Water-cement ratio.
 - 7. Water added at job, if any.
 - 8. Truck number and time dispatched.
 - 9. Number of mixing drum revolutions.
- F. For job-mixed concrete, all concrete materials shall be mixed in a machine batch mixer for at least 1 1/2 minutes after all ingredients are in the mixer and shall continue until there is a uniform distribution of the materials and the mass is uniform in color and homogeneous. The mixer shall not be loaded beyond the capacity given by the manufacturer and shall be rotated at the speed recommended by the manufacturer. The mixer is to be provided with positive timing device that will positively prevent discharging the mixture until the specified mixing time has elapsed.

3.02 JOINTS

- A. CONTRACTOR shall place all joints as shown on the Drawings or specified herein. If acceptable to ENGINEER, CONTRACTOR may, at its own expense, place construction joints in addition to and at places other than those shown on the Drawings. Unless otherwise shown, all joints shall be straight, truly vertical or horizontal, and proper methods shall be employed to obtain this result.

- B. Where construction joints are not shown on the Drawings or specified elsewhere, CONTRACTOR shall provide construction joints in walls as follows:
 - 1. Vertical construction joints at 60 feet on center maximum but not more than 15 feet from corners or intersections.
 - 2. Horizontal construction joints at 18 feet on center maximum for walls 12 inches or more in thickness.
 - 3. Horizontal construction joints of 8 feet on center maximum for walls 10 inches or less in thickness.
- C. Immediately after completion of the first pour at a joint, the concrete surface, reinforcement, and waterstop projecting beyond the joint shall be thoroughly cleaned and laitance removed. The waterstops shall not be disturbed after the concrete in the first pour at a joint has set. Concrete around waterstops shall be thoroughly compacted by hand spading and vibrating. Immediately before the second pour, all extraneous matter shall be removed from the joint, the waterstop and steel cleaned, and the surface thoroughly wetted.
- D. Concrete at all joints shall have been in place at least 48 hours before abutting concrete is placed. At least two hours must elapse after depositing concrete in columns or walls before depositing in beams, girders, or slab supported thereon. Beams, girders, brackets, column capital, and haunches shall be considered as part of the floor system and shall be placed integrally therewith.

3.03 BONDING TO EXISTING CONCRETE

- A. When placing new concrete adjacent to existing concrete, the existing concrete shall be thoroughly roughened, cleaned, and saturated with water 24 hours before pouring new concrete. Existing concrete is defined as concrete more than six months old. At time of new pour, remove any standing water and apply bonding agent. Bonding agent shall be applied in accordance with manufacturer's recommendations.

3.04 PATCHING EXISTING CONCRETE

- A. When patching existing concrete, remove poor concrete until firm hard concrete is exposed; roughen and clean surface of the existing concrete, clean any exposed reinforcing bars, and pour new concrete. Concrete finish shall match existing concrete. New concrete shall be 4,000 psi 28-day strength mixed with patching additive, mixed according to manufacturer's instructions. Concrete shall not be air-entrained.

3.05 EMBEDDED ITEMS IN CONCRETE

- A. All sleeves, inserts, anchors, and embedded items required for adjoining work or for its support shall be placed prior to concreting.
- B. All contractors whose work is related to the concrete or must be supported by it shall be given ample notice and opportunity to introduce and/or furnish embedded items before the concrete is placed.
- C. Embedded items shall be positioned accurately and supported against displacement. Reinforcing bars shall clear embedded items a minimum of 2 inches.

3.06 PLACING CONCRETE

- A. Before placing concrete, all equipment, forms, ground, reinforcements, and other surfaces with which the concrete will come in contact are to be thoroughly cleaned of all debris, ice, and water. Ground shall be wetted prior to placement of concrete on it.

- B. After reinforcement is placed and before concrete is placed over it, ENGINEER shall be allowed sufficient time to observe the reinforcing.
- C. Unless otherwise authorized by ENGINEER, all concrete shall be placed in the presence of ENGINEER.
- D. Concrete shall be conveyed from the mixer to the place of final deposit as rapidly as practicable by methods that will prevent the segregation or loss of materials. Chuting for conveying purposes must be accomplished in such a manner as to prevent segregation or loss of materials. Receiving hoppers shall be installed at the chute discharge and at no point in its travel from the mixer to place of final deposit shall the concrete pass through a free vertical drop of more than 3 feet. Elephant trunks or tremies shall be used in all wall pours to prevent coating of forms and reinforcing bars.
- E. Care shall be taken to avoid an excess of water on the concrete surface. Excess water shall be drained or otherwise removed from the surface. Dry cement or a mixture of cement and sand shall not be sprinkled directly on the surface to absorb water.
- F. Concrete in wall and beam pours shall be deposited in approximately horizontal layers not to exceed 18 inches in thickness. Each layer shall be well worked into the preceding layer while both layers are still soft.
- G. Concrete shall be deposited as nearly as practicable in its final position to avoid segregation from rehandling or flowing. The maximum allowable lateral movement of the concrete after being deposited is 3 feet. Once concreting is started, it shall be carried on as a continuous operation until the placing of the section or panel is completed.
- H. All concrete shall be placed with the aid of mechanical vibrating equipment in accordance with ACI 309. In congested areas, vibration shall be supplemented by hand spading adjacent to the forms. Vibration should secure the desired results within 5 to 15 seconds at intervals of 18 inches apart maximum. The vibrator shall penetrate the preceding layer of concrete. Vibrators shall have a frequency of not less than 10,000 impulses per minute when in operation submerged in concrete.
- I. A sufficient number of spare vibrators shall be kept in ready reserve to provide adequate vibration in case of breakdown of those in use.
- J. In placing concrete in beams where it is intended to be continuous and monolithic with the slab above, a delay to provide for settlement of the deep concrete shall be scheduled before placing the upper concrete in the slab. The length of delay shall be as long as possible and still permit the revibration of the deep concrete.
- K. Concrete is not to be placed under water. A suitable means shall be provided for lowering the water level below surfaces upon which concrete is to be placed. This may require excavating approximately 12 inches below the bottom of the concrete surface and refilling with gravel and compacting. The groundwater shall not be allowed to rise to the bottom of the concrete until 24 hours after the concrete pour has been completed. Water shall not be allowed to fall upon or run across the concrete during this period.
- L. No extra payment will be allowed for dewatering, undercutting, and gravel fill.

3.07 MOIST CURING

- A. All concrete shall be maintained in a moist condition for at least 7 days after being deposited except that for high-early strength concrete, a 3-day period will be sufficient. Moist curing shall be accomplished by one of the following methods:
1. Wood forms left in place and kept wet at all times. If wood forms are not going to be kept wet or if metal forms are used, they shall be removed as soon as practicable and other methods of moist curing shall be started without delay.
 2. Use of a curing compound conforming to ASTM C309, Type I as approved by ENGINEER. Curing compound shall be applied at a uniform rate as indicated by the manufacturer sufficient to comply with the requirements of the test water retention of ASTM C156. Curing compound applied to vertical concrete surfaces after forms are removed shall be specially adapted to provide required coverage on the vertical surface. On nonformed surfaces, the curing compound shall be applied immediately after the disappearance of the water sheen after finishing of the concrete. Curing compound shall not be used on concrete surfaces that are to be painted, receive ceramic tile or resilient flooring, or be waterproofed. The curing compound for potable water structures shall be certified per NSF/ANSI-61. Care shall be taken not to get curing compound on construction joints, reinforcing steel, and other surfaces against which new concrete will be poured.
 3. Use of plastic film. Plastic film shall have a minimum thickness of 4 mils. It shall be placed over the wet surface of the fresh concrete as soon as possible without marring the surface and shall be weighted so that it remains in contact with all exposed surfaces of the concrete. All joints and edges shall be lapped and weighted. Any tears in the film shall be immediately repaired.
 4. Application of wet coverings weighing 9 ounces per square yard such as burlap, cotton mats, or other moisture-retaining fabrics. The covering system shall include two layers and shall be kept continuously moist so that a film of water remains on the concrete surface throughout the curing period.
 5. Use of an approved waterproof curing paper. Edges of adjacent sheets shall be overlapped several inches and tightly sealed.
 6. Ponding of water or continuous sprinkling of water is permitted. Sprinkling at intervals will not be permitted.
 7. Construction joints shall be moist cured by one of the methods listed above except by Method "2."
- B. The use of moist earth, sand, hay, or another method that may discolor hardened concrete will not be permitted.

3.08 HOT WEATHER CONCRETING

- A. When the atmospheric temperature exceeds 80°F during concrete placement, this section and ACI 305 shall apply in addition to all other sections of the specifications.
- B. The temperature of the delivered concrete shall not exceed 85°F.
- C. Care shall be exercised to keep mixing time and elapsed time between mixing and placement at a minimum. Ready-mix trucks shall be dispatched so as to avoid delay in concrete placement, and the work shall be organized to use the concrete promptly after arrival at the jobsite.
- D. The subgrade, forms, and reinforcing shall be sprinkled with cool water just prior to placement of concrete. Prior to placing concrete, there shall be no standing water or puddles on the subgrade.

- E. If approved by ENGINEER, an admixture for retarding the setting of the concrete may be used.
- F. Exposed concrete surfaces shall be carefully protected from drying. Continuous water curing is preferred. Curing compounds shall be white pigmented.

3.09 COLD WEATHER CONCRETING

- A. Conditions of this section shall apply, in addition to all other sections of the specifications, when placing concrete in cold weather. Cold weather is defined as a period when, for more than three successive days, the average daily temperature drops below 40°F. When temperatures above 50°F occur during more than half of any 24-hour period, the period will no longer be regarded as cold weather. The average daily temperature is the average of the highest and lowest temperature during the period from midnight to midnight. Cold weather concreting shall conform to all requirements of ACI 306.1, except as modified by the requirements of these specifications.
- B. Detailed procedures for the production, placement, protection, curing, and temperature monitoring of concrete during cold weather shall be submitted to ENGINEER. Cold weather concreting shall not begin until these procedures have been reviewed for conformance with ACI 306.1.
- C. All concrete materials, forms, ground, mixing equipment, and other surfaces with which the concrete is to come in contact shall be free from frost, and the temperature of contact surfaces shall be 35°F or above. Ground upon which concrete is to be placed shall not be frozen at any depth.
- D. The mixing water and aggregates shall be heated and when entering the mixer shall have temperatures not exceeding 175°F and 80°F, respectively. Concrete temperature as mixed shall not exceed 80°F and shall typically be between 55°F and 70°F. Concrete, when placed in the forms, shall have a temperature of not less than 50°F.
- E. Freshly placed concrete shall be protected by adequate covering, insulating, or housing and heating. If heating is used, ambient temperature inside the housing shall be maintained at a minimum of 70°F for 3 days or 50°F for 5 days. The maximum ambient temperature during curing shall not exceed 80°F. If insulating methods are used, recommendations contained in ACI 306R shall be followed. Surface temperature shall be maintained at 50°F for 7 days. After the curing period, the temperature of the concrete shall be reduced uniformly at a rate not to exceed 40°F per 24 hours until outside air temperature is reached. Heating of enclosure shall continue if it is anticipated that the outside air temperature will drop more than 20°F in the next 24 hours. The concrete temperature shall be obtained by attaching a thermometer provided by CONTRACTOR to the concrete surface. Concrete shall be kept moist.
- F. If heating is used, the housing shall be constructed weathertight and shall be constructed in a manner that will provide uniform air circulation and air temperatures over the complete concrete area that is being cured. Special attention shall be given to the edges and ends of a concrete pour with the housing extending at least 5 feet beyond any concrete surface being protected. The housing shall be in place and heat applied within 2 hours after concrete placement.
- G. Heating may be by steam or hot air. Heaters shall be vented to outside of the housing. Open burning salamanders will not be permitted. Heating devices shall not be placed so close to the concrete as to cause rapid drying or discoloration from smoke.

- H. If heating is used, CONTRACTOR shall provide sufficient 24-hour inspection of the heaters to provide compliance with the above-specified temperature requirements during the curing period. CONTRACTOR shall provide maximum-minimum thermometers for ENGINEER's use.
- I. The use of calcium chloride, salts, or other chemical admixtures for the prevention of freezing is prohibited.
- J. Salts or other deleterious materials shall not be used on temporary or permanent structures above concrete surfaces that are being placed, finished, or cured.

3.10 FINISHING

- A. Flat Work:
 - 1. Broom or Belt Finish: Immediately after concrete has received a floated finish, give the concrete surface a coarse transverse scored texture by drawing a broom or burlap belt across the surface.
 - 2. The above finishes shall be used in the following locations: Broom or Belt Finish—Exterior slabs.
- B. Formed Surfaces:
 - 1. Within 2 days after removing forms and prior to application of a curing compound, all concrete surfaces shall be observed and any poor joints, voids, stone pockets, or other defective areas shall be patched at once before the concrete is thoroughly dry. Defective areas shall be chipped away to remove all loose and partially bonded aggregate. The area shall be thoroughly wetted and filled with as dry as practical mortar mix placed to slightly overfill the recess. Mortar shall include a bonding agent. After partial set has taken place, the excess mortar shall be removed flush with the surface on the concrete using a wood float. All patching shall be cured, protected, and covered as specified for concrete. All cracks, leaks, or moist spots that appear shall be repaired. No extra compensation will be allowed CONTRACTOR for such work.
 - 2. The exterior or removal portion of nonremovable ties shall be removed with the use of a special tool designed for this purpose. Cutting or chipping of concrete to permit removal of exterior portion will not be permitted.
 - 3. For nonremovable ties, tie rod holes left by the removal of the exterior portion of the tie and cone shall be thoroughly wetted and filled by ramming with as dry as practical mortar mix in such a manner such that it completely fills the hole. Mortar shall include a bonding agent. All patching shall be cured, protected, and covered as specified for concrete. The holes are to be filled immediately after removal of the exterior portion of the tie.
 - 4. All finished or formed surfaces shall conform accurately to the shape, alignment, grades, and sections as shown or prescribed by ENGINEER. All surfaces shall be free from fins, bulges, ridges, offsets, honeycombing, or roughness. All sharp angles, where required, shall be rounded or beveled. The surface of the concrete shall be given the following finish immediately after form stripping: Finish A shall be the finish for surfaces that may be left as they come from the forms, except that tie holes shall be plugged and defects greater than 1/2 inch in any dimension shall be repaired. Finish A shall be provided for surfaces to be buried or covered by other construction such as masonry veneer.
- C. All precautions shall be taken to protect the concrete from stains or abrasions, and any such damage shall be removed or repaired under this Contract.

3.11 LOADING OF CONCRETE STRUCTURES

- A. No concrete structure or portion thereof shall be loaded with its design load until the concrete has obtained its specified 28-day compressive strength. This shall include but not be limited to vertical live load, equipment loading, water loading, groundwater loading, and backfill load. Concrete strength at time of loading shall be determined by testing field-cured concrete cylinders.
- B. Extreme care shall be taken so that construction loads do not exceed design loading of the structure.

3.12 NONSHRINK GROUT

- A. Nonshrink, nonmetallic grout shall be used for filling recesses and pockets left for equipment installation and for setting of base plates. The material used shall be approved by ENGINEER. Store, mix, and place the nonshrinking compound as recommended by the manufacturer. The minimum compressive strength shall be 5,000 psi at age 7 days and 7,500 psi at age 28 days.

3.13 TESTING AND SAMPLING

- A. The following tests of fresh concrete shall be performed by CONTRACTOR. CONTRACTOR shall prepare, protect, transport, and have tested all cylinders at its expense.
 - 1. Sampling of concrete for slump tests, air tests, temperature tests, and for making concrete test cylinders shall be performed in accordance with ASTM C172.
 - 2. Cylinders:
 - a. Three test cylinders shall be made for each pour less than 25 cubic yards, four test cylinders shall be made for each pour between 25 and 100 cubic yards, and eight test cylinders shall be made for each pour in excess of 100 cubic yards. Each concrete mix shall be represented by at least four cylinders for the entire job. Concrete for cylinders shall be collected near the middle of the load and/or as requested by ENGINEER.
 - b. Cylinders shall be made and tested in accordance with ASTM C31 and ASTM C39, respectively. The cylinders must be kept moist and at temperatures between 60°F and 80°F and shall remain undisturbed and stored in a location free from vibration. In hot weather, the cylinders shall be covered with wet burlap and stored in a shaded area. It is CONTRACTOR's responsibility to provide a suitable protected location for storing cylinders on the jobsite.
 - c. After 24 hours, the cylinders shall be transferred to an independent testing laboratory acceptable to OWNER. The cylinders shall be packed in sawdust or other cushioning material for transit to avoid any bumping or jarring of the cylinders.
 - d. Cylinders shall be broken at 7 and 28 days or as requested by ENGINEER. Test results shall be transmitted immediately and directly to ENGINEER and OWNER. Test data shall include date and location of pour and concrete mix used.
 - 3. Slump Test: CONTRACTOR shall make one slump test near the beginning of all pours with two tests being made for all pours in excess of 25 yards or as requested by ENGINEER. Slump tests shall conform to ASTM C143.
 - 4. Air Test:
 - a. When air-entrained concrete is used, the air content shall be checked by CONTRACTOR near the beginning of all pours with at least two checks being made for all pours in excess of 25 cubic yards, or as requested by ENGINEER.
 - b. The air contents shall be checked using the pressure method in accordance with ASTM C231. The pocket-sized alcohol air indicator shall not be used unless it is first used in conjunction with the pressure method test.

- B. All costs of additional testing and sampling of fresh or hardened concrete needed because of suspected or actual violation of the specifications shall be borne by CONTRACTOR.

3.14 RECORDS

- A. A record is to be kept of all concrete work. The record shall include the date, location of pour, concrete mix, slump, air content, test cylinder identification, concrete temperature, and ambient air temperature. In addition, for cold weather concreting the record shall include the daily maximum-minimum thermometer readings of all thermometers during the entire curing period for all concrete pours. The Resident Project Representative will keep this record, and CONTRACTOR shall assist in obtaining needed information.

3.15 CONCRETE REMOVAL AND PATCHING

- A. All areas disturbed as a result of concrete removal or repair shall be patched as specified in Bonding to Existing Concrete.

END OF SECTION

SECTION 05 50 00
METAL FABRICATIONS

PART 1–GENERAL

1.01 SUMMARY

- A. Work Included: Shop-Fabricated Carbon Steel, Stainless Steel, and Aluminum Items.
- B. Related Sections and Divisions: Applicable provisions of Division 01 shall govern work in this section.

1.02 REFERENCES

- A. ASTM A36–Carbon Structural Steel.
- B. ASTM A53–Pipe, Steel, Black and Hot-Dipped, Zinc-Coated, Welded and Seamless.
- C. ASTM A123–Zinc (Hot-Dip Galvanized) Coatings on Iron and Steel Products.
- D. ASTM A143–Practice for Safeguarding Against Embrittlement of Hot-Dipped Galvanized Structural Steel Products and Procedure for Detecting Embrittlement.
- E. ASTM A153–Zinc Coating (Hot-Dip) on Iron and Steel Hardware.
- F. ASTM A240–Standard Specification for Chromium and Chromium Nickel Stainless Steel Plate, Sheet, and Strip for Pressure Vessels and for General Applications.
- G. ASTM A276–Stainless Steel Bars and Shapes.
- H. ASTM A307–Carbon Steel Bolts, Studs, and Threaded Rod 60,000 psi Tensile Strength.
- I. ASTM A384–Practice for Safeguarding Against Warpage and Distortion During Hot-Dip Galvanizing of Steel Assemblies.
- J. ASTM A385–Practice for Providing High-Quality Zinc Coatings (Hot-Dip).
- K. ASTM A500–Standard Specification for Cold-Formed Welded and Seamless Carbon Steel Structural Tubing in Rounds and Shapes.
- L. ASTM A780–Repair of Damaged and Uncoated Areas of Hot-Dip Galvanized Coatings.
- M. ASTM A992–Structural Steel Shapes.
- N. ASTM A1008–Standard Specification for Steel, Sheet, Cold-Rolled, Carbon, Structural, High-Strength Low-Alloy, High-Strength Low-Alloy with Improved Formability, Solution Hardened, and Bake Hardenable.

- O. ASTM A1011—Standard Specification for Steel, Sheet and Strip, Hot-Rolled, Carbon, Structural, High-Strength Low-Alloy, High-Strength Low-Alloy with Improved Formability, and Ultra-High Strength.
- P. ASTM B209—Aluminum and Aluminum-Alloy Sheet and Plate.
- Q. ASTM B211—Aluminum and Aluminum-Alloy Rolled or Cold Finished Bar, Rod, and Wire.
- R. ASTM B221—Aluminum and-Alloy Extruded Bars, Rods, Wire, Profiles and Tubes.
- S. AWS A2.0—Standard Symbols for Welding, Brazing, and Nondestructive Examination.
- T. AWS A5.4—Stainless Steel Electrodes for Shielded Metal Arc Welding.
- U. AWS D1.1—Structural Welding Code—Steel.
- V. AWS D1.2—Structural Welding Code—Aluminum.
- W. AWS D1.6—Structural Welding Code—Stainless Steel.
- X. ASTM F593—Standard Specifications for Stainless Steel Bolts, Hex Cap Screws, and Studs.
- Y. ASTM F594—Standard Specification for Stainless Steel Nuts.

1.03 DESIGN REQUIREMENTS

- A. All fabrications shall meet applicable code requirements including OSHA.

1.04 SUBMITTALS FOR REVIEW

- A. Comply with pertinent provisions of Section 01 33 00—Submittals.
- B. Shop Drawings: Indicate profiles, sizes, connection attachments, reinforcing, anchorage, size and type of fasteners, and accessories. Include erection drawings, sections, elevations, and details where applicable.
- C. Mill Test Reports: Submit indicating structural strength and composition.
- D. Indicate welded connections using standard AWS A2.0 welding symbols. Indicate net weld lengths.

1.05 QUALITY ASSURANCE

- A. Fabricate steel members in accordance with AISC Code of Standard Practice.
- B. Welders Certificates: Certify welders employed on the work, verifying AWS qualification within the previous 12 months.

1.06 QUALIFICATIONS

- A. Qualify welding processes and welding operators in accordance with AWS *Standard Qualifications Procedures*.

1.07 DELIVERY, STORAGE, AND HANDLING

- A. Deliver all materials to job site properly marked to identify the structure for which it is intended and at such intervals to allow uninterrupted progress of the work. Marking shall correspond to markings indicated on the shop drawings.
- B. Store all members off the ground using pallets, platforms, or other supports.
- C. Do not store materials on the structure in a manner that might cause distortion or damage to the members of the supporting structures.
- D. In the event of damage, immediately make all repairs and replacements necessary at no additional cost to OWNER.

PART 2–PRODUCTS

2.01 MATERIALS–CARBON STEEL

- A. Steel Sections:
 - 1. ASTM A36 (channels, angles, plates).
 - 2. ASTM A992 (wide flange sections).
 - 3. Pipe: ASTM A53, Grade B.
 - 4. Tubes: ASTM A500, Grade B.
 - 5. Silicon content of steel members to be hot-dipped galvanized shall be in the range of 0 to 0.04%. Submit mill test reports confirming compliance.
- B. Sheet Steel: ASTM A1011.
- C. Plain Washers: Round carbon steel complying with FS FF-W-92.
- D. Bolts, Threaded Rods, and Nuts: ASTM A307 Grade A, or galvanized to ASTM A153 for galvanized components for exterior use and where built into exterior walls.
- E. Lock Washers: Helical spring-type carbon steel complying with FS FF-W-84.
- F. Welding Electrodes: Comply with AWS D1.1. E70XX electrodes for carbon steel. For ASTM A992 steel and any other steel with 50 ksi or greater yield strength, use only E7018 or other E70XX electrodes specifically permitted by AWS D1.1.
- G. Select fasteners for the type, grade, and class required.

2.02 MATERIALS–STAINLESS STEEL

- A. Unless otherwise noted, all stainless steel bars and shapes shall meet the requirements of ASTM A276 and shall be Type 316L.

- B. Unless otherwise noted, all stainless steel bolts shall meet the requirements of ASTM F593 and shall be Type 316L.
- C. Unless otherwise noted, all stainless steel nuts shall meet the requirements of ASTM F594 and shall be Type 316L.
- D. If components are not available in Type 316L, other 300 Series type shall be used as approved by ENGINEER.
- E. Welding Electrodes:
 - 1. Comply with AWS D1.6.
 - 2. Use ER316L electrodes for 316L stainless steel.
 - 3. Use ER308L electrodes for 304L stainless steel.

2.03 MATERIALS–ALUMINUM

- A. Extruded Aluminum: ASTM B221, Alloy 6061, Temper T6.
- B. Sheet Aluminum: ASTM B209, Alloy 3005.
- C. Aluminum-Alloy Bars: ASTM B211, Alloy 6061, Temper T6.
- D. Bolts, Nuts, and Washers: Steel, galvanized to ASTM A153.
- E. Welding Materials: AWS D1.2; type required for materials being welded.

2.04 FABRICATION

- A. Fabrication and Assembly:
 - 1. Fabricate items of structural steel in accordance with AISC Specifications and as indicated on the approved shop drawings.
 - 2. Properly mark and match-mark materials for field assembly and for identification as to structure and site for which intended.
 - 3. Fabricate for delivery sequence which will expedite erection and minimize field handling of materials.
 - 4. Where finishing is required, complete the assembly, including welding of units, before start of finishing operation.
 - 5. Provide finish surfaces of members exposed in the final structure free of markings, burrs, and other defects.
- B. Connections:
 - 1. Bolts and washers of all types and sizes shall be provided for completion of all field erection.
 - 2. Comply with AWS Code for procedures, appearance, and quality of welds used in correcting welded work.
 - 3. Assemble and weld built-up sections to produce true alignment of axes without warp.
 - 4. Welding shall be done by the shielded arc process.
 - 5. All welds shall be chipped, ground smooth, and primed immediately after fabrication.

- C. Workmanship:
1. Use materials of size and thickness shown or, if not shown, of size and thickness to produce strength and durability in the finished product.
 2. Work to dimensions shown or accepted on the shop drawings using proven details of fabrication and support.
 3. Form exposed work true to line and level, with accurate angles and surfaces, and with straight sharp edges.
 4. Form bent metal corners to smallest radius possible without causing grain separation or otherwise impairing works.
 5. Cap all open ends of pipe and structural tubing.
 6. Weld corners and seams continuously, complying with AWS recommendations. At exposed connections, grind exposed welds smooth and flush; match and blend with adjoining surfaces.
 7. Provide for anchorage of the type shown. Coordinate with supporting structures. Fabricate and space the anchoring devices to provide adequate support for intended use.
 8. Cut, reinforce, drill, and tap miscellaneous metal work as indicated to receive hardware and similar items.

2.05 FINISHES

- A. Carbon steel surfaces shall be prepared by abrasive blasting to SSPC-SP10 as specified in Section 09 91 00–Painting.
- B. Do not prime surfaces where galvanizing or field welding is required.
- C. Immediately after surface preparation, prime paint carbon steel items with one coat in accordance with manufacturer’s instructions and Section 09 91 00–Painting.
- D. Structural Steel Members: Galvanize after fabrication to the requirements in this section and ASTM A123.
- E. Surfaces that will be inaccessible after assembly or erection shall be finish painted prior to assembly or erection.
- F. Galvanizing:
1. All items, except piping designated to be galvanized, shall be hot-dipped galvanized in accordance with ASTM Specification A123 and A153. Piping shall be hot-dipped galvanized in accordance with ASTM A53. Furnish a Certificate of Compliance stating that the galvanizing complies with ASTM Specifications and Standards and all other applicable requirements specified herein.
 2. Fabrication of items to be galvanized shall be in accordance with ASTM A143, A384, and A385. Structural steel shall be fabricated generally in accordance with Class 1 guidelines as shown in *Recommended Details for Galvanized Structures* as published by the American Hot Dip Galvanizer’s Association, Inc.
 3. Galvanized items shall be handled, transported, and stored to prevent damage or staining to the coating. Maintain adequate ventilation and continuous drainage.
 4. Silicon content for steel to be hot-dipped galvanized shall be in the range of 0 to 0.04%.
 5. Steel work shall be precleaned utilizing a caustic bath, acid pickle and flux, or shall be blast cleaned and fluxed. In either case, all surface contaminants and coatings shall be removed.

6. All welding shall be performed in accordance with the American Welding Society publication D19.0-72, *Welding Zinc Coated Steel*. All uncoated weld areas shall be touched up.
- G. Aluminum shall have a mill finish unless otherwise specified. Any aluminum in contact with concrete or dissimilar metal shall be coated with multiple coats of bituminous paint, minimum 10 mils dry.

PART 3–EXECUTION

3.01 EXAMINATION

- A. Correct conditions detrimental to the proper and timely completion of the work.
- B. Do not proceed until unsatisfactory conditions have been corrected.

3.02 PREPARATION

- A. Furnish setting drawings, diagrams, templates, instructions, and directions for installation of anchorages such as concrete inserts, anchor bolts, and miscellaneous items having integral anchors which are to be embedded in concrete construction.
- B. Coordinate delivery of such items to project.
- C. Clean and strip primed steel items to bare metal where site welding is required.

3.03 INSTALLATION

- A. Setting Precast Anchorages:
 1. Clean bearing surfaces free from bond-reducing materials, and roughen to improve bond to surfaces. Clean the bottom surface of bearing plates.
 2. After the bearing members have been positioned and plumbed, tighten and anchor bolts. Do not remove wedges or shims, but if protruding, cut off flush with the edge of the bearing plate before packing with grout.
 3. Pack grout solidly between bearing surfaces and plates so that no voids remain.
- B. Fastening to In-Place Construction: Provide anchorage devices and fasteners where necessary for securing miscellaneous metal fabrications to in-place construction including threaded fasteners for concrete inserts, toggle bolts, through bolts, lag bolts, wood screws, and other connectors.
- C. Cutting, Fitting, and Placement:
 1. Perform cutting, drilling, and fitting for installation of miscellaneous metal fabrications.
 2. Set work accurately in location, alignment, and elevation and make plumb, level, true, and free from rack measured from established lines and levels.
 3. Fit exposed connections accurately together to form tight hairline joints.
 4. Weld connections that are not to be left as exposed joints, grind joints smooth, and touchup shop paint coat or galvanizing repair.

3.04 FIELD WELDING

- A. Comply with AWS Code for procedures of manual shielded metal arc welding (steel, stainless steel) and gas metal arc welding (aluminum), appearance and quality of weld made, and methods in correcting welding work.

3.05 TOUCH-UP PAINTING

- A. Immediately after erection, clean field welds, bolted connections, and abraded areas of shop paint, and paint exposed areas with same material as used for shop painting in accordance with Section 09 91 00–Painting.

3.06 GALVANIZING REPAIR

- A. Areas damaged by welding, flame-cutting, or during handling, transport, or erection shall be repaired by one of the following methods whenever damage exceeds 3/16 inch in width.
 - 1. Cold Galvanizing Compound:
 - a. Surfaces to be reconditioned with zinc-rich paint shall be clean, dry, and free of oil, grease, and corrosion products.
 - b. Areas to be repaired shall be power disc-sanded to bright metal. So that a smooth reconditioned coating can be effected, surface preparation shall extend into the undamaged galvanized coating.
 - c. Touch-up paint shall be an organic cold-galvanized compound having a minimum of 94% zinc dust in the dry film.
 - d. The paint shall be spray- or brush-applied in multiple coats until a dry film thickness of 8 mils minimum has been achieved. A finish coat of aluminum paint shall be applied to provide a color blend with the surrounding galvanizing.
 - e. Coating thickness shall be verified by measurements with a magnetic or electromagnetic gauge.
 - 2. Zinc-Based Solder:
 - a. Surfaces to be reconditioned with zinc-based solder shall be clean, dry, and free of oil, grease, and corrosion products.
 - b. Areas to be repaired shall be wire-brushed.
 - c. Heat shall be applied slowly and broadly close to but not directly onto the area to be repaired. The zinc-based solder rod shall be rubbed onto the heated metal until the rod begins to melt. A flexible blade or wire brush shall be used to spread the melt over the area to be covered. The zinc-based solder shall be applied in a minimum thickness of 2 mils.
 - d. Coating thickness shall be verified by measurements with a magnetic or electromagnetic gauge.

3.07 SCHEDULE

- A. The following schedule is a list of principal items only. Refer to Drawing details for items not specifically scheduled.
- B. Guard Posts: Steel pipe, concrete-filled, crowned cap, as detailed-galvanized and field finish paint in accordance with Division 09.

END OF SECTION

Section 05 50 00-7

1667.011/2-2026

SECTION 05 56 00

ANCHOR BOLTS AND POST-INSTALLED ANCHORS

PART 1–GENERAL

1.01 SUMMARY

- A. Work Included: Anchor Bolts, Expansion Bolts, Adhesive Anchors, and Screw Anchors.
- B. Related Sections and Divisions: Applicable provisions of Division 01 shall govern work in this section.

1.02 REFERENCES

- A. ASTM A36/A36M–Standard Specification for Carbon Structural Steel.
- B. ASTM F1554–Anchor Bolts, Steel, 36, 55, and 105 ksi yield strength.
- C. ICC-ES International Code Council–Evaluation Service.
- D. AC 193–Acceptance Criteria for Mechanical Anchors in Concrete Elements.
- E. AC 308–Acceptance Criteria for Post-Installed Adhesive Anchors in Concrete.
- F. ACI 355.2–Qualification of Post-Installed Mechanical Anchors in Concrete and Commentary.
- G. ACI 355.4–Qualification of Post-Installed Adhesive Anchors in Concrete and Commentary.

PART 2–PRODUCTS

2.01 GENERAL

- A. Unless indicated otherwise on the Drawings or specified, use the following bolt material for the various installation situations:
 - 1. Stainless Steel: For items not to be painted. Also for anchoring equipment, unless otherwise specified.
 - 2. Steel: In other locations in contact with items to be painted.

2.02 ANCHOR BOLTS

- A. Anchor bolts complete with washers and nuts shall be fabricated as shown or as specified by the equipment manufacturer and unless otherwise indicated shall be hot-dip galvanized carbon steel or 316 stainless steel. Anchor bolts shall, as a minimum, conform to the requirements of ASTM F1554-Grade 36.
- B. Stainless steel anchor bolts shall be used in contact with aluminum and other items not to be painted. Galvanized anchor bolts shall be used elsewhere.

2.03 EXPANSION BOLTS

- A. Expansion bolts shall be KWIK Bolt TZ2 by Hilti, Inc., Power-Stud+ SD2, SD4, or SD6 by DeWalt, Strong-Bolt 2 by Simpson Strong-Tie Anchor Systems, or approved equal.
- B. All expansion bolts shall comply with the 2021 International Building Code, AC 193, and ACI 355.2. They shall be ICC-ES approved for use in cracked and uncracked concrete.
- C. Expansion bolts will not be permitted as substitutes for embedded anchor bolts except with the prior written acceptance of ENGINEER or where otherwise specifically called for.

2.04 ADHESIVE ANCHORS

- A. Adhesive anchors shall be HIT-HY 200 V3 or HIT-RE 500 V3+ by Hilti, Inc., Red Head C6+ or Red Head A7+ by ITW, Pure 110+ or AC200+ by DeWalt, Set-3G by Simpson Strong-Tie Anchor Systems, or approved equal.
- B. All adhesive anchors shall comply with the 2021 International Building Code, AC 308, and ACI 355.4. They shall be ICC-ES approved for use in cracked and uncracked concrete.

2.05 SCREW ANCHORS

- A. Screw anchors shall be KWIK HUS-EZ by Hilti, Inc., Screw-Bolt+ by DeWalt, Titen HD by Simpson Strong-Tie Anchor Systems, or approved equal.
- B. All screw anchors shall comply with the 2021 International Building Code. They shall be ICC-ES approved for use in cracked and uncracked concrete.

PART 3-EXECUTION

3.01 ANCHOR BOLTS

- A. Anchor bolts for structural members shall be located as shown and specified.
- B. Anchor bolts for mechanical equipment shall have embedment length, edge distances, and spacing as required by the equipment manufacturer.
- C. All dirt or foreign materials shall be removed prior to embedding into concrete. After anchor bolts have been embedded, their threads shall be protected by grease and by installing the nuts or by other means until the time of installation of the equipment or metal work.

3.02 EXPANSION BOLTS

- A. Unless otherwise noted on the Drawings, expansion bolt edge distance and spacing shall be in accordance with manufacturer's printed installation instructions.
- B. Bolt embedment shall at least equal 6-bolt diameters.
- C. Installation procedures shall be in accordance with the manufacturer's printed installation instructions.

- D. Where location of bolts is adjustable, reinforcing steel shall be located prior to drilling holes and bolts shall be located to clear reinforcing steel.

3.03 ADHESIVE ANCHORS

- A. At locations shown on the Drawings, reinforcing bars or threaded rod shall be provided in existing concrete by drilling holes, injecting epoxy adhesive, and inserting the reinforcing bar.
- B. All existing surfaces to receive adhesive anchors, including the entire area in contact with the new concrete, shall be cleaned and roughened to amplitude of 1/4 inch.
- C. Installation procedures shall be in accordance with the manufacturer's printed installation instructions.
- D. Adhesive anchors shall be installed in concrete having a minimum age of 21 days at the time of installation.
- E. Where location of anchors is adjustable, reinforcing steel shall be located prior to drilling holes and anchors shall be located to clear reinforcing steel.
- F. CONTRACTOR shall arrange an anchor manufacturer's representative to provide on-site installation training for installation of their adhesive anchor system products. Submit documentation that all CONTRACTOR's personnel or subcontractors who install adhesive anchors have been trained prior to the announcement of anchor installation.
- G. Adhesive anchors in horizontal and upwardly inclined orientations to resist sustained tension loads are subject to the following requirements:
 - 1. They shall be installed by personnel certified by an applicable certification program. Certification shall include written and performance tests in accordance with the ACI/CRSI Adhesive Anchor Installer Certification program, or equivalent, as approved by ENGINEER.
 - 2. They require continuous special inspection during installation. CONTRACTOR shall notify ENGINEER and SPECIAL INSPECTOR of the schedule for these anchor installations to permit coordination of inspections.

3.04 SCREW ANCHORS

- A. Unless otherwise noted on the Drawings, screw anchor edge distance and spacing shall be in accordance with manufacturer's recommendations.
- B. Anchor embedment shall at least equal 6-bolt diameters.
- C. Installation procedures shall be in accordance with the manufacturer's printed installation instructions.
- D. Where location of anchors is adjustable, reinforcing steel shall be located prior to drilling holes and anchors shall be located to clear reinforcing steel.

END OF SECTION

SECTION 09 91 00

PAINTING

PART 1–GENERAL

1.01 SUMMARY

- A. Work Included: Surface preparation and application of paints and coatings.
- B. Related Sections and Divisions: Applicable provisions of Division 01 shall govern work in this section.

1.02 REFERENCES

- A. AMPP–Association for Materials Protection and Performance.
- B. ASTM B117–Standard Practice for Operating Salt Spray (Fog) Apparatus.
- C. ASTM D2247–Standard Practice for Testing Water Resistance of Coatings in 100% Relative Humidity.
- D. ASTM D3363–Standard Test Method for Film Hardness by Pencil Test.
- E. ASTM D4060–Standard Test Method for Abrasion Resistance of Organic Coatings by the Taber Abraser.
- F. ASTM D4541–Standard Test Method for Pull-Off Strength of Coatings Using Portable Adhesion Testers.
- G. ASTM D4585–Standard Practice for Testing Water Resistance of Coatings Using Controlled Condensation.
- H. Federal Register–Code of Federal Regulations (CFR).
- I. Federal Register–Resource Conservation and Recovery Act (RCRA).
- J. Federal Register–Comprehensive Environmental Response, Compensation, and Liability Act (CERCLA).
- K. ICRI–International Concrete Repair Institute.
- L. NACE–National Association of Corrosion Engineers.
- M. SSPC–The Society for Protective Coatings–Steel Structures Painting Manual.

1.03 SUBMITTALS

- A. Submittals shall be in accordance with provisions of Section 01 33 00–Submittals.

- B. Shop primer proposed for use shall be submitted with all material and equipment submittals. All shop primers shall be of the same generic type and quality as those specified herein.
- C. Submit manufacturer's Safety Data Sheets (SDS) for each type of paint with each shop drawing submittal. SDS sheets shall be posted at the construction site at all times painting is in progress.
- D. Substitution submittals shall include performance test data, as certified by a qualified testing laboratory, for the ASTM tests specified in Paragraph 2.01.

1.04 QUALITY ASSURANCE

- A. Regulatory Requirements: All paints, surface preparation, and application methods shall conform to federal requirements for allowable exposure to lead and other hazardous substances.
- B. Prepainting Meeting:
 - 1. A repainting meeting shall be held immediately following the project preconstruction conference. The repainting meeting is to be held prior to any material and equipment that requires painting is delivered to the site.
 - 2. CONTRACTOR, the paint subcontractor, and the paint manufacturer's representative shall be present to review the specifications and project scope.
 - 3. The paint manufacturer's representative shall review progress at the site as requested by ENGINEER. These are generally expected to be prior to monthly progress meetings.

1.05 FIELD QUALITY CONTROL

- A. Furnish testing apparatus as applicable for observing surface preparation, testing atmospheric conditions and testing coatings, prior to beginning surface preparation. Provide the following apparatus:
 - 1. One set of U.S. Department of Commerce thickness calibration plates, certified by the National Bureau of Standards, to test dry film thickness.
 - 2. One wet-film thickness gauge.
 - 3. One dry-film thickness gauge, Mikrotest III, 0 to 40 mils with calibration standard approved by the Bureau of Standards.
 - 4. One Bacharach Sling Psychrometer, Model 12-7011.
 - 5. Tinker and Razor Model M-1 Holiday Detector and recommended wetting agent.
 - 6. One set of SSPC-VIS 1-89 Visual Standards for Abrasive Blast Cleaned Steel.
- B. Provide access via scaffolding or staging for inspection.
- C. Entire surface of coated submerged concrete shall be tested with holiday detector. Mark and repair all pinholes, then retest until no pinholes are found.
- D. CONTRACTOR shall provide documentation to ENGINEER of conditions before and during painting operations for each area and each day's work. Documented conditions shall include the following at a minimum: date, area of work, system used, preparation methods, environmental conditions, quantity and thickness of coating placed, noted conditions, and nonconforming items. ENGINEER can provide sample report form if CONTRACTOR does not have their own.

1.06 DELIVERY, STORAGE, AND HANDLING

- A. Materials shall be delivered to the site in original containers with labels intact and seals unbroken.
- B. Drop cloths shall be used in all areas where painting is done to fully protect other surfaces.
- C. Oily rags and waste must be removed from the building each night or kept in an appropriate metal container.

1.07 ENVIRONMENTAL REQUIREMENTS

- A. CONTRACTOR shall dry-heat, dehumidify, and ventilate to obtain painting conditions recommended by the paint manufacturer during surface preparation, application, and cure.
- B. Relative humidity conditions as specified by the paint manufacturer's data sheet shall be adhered to. This includes times in which supplemental heat is used. Supplemental heat shall be indirect-fired hot air furnaces or electric heat. Open-flame heaters shall not be used.
- C. No unprotected, unheated exterior painting shall be undertaken when damp weather appears probable, nor when the temperature of the substrate is below 55°F, unless approval in writing is received from the paint manufacturer.

1.08 COLOR SELECTIONS

- A. Provide color charts for all coatings being used on the project. After initial selection of colors by OWNER, provide draw down samples of selected colors for OWNER's final approval. For stained wood, provide specified wood species sample with selected color for final approval.
- B. CONTRACTOR shall provide a summary sheet at the completion of the project listing the finish paint products used and the manufacturer's color identification for each item painted. This summary sheet should be submitted to ENGINEER and OWNER for review.

PART 2-PRODUCTS

2.01 ACCEPTABLE MANUFACTURERS

- A. All materials required for painting shall be types and quality as manufactured by Tnemec Company, Inc., Sherwin-Williams Company, Carboline, PPG Protective and Marine Coatings, or equal, unless noted otherwise in the schedule.
- B. Where thinning is necessary, only the products of the manufacturer furnishing the paint will be allowed. All such thinning shall be done strictly in accordance with the manufacturer's instructions.
- C. Paint and paint products of Tnemec Company and Sherwin-Williams, listed in the following specifications, are set up as standard of quality. Carboline and PPG Protective and Marine Coatings have preapproved equivalent products that shall be used. Other manufacturer's products will be considered as a substitution if CONTRACTOR and paint manufacturer certify that the products offered are recommended for the service intended, are compatible with the shop primers used, are equal in solids content and composition, and are of the same

type. Submittal shall include the following performance data as certified by a qualified testing laboratory. ASTM Specifications shall be the latest revision:

1. Abrasion—ASTM D4060, CS-17 Wheel, 1,000 grams load.
2. Adhesion—ASTM D4541.
3. Hardness—ASTM D3363.
4. Humidity—ASTM D2247 and D4585.
5. Salt (Fog) Spray—ASTM B117.

PART 3—EXECUTION

3.01 SURFACE PREPARATION

A. General:

1. All surfaces to be painted shall be prepared as specified herein and by the manufacturer's published data sheet and label directions. The objective shall be to obtain a uniform, clean, and dry surface.
2. No field painting shall be done before the prepared surfaces are observed by ENGINEER. Surfaces painted without such observation shall be abrasive-blast-cleaned and repainted.
3. Prior to field-blasting, a sample of the blast abrasive shall be provided to ENGINEER for pH testing. Additional samples of subsequent deliveries or batches of blast abrasive shall be provided to ENGINEER for pH testing.
4. For on-site abrasive-blasting, low-dust, low-silica content material shall be used. Coal slag abrasive shall be used on pipe and ferrous materials. Staurolite abrasive shall be used on concrete and concrete block.
5. Quality of surface preparations listed below are considered a minimum. If paint manufacturer requires a better preparation for a particular application, it shall be considered a requirement of this specification.
6. All concrete surfaces shall be tested for moisture in accordance with ASTM D4263 and, if necessary, F1869. Surfaces shall also be verified that the pH of the cleaned concrete surface to be coated is within the range of 8 to 11.

B. Ferrous Metal:

1. All ferrous metal to be primed in the shop shall have all rust, dust, and mill scale, as well as all other foreign substances, removed by abrasive blasting. Cleaned metal shall be primed or pretreated immediately after cleaning to prevent new rusting.
2. All ferrous metals not primed in the shop shall be abrasive-blasted in the field prior to application of the primer, pretreatment, or paint.
3. Abrasive blasting of metals in the shop shall be in accordance with SSPC-SP 10 Near White Blast Cleaning. Abrasive blasting of metals in the field for immersion service shall be in accordance with SSPC-SP 10 Near White Blast Cleaning. Abrasive blasting of metals in the field for nonimmersion service shall be in accordance with SSPC-SP6 Commercial Blast Cleaning.
4. Solvent cleaning in accordance with SSPC-SP1 shall precede all abrasive-blasting operations.
5. Ductile iron pipe shall be prepared by abrasive blasting per National Association of Pipe Fabricators NAPF 500-03-04 Abrasive Blast Cleaning.
6. Prior to finish coating, all primed areas that are damaged shall be cleaned and spot-primed.

- C. Concrete:
1. All concrete surfaces, including precast concrete to be painted, shall be cleaned of all form oil, curing compound, and other foreign matter. Concrete floors containing oil and grease residues shall be cleaned with detergent to remove all residues.
 2. All new concrete and precast concrete walls, floors, and ceilings shall be abrasive-blast cleaned in accordance with SSPC-SP13/NACE No. 6 in order to prepare the surfaces for adherence of the painting systems as specified. Abrasive blasting of concrete shall result in a surface profile in accordance with ICRI No. 03732 at CSP-3 to CSP-5.
 3. Bug holes, pits, voids, and cracks shall be filled as specified in Section 03 30 00—Cast-In-Place Concrete without placing a friable sand-cement surface overall. The dried surface shall be stoned down.
 4. Paint manufacturer shall observe and approve the surface preparation method and the prepared surface prior to painting.
 5. After cleaning, the surface shall be washed and all dust, sand, and loose particles shall be removed by vacuuming. If CONTRACTOR elects to blow the surfaces off with air, it shall be oil-free air, and the methods shall conform to OSHA requirements.
- D. Galvanized: Where galvanized items are not submerged or buried, they shall be cleaned with nonhydrocarbon solvent cleaner (such as Clean N Etch, or equal) in accordance with SSPC-SP1 and shall be abrasive-blasted in accordance with SSPC-SP16 Brush-Off Blast Cleaning.
- E. Wood:
1. Wood surfaces shall be thoroughly cleaned and free of all foreign matter. Cracks and nail holes and other defects shall be properly filled and smoothed.
 2. Wood trim shall be sandpapered to a fine finish and wiped clean of dust.

3.02 APPLICATION

- A. All materials shall be used as specified by the manufacturer's published data sheets and label directions.
- B. No paint shall be applied on a wet or damp surface and in no case until the preceding coat is dry and hard. Each coat shall be allowed to dry in accordance with manufacturer's data sheets before the next coat is applied.
- C. Drying time shall be construed to mean "under normal conditions." Where conditions are other than normal because of the weather or because painting must be done in confined spaces, other drying times will be necessary.
- D. Additional coats of paint shall not be applied, nor shall units be returned to service until paints are thoroughly dry and cured.
- E. Steel that will be inaccessible in the completed work shall receive the final coat before enclosure.
- F. Paint shall be applied to provide an opaque, smooth surface of uniform finish, color, appearance, and coverage. Cloudiness, spotting, holidays, laps, brush marks, runs, sags, or other surface imperfections will not be acceptable. Tops and bottoms of walls and areas that are "cut-in" by brush prior to rolling shall have a uniform appearance in comparison with adjoining surfaces.

- G. Crevices and other hard-to-apply areas shall be back-rolled/back-brushed in conjunction with application of the first field coat of primer or intermediate coat. This includes, but is not limited to, between pipe flanges, pipe flange/pipe barrel joints, equipment fittings, and other narrow openings.

3.03 FIELD QUALITY CONTROL

- A. Examination of work on the site by the manufacturer's representative shall be performed when requested by ENGINEER.

3.04 CLEANING

- A. All stains and marks shall be removed from other surfaces upon completion of the work.

3.05 SCHEDULE

A. General:

1. At the completion of the project, all painted surfaces which have been damaged shall be repainted or touched-up.
2. See Finish Schedule on the Drawings for an additional reference for areas to be painted.
3. The painter shall use some discretion in what should and should not be painted. Do not paint over labels and other information, bronze, machined surfaces, moving parts where painting may impair movement, hot surfaces which may peel, etc. If in doubt whether a part should be painted, ask ENGINEER.
4. Products listed first are Tnemec and second are Sherwin-Williams.

B. New Work:

1. All new work done by all trades shall be painted by CONTRACTOR in accordance with the following schedule and in accordance with paint manufacturer's recommendation. It is the intent of these specifications that all non-galvanized ferrous metal items scheduled for painting be shop-primed. If items are not shop-coated, surfaces shall be prepared and painted in the field as specified. If any items of new construction are not listed, CONTRACTOR shall request paint system from ENGINEER, and the items shall be painted as part of this Contract without additional cost.
2. Galvanized copper, brass, CPVC, and PVC; not submerged or buried:
 - a. Two coats of N69 Hi-Build Epoxoline, Macropoxy 646 Fast Cure for interior surfaces, or
 - b. One coat of N69 Hi-Build Epoxoline, Macropoxy 646 Fast Cure, and one coat of 1094 Endura-Shield, Acrolon 218HS for exterior surfaces.
 - c. For galvanized items that are embedded in construction, provide one coat before installing.
3. Insulation of equipment, pipes, and ductwork:
 - a. Two coats of Series 1029 Endurotone, DTM Acrylic.
 - b. Colored PVC jacketing shall not be painted.
4. Galvanized, copper, CPVC, and PVC; submerged or buried: Not painted.
5. Aluminum items:
 - a. Exposed areas of structural items such as railings and grating shall not be painted.
 - b. For structural items in contact with concrete, see Division 05.
6. Painted wood-outside:
 - a. Sherwin-Williams products.
 - b. One coat of A-100 Alkyd Exterior Wood Primer.
 - c. Two coats of A-100 Satin Latex House and Trim.

7. Stainless steel: Not painted.
8. Steel and Ductile Iron Insulated Coating Systems:
 - a. Tnemec Products:
 - (1) Primer coat shall be Tnemec Series 94-H20 Hydro Zinc.
 - (2) Two intermediate coats shall be Tnemec Series 971 Aerolon.
 - (3) Finish coat shall be Tnemec Series 1028T Enduratone HDP.
 - b. Sherwin Williams Products:
 - (1) Primer coat shall be Corothane I Galvapac 1K.
 - (2) Five Intermediate Coats shall be Heat-Flex® Hi-Temp 3500.
 - (3) Two finish coats shall be Shercryl HPA.
 - c. All finish colors selected by OWNER.
 - d. If equipment to be coated does not have a zinc-rich shop primer coating option, CONTRACTOR shall either surface prepare area as necessary or provide manufacturer recommended tie-coat.

C. Coverage:

1. Dry mil thickness shall conform to those specified. Mil test measurement shall conform to SSPC Steel Structures Painting Manual. Dry Film Thickness (DFT) shall be verified in accordance with SSPC-PA2.
2. The coatings listed will provide the mil thickness given when applied at the coverages listed. Upon the request of ENGINEER, such surfaces shall be checked by the painter with a calibrated mil thickness gauge and any deficiencies found in the film shall be remedied by additional coat(s) at the expense of CONTRACTOR.
3. On masonry, application rates will vary according to surface texture; however, in no case shall the manufacturer's stated coverage rate be exceeded. On porous surfaces, it shall be the painter's responsibility to achieve a protective and decorative pinhole-free finish either by decreasing the coverage rate or by applying additional coats of paint.
4. Coverages reflect manufacturer's recommendations using spray application techniques. Where brushing or rolling is specified or performed at the discretion of the painter, one additional coat, minimum, will be required to achieve total DFT as specified and recommended by the manufacturer.

	Min. Sq. Ft.** Coverage	Min. Dry Mil** Thickness Per Coat
Products		
1029 Endurotone, DTM Acrylic	200	
N69 Hi-Build Epoxoline II, Macropoxy 646 Fast Cure		
Steel or Impervious Substrate Primer Coat	---	4.0
Steel or Impervious Substrate Intermediate Coat(s)	---	5.0
Steel or Impervious Substrate Finish coat	---	5.0
135-1255 Chembuild, Macropoxy 646 Fast Cure	335	4.0
Steel Doors	---	3.0
20HS Pota-Pox, Macropoxy 646 Fast Cure		
Steel or Impervious Substrate Primer	---	4.0
Steel or Impervious Substrate Intermediate Coat(s)	---	5.0
Steel or Impervious Substrate Finish Coat	---	5.0
1094 Endura-Shield II, Acrolon 218HS	---	2.5
201 Epoxoprime, ArmorSeal 1000 HS Epoxy	250	
280 Tneme-Glaze, ArmorSeal 1000 HS Epoxy	250	
Epoxoblock WB 1254, Kem Cati-Coat HS	80	

	Min. Sq. Ft.** Coverage	Min. Dry Mil** Thickness Per Coat
N69 Hi-Build Epoxoline, Macropoxy 646 Fast Cure (Masonry and Concrete)	250	
Series 1 Omnithane, DuraPlate 235 (Primer)		3.0, 5.0
N69 Hi-Build Epoxoline II (Submerged)		6.0
Sher-Glass FF (Submerged)		12.0
Macropoxy 5500 LT (potable water system) Stripe Coat	---	5.0
Tnemec Series 94-H20, Sherwin Williams Corothane I Galvapak 1k Potable Water System Primer	---	3.0
Insulating Coating System Primer	---	3.0
Tnemec Series 21, Potable Water Stripe and Finish Coat	---	12.0
Sherwin Williams SherPlate 600 Potable Water Intermediate and Finish Coats	---	6.0
Tnemec Series 1224 Epoxoline Insulating Coating Tie-Coat	---	6.0
Tnemec Series 971 Aerolon Insulating Coating	---	50.0
Tnemec Series 1028 Enduratone Insulating Coating Topcoat	---	3.0
Sherwin Williams Heat-Flex® Hi-Temp 3500 Insulating Coating	---	20.0
Sherwin Williams Shercryl HPA Insulating Coating Topcoat	---	3.0
Sherwin-Williams Products		
ProMar 200 Primer (sprayed)	200	
ProMar200 Primer (rolled/brushed)	260	
ProMar 200 Enamel (sprayed)	280	
ProMar 200 Enamel (rolled/brushed)	360	
A 100 Alkyd Wood Primer (sprayed)	200	
A 100 Alkyd Wood Primer (rolled/ brushed)	260	
A 100 Satin Latex Trim (sprayed)	280	
A 100 Satin Latex Trim (rolled/ brushed)	360	
S-W Wood Classics Stain (sprayed)	390	
S-W Wood Classics Stain (rolled/brushed)	480	
S.W. Wood Classics Varnish (sprayed)	320	
S.W. Wood Classics Varnish (rolled/brushed)	360	

** Roller or brush application requires two or more coats to obtain recommended film thickness. No allowance is made here for overspray, waste in handling, mixing, or application. Final, minimum total DFT shall be equal to that specified. Paint submittals shall note where roller or brush application is proposed and the paint manufacturer's recommendations of number of coats to achieve the required thickness shall be noted.

Primer, intermediate and/or final surface colors shall be of contrasting colors to promote coverage.

END OF SECTION

Section 09 91 00-8

1667.011/2-2026

SECTION 20 05 53

IDENTIFICATION FOR FIRE SUPPRESSION, PLUMBING, AND HVAC PIPING AND EQUIPMENT

PART 1–GENERAL

1.01 SUMMARY

- A. Work Included: Perform all work required to furnish and install pipe and identification with supplementary items necessary for proper installation as specified herein, or shown on the Drawings. CONTRACTOR shall identify all equipment and piping.
- B. Related Sections and Divisions: Applicable provisions of Division 01 shall govern work in this section.

1.02 SUBMITTALS

- A. Submit shop drawings and product data in accordance with provisions of Section 01 33 00–Submittals.

1.03 REFERENCES

- A. The latest published edition of a reference shall be applicable to this Project unless identified by a specific edition date.
- B. All material, installation, and workmanship shall comply with the applicable requirements and standards addressed within the following reference: ASME A13.1–Scheme for the Identification of Piping Systems.

1.04 DELIVERY, STORAGE, AND HANDLING

- A. Store products in manufacturer’s unopened packaging with labels clearly identifying product name and manufacturer until ready for installation.
- B. Storage: Store materials in clean, dry area indoors until ready for installation.
- C. Handling: Protect materials and finish from damage during handling and installation.

PART 2–PRODUCTS

2.01 MANUFACTURERS

- A. Equipment tags and pipe markers shall be manufactured by Marking Services, Incorporated, Seton Name Plate Company, WH Brady Company, or Graphic Products, Inc.

2.02 PIPE MARKERS

- A. Manufacturers: Marking Systems, Inc., Seton Name Plate Company, W.H. Brady Company, or equal.

- B. Pipe markers shall conform to ANSI A13.1. Arrow markers must have same ANSI background colors as their companion pipe markers or be incorporated into the pipe identification marker.
- C. Plastic Pipe Markers: Factory-fabricated, flexible, semirigid plastic, preformed to fit around pipe or pipe covering; minimum information indicating flow direction arrow and identification of fluid being conveyed.
- D. Pipe markers and arrow markers also shall be provided for all piping systems.
- E. Use Seton Setmark type SNA or Brady Snap-on type identification for all piping systems, up through 6 inches. For piping systems larger than 6 inches, use Seton or Brady strap-on markers, or similar, by Marking Services, Inc. Self-adhesive labels that stick directly to the pipe or insulation jacketing are not acceptable. Provide lettering in accordance with the following table.

PIPE MARK SIZE CHART

Outside Pipe Diameter (Including Covering), Inch	Minimum Length of Label Field Color, Inch	Minimum Height of Letters, Inch
3/4 to 1 1/4	8	1/2
1 1/2 to 2	8	3/4
2 1/2 to 6	12	1 1/4
8 to 10	24	2 1/2
Over 10	32	3 1/2

PART 3–EXECUTION

3.01 INSTALLATION

- A. Installation shall meet or exceed all applicable federal, state, and local requirements and referenced standards and conform to code and ordinances of authorities having jurisdiction.

3.02 PIPE MARKERS

- A. Install pipe markers in accordance with manufacturer’s instructions.
- B. Install in clear view and align with axis of piping.
- C. All pipes shall be labeled with a minimum of two labels in each room, crawl space, or compartment. Locate identification at maximum 20-foot centers on straight runs, including risers and drops adjacent to each valve and tee, at each side of penetration of structure or enclosure, and at each obstruction. Labels shall be abbreviated as noted under fluid abbreviations on drawings.
- D. CONTRACTOR shall include a schedule in its submittal identifying the various pipe designations, abbreviations, and labeling scheme. Colors, text, and piping abbreviations are to be selected by OWNER, with the following piping marker scheme used where applicable.

Pipe Contents	Label Colors (Background/Text)
Natural gas	Brown/White

END OF SECTION

SECTION 23 05 23

GENERAL-DUTY VALVES FOR HVAC PIPING

PART 1–GENERAL

1.01 SUMMARY

- A. Work Included: Valve specifications for all Division 23 systems unless otherwise noted.
- B. Related Section and Divisions: Applicable provisions of Division 01 govern work under this section.

1.02 SUBMITTALS

- A. Submit product data under provisions of Section 01 33 00–Submittals.
- B. CONTRACTOR shall submit a schedule of all valves indicating type of service, dimensions, materials of construction, and pressure/temperature ratings for all valves to be used on the project. Temperature ratings specified are for continuous operation.

1.03 OPERATION AND MAINTENANCE DATA

- A. All operations and maintenance data shall comply with the submission and content requirements specified under Section 01 33 00–Submittals.

1.04 DESIGN CRITERIA

- A. Where valves are specified for individual mechanical services (i.e., hot water heating, steam, etc.) all valves shall be of the same manufacturer.

PART 2–PRODUCTS

2.01 GENERAL

- A. Manufacturers: Acceptable manufacturers are Apollo, Bell & Gossett, Crane, Danfoss-Flomatic, DeZurik, Fisher, Grinnell, Jamesbury, Milwaukee, Nibco, Vogt, Watts.

2.02 NATURAL GAS SYSTEM

- A. Exterior Aboveground Shutoff Valves: Black body, brass plug type with square head, top check and lock wing stop lock, threaded ends for 25 psi or less gas pressure requirements, McDonald No. 10687B, or equal.
- B. Pressure Regulators:
 - 1. Manufacturers: Rockwell, Maxitrol, Fischer, or equal.
 - 2. All pressure regulators shall be designed, manufactured and approved for natural gas service.

3. Pressure regulators for individual service lines shall be capable of reducing distribution line pressure to pressures required for users. Pressure relief shall be set at a lower pressure than would cause unsafe operation of any connected user. Regulator shall have a single port with orifice diameter no greater than that recommended by manufacturer for the maximum gas pressure at the regulator inlet. Regulator vent valve shall be of resilient materials designed to withstand flow conditions when pressed against valve port. Regulator shall be capable of limiting buildup of pressure under no-flow conditions to 50% or less of the discharge pressure maintained under flow conditions. Provide commercial-grade diaphragm type with internal relief valve, vent valve, cast iron body, and Buna-N diaphragm.
4. Pressure regulators indicated to be installed on gas piping exceeding 2 psig shall be provided with a tested and approved, integral overpressure protection device (OPD). Pressure regulators and OPD shall comply with ANSI Z21.80 (line regulators) or ANSI Z21.18 (appliance regulators).
5. Appliance regulators may be provided with a vent limiting device, where entire regulator and vent limiter complies with ANSI Z21.80 as an assembly and is installed in accordance with manufacturer's recommendations and NFPA 54.

PART 3-EXECUTION

3.01 GENERAL

- A. Properly align piping before installation of valves in an upright position; operators installed below the valves will not be accepted.
- B. Install valves in strict accordance with valve manufacturer's installation recommendations. Do not support weight of piping system on valve ends.
- C. Install all valves with the stem in the upright position. Valves may be installed with the stem in the horizontal position only where space limitations do not allow installation in an upright position or where large valves are provided with chain wheel operators. Where valves 2 1/2-inch and larger are located more than 12 feet 0 inches above mechanical room floors, install valve with stem in the horizontal position and provide a chain wheel operator. Valves installed with the stems down, will not be accepted.
- D. Install stem extensions when shipped loose from valve.
- E. Prior to flushing of piping systems, place all valves in the full-open position.
- F. Install all valves, and piping specialties, including items furnished by others, as specified and/or detailed. Make connections to all equipment installed by others where that equipment requires the piping services indicated in this section.
- G. Install valves for shutoff and to isolate equipment, parts of systems, or vertical risers. All valves shall be located such that servicing and operation is possible with adequate clearance for access. Install line shutoff valve at each branch connection to riser. Branch line shutoff valves shall be automatic type where shown on Drawings. Install valves with stems upright or horizontal, not inverted unless required otherwise by the valve manufacturer.

- H. Valves, regulators, flanges, unions, and similar appurtenances shall be accessible for operation and servicing.
- I. Shut-Off Valves: Install shut-off valves at all equipment, at each branch take-off from mains, and at each automatic valve for isolation or repair.
- J. Gas Pressure Regulators: When the gas pressure regulator is equipped with a vent connection, run a connection size vent to outside air in accordance with codes. Use a larger size vent when required by the manufacturer's installation instructions.

END OF SECTION

SECTION 23 11 23
FACILITY FUEL GAS PIPING

PART 1–GENERAL

1.01 SUMMARY

- A. Work Included: All facility fuel gas pipe and fittings unless otherwise noted.
- B. Related Sections and Divisions: Applicable provisions of Division 01 govern work under this section.

1.02 REFERENCES

- A. The latest published edition of a reference shall be applicable to this Project unless identified by a specific edition date.
- B. All material, installation, and workmanship shall comply with the applicable requirements and standards addressed within the following references.
 - 1. NFPA 54–National Fuel Gas Code (Current Edition).
 - 2. ANSI B16.3–Malleable Iron Threaded Fittings.
 - 3. ASTM A53–Pipe, Steel, Black and Hot-Dipped, Zinc Coated Welded and Seamless.
 - 4. ASTM A234–Pipe Fittings of Wrought Carbon Steel and Alloy Steel for Moderate and Elevated Temperatures.
 - 5. 2021 International Fuel Gas Code.

1.03 QUALITY ASSURANCE

- A. All materials, equipment and Work shall meet or exceed all applicable federal, state and local requirements and conform to codes and ordinances of authorities having jurisdiction.
- B. Welding Materials and Procedures: Conform to ASME Code and applicable state labor regulations.
- C. Order all Type E and Type S steel pipe with heat numbers rolled, stamped, or stenciled to each length or each bundle, depending on the size of the pipe, and in accordance with the appropriate ASTM specification.

1.04 SUBMITTALS

- A. Submittals shall be in accordance with provisions of Section 01 33 00–Submittals.

1.05 DELIVERY, STORAGE, AND HANDLING

- A. Accept piping on-site in shipping containers with labeling in place, inspect for damage and store with a minimum of handling. Store plastic piping under cover out of direct sunlight. Do not store materials directly on the ground.

- B. Provide temporary end caps and closures on piping and fittings. Maintain in place until installation.
- C. Protect piping systems from entry of foreign materials by installing temporary covers, completing sections of the work and isolating parts of completed system.
- D. Cover pipe to eliminate rust and corrosion while allowing sufficient ventilation to avoid condensation. Do not store materials directly on grade. Protect pipe, tube, and fitting ends so they are not damaged. Where end caps are provided or specified, take precautions so the caps remain in place.

1.06 DESIGN CRITERIA

- A. Use only new material, free of defects, rust and scale, and meeting the latest revision of ASTM specifications as listed in this specification.
- B. Construct all piping for the highest pressures and temperatures in the respective system in accordance with ANSI B31, but not less than 125 psig unless specifically indicated otherwise.
- C. Non-metallic piping will be acceptable only for the services indicated. It will not be acceptable in occupied spaces and ventilation plenum spaces, including plenum ceilings.
- D. Use only long radius elbows having a centerline radius of 1.5 pipe diameters.
- E. Where ASTM A53 grade A pipe is specified, ASTM A53 grade B pipe may be substituted at CONTRACTOR's option. Where the grade or type is not specified, CONTRACTOR may choose from those commercially available.

1.07 WELDER QUALIFICATIONS

- A. Before any metallic welding is performed, CONTRACTOR to submit their Standard Welding Procedure Specification together with the Procedure Qualification Record as required by Section IX of the ASME Boiler and Pressure Vessel Code and/or the National Certified Pipe Welding Bureau.
- B. Before any polyethylene fusion welding is performed, CONTRACTOR to submit certification that the welders to be used on this project have successfully demonstrated proper welding procedures in accordance with the Code of Federal Regulations, Title 49, Part 192, Section 192.285.
- C. ENGINEER and OWNER reserves the right to test the work of any welder employed on the project, at CONTRACTOR's expense. If the work of the welder is found to be unsatisfactory, the welder shall be prevented from doing further welding on the project.

PART 2–PRODUCTS

2.01 GENERAL

- A. All materials shall meet or exceed all applicable referenced standards, federal, state, and local requirements, and conform to codes and ordinances of authorities having jurisdiction.
- B. Natural gas pressures shall not exceed 2 psig on customer side of the meter.
- C. Buried natural gas shall be in accordance with Section 33 52 16–Fuel Gas Distribution Utilities.

2.02 NATURAL GAS

- A. 2-Inch and Smaller: ASTM A53, type E or S, standard weight (Schedule 40) black steel pipe with ASTM A197/ANSI B16.3 class 150 black malleable iron threaded fittings or ASTM A234 grade WPB/ANSI B16.9 standard weight, seamless, carbon steel weld fittings.
- B. 2 1/2-Inch and Larger: ASTM A53, type E or S, standard weight black steel pipe with ASTM A234 grade WPB/ANSI B16.9 standard weight, seamless, carbon steel weld fittings.
- C. Exposed piping shall be painted. All aboveground piping shall be labeled in accordance with Section 20 05 53–Identification for Fire Suppression, Plumbing, and HVAC Piping and Equipment. Where not labeled on manufacturer nameplate, regulator tags shall indicate inlet pressure, outlet pressure, and flow. Appliance regulators provided by equipment manufacturer as part of a manufacturer’s gas train are not required to be tagged.

2.03 VENTS AND RELIEF VALVE DISCHARGE PIPING

- A. Use pipe and pipe fittings as specified for the system to which the relief valve or vent is connected.

2.04 UNIONS AND FLANGES

- A. 2-Inch and Smaller: ASTM A197/ANSI B16.3 malleable iron unions with brass seats. Use black malleable iron on black steel piping and galvanized malleable iron on galvanized steel piping. Use unions of a pressure class equal to or higher than that specified for the fittings of the respective piping service but not less than 250 psi.
- B. 2 1/2-Inch and Larger: ASTM A181 or A105, grade 1 hot forged steel flanges of threaded, welding and of a pressure class compatible with that specified for valves, piping specialties and fittings of the respective piping service. Flanges smaller than 2 1/2-inch may be used as needed for connecting to equipment and piping specialties. Use raised face flanges ANSI B16.5 for mating with other raised face flanges on equipment with flat ring or full face gaskets. Use ANSI B16.1 flat face flanges with full face gaskets for mating with other flat face flanges on equipment.
- C. Provide ASTM A 193 B7 grade bolts and A 194 2H grade nuts and hardened washers for connections (star washers for grounding).

2.05 GASKETS

- A. Natural Gas Systems: Branded, compressed, non-asbestos sheet gaskets. Klingsil C4401, Garlock 3000, or JM Clipper 978-C.

PART 3-EXECUTION

3.01 PREPARATION

- A. Remove all foreign material from interior and exterior of pipe and fittings.

3.02 INSTALLATION

A. Support:

1. All interior or exposed pipelines shall be securely supported by adjustable metal saddles, brackets, or adjustable hangers supported directly by concrete, masonry work, or tile.
2. Strap hangers, tin clips, or U-hooks will not be acceptable.
3. In general, the maximum spacing of supports shall not exceed 10 feet on centers.
4. Insulation saddles shall be used. CONTRACTOR shall furnish and place hangers, supports, wall pipes, sleeves, and floor boxes in the forms before concrete is poured wherever needed or shown on the Drawings.
5. The weight of the piping shall be supported independently of connected equipment.
6. All supports and parts shall conform to the latest requirements of ASME B31 and shall have a structural safety factor of 5. Accurate weight balance calculation shall be made by CONTRACTOR to determine the required supporting force at each hanger location and the pipe weight load at each equipment connection. CONTRACTOR shall be responsible for the installation and application of the supports. Pipe hangers shall be capable of supporting the pipe weight load in all conditions of operation. The hangers shall allow free expansion and contraction of the piping to prevent excessive stress in the piping. Hangers and supports shall be spaced in accordance with ASME B31 and as indicated in this specification. Pipe supports shall be placed before and after a valve, expansion joint, or equipment so that stress will not be transferred to them.
7. CONTRACTOR shall provide calculations of pipe supports if requested by ENGINEER.
8. The following maximum spacings shall be provided for supports:

MAXIMUM HORIZONTAL PIPE HANGER AND SUPPORT SPACING

Nominal Pipe or Tube Size	Black Steel (See Note 1) ft
3/4	8
1	8
1 1/4	8
1 1/2	8
2	10
2 1/2	10
3	10
4	10

Nominal Pipe or Tube Size	Black Steel (See Note 1) ft
5	10
6	10
8	10
10	10
12	10

Note 1: Provide at least one hanger per pipe length located as close to the flange or joint on barrel as possible.

9. The length of hanger span and support spacing in the above table refers to straight lengths of pipe. When there are changes of direction in pipe, two supports shall be placed less than three-fourths the full span in the table. When practical, a hanger shall be located immediately adjacent to a change in direction of piping. Where there are concentrated loads between supports such as valves, spacing shall be based on load calculations rather than this table.
10. Provide saddles or shields under piping hanger and supports for all insulated piping to prevent crushing of insulation. Provide stainless steel pipe shields under stainless steel piping to prevent indentation of piping from the support or clamp.
11. Vertical piping shall be supported at each floor level and at intervals as specified for horizontal piping.

B. Layout:

1. Install all piping parallel to building walls and ceilings and at heights that do not obstruct any portion of a window, doorway, stairway, or passageway. Where interferences develop in the field, offset or reroute piping as required to clear such interferences. In all cases, consult Drawings for location of pipe spaces, ceiling heights, door and window openings, or other architectural details before installing piping.
2. Exposed piping shall run straight, in neat parallel lines, and shall be located far enough from walls, ceilings and floors, to permit access for covering of pipe and painting work.
3. Care shall be taken in laying out piping that there is no interference with the proper location of piping for other purposes or other equipment, and shall be run with regard to the requirements of each service.
4. Piping shall not interfere with headroom or clear floor space.
5. Plates shall be provided on all uncovered pipes passing through floors, walls, and ceilings, constructed of materials other than poured concrete. Plates shall be on exposed sides and shall be chrome-plated, spring and snap type.
6. An ample number of unions shall be provided in all threaded, soldered, and glued pipelines and at all equipment to facilitate removal and replacement. Install a shutoff valve at each appliance.
7. In joining two dissimilar types of pipe, standard fittings shall be used when available. The proposed joint shall be submitted by CONTRACTOR to ENGINEER for review prior to installation.

3.03 ERECTION

- A. Provide anchors, expansion joints, swing joints and/or expansion loops so that piping may expand and contract without damage to itself, equipment, or building.

- B. Mitered ells, notched tees, and orange peel reducers are not acceptable. On threaded piping, bushings are not acceptable.
- C. "Weldolets" and "Threadolets" may be used for branch takeoffs up to one-half the diameter of the main.
- D. Do not route piping through transformer vaults or above transformers, panelboards, or switchboards, including the required service space for this equipment, unless the piping is serving this equipment.

3.04 WELDED PIPE JOINTS

- A. Welding of pipe in normally occupied buildings is prohibited. Off-site welding is acceptable.
- B. If welding is required in a normally occupied building for connecting to an existing welded system, written approval from OWNER shall be obtained and shall comply with building's fire and life safety, as well as hot work requirements.
- C. Piping and fittings shall be welded and fabricated in accordance with ASME/ANSI latest editions of B31 for all systems from the Code for Pressure Piping. Machine beveling in CONTRACTOR's shop is preferred. Field beveling may be done by flame cutting to recognized standards.
- D. Provide complete penetration of deposited metal with base metal. Provide filler metal suitable for use with base metal. Maintain inside of fittings free from globules of weld metal.
- E. All welded pipe joints shall be made by the fusion welding process, employing a metallic arc or gas welding process. All pipes shall have the ends beveled 37 1/2 degrees and all joints shall be aligned true before welding. Except as specified otherwise, all changes in direction, intersection of lines, reduction in pipe size and the like shall be made with factory-fabricated welding fittings. Mitering of pipe to form elbows, notching of straight runs to form tees, or any similar construction shall not be permitted.
- F. Align piping and equipment so that no part is offset more than 1/16 inch. Set all fittings and joints square and true and preserve alignment during welding operation. Use of alignment rods inside pipe is prohibited.
- G. CONTRACTOR shall not permit any weld to project within the pipe so as to restrict it. Tack welds, if used, must be of the same procedure as the completed weld. Otherwise, remove tack weld during welding operation.
- H. Do not split, bend, flatten or otherwise damage piping before, during or after installation.
- I. Remove dirt, scale or other foreign matter from the inside of the piping, by swabbing or flushing, prior to the connection of other piping sections, fittings, valves or equipment.
- J. Schedule 40 pipe shall in no case be welded with less than three passes including one stringer/root, one filler and one lacer. Schedule 80 shall be welded with no less than four passes, including one stringer/root, two filler and one lacer. In all cases, the weld must be filled before the cap weld is added.

K. Weld Testing:

1. All welds are subject to inspection, visual and/or x-ray, for compliance with Specifications. OWNER will at OWNER's option, provide employees or employ a testing laboratory for the purposes of performing said inspections and/or x-ray testing. Initial visual and x-ray inspections will be provided by OWNER. CONTRACTOR shall be responsible for all labor, material and travel expenses involved in the reinspection and retesting of any welds found to be unacceptable. In addition, CONTRACTOR shall be responsible for the costs involved in any and all additional testing required or recommended by ASME/ANSI Standards B31.1 and B31.3 because of the discovery of poor, unacceptable or rejected welds.
2. Welds lacking penetration, containing excessive porosity or cracks, or are found to be unacceptable for any reason, must be removed and replaced with an original quality weld as specified herein. All qualifying tests, welding and stress relieving procedures shall, moreover, be in accordance with Standard Qualification for Welding Procedures, Welders and Welding Operators, Appendix A, Section 6 of the Code, current edition.

3.05 NATURAL GAS

- A. Pitch horizontal piping down 1-inch in 60 feet in the direction of flow. Install a 4-inch minimum depth dirt leg at the bottom of each vertical run and at each appliance. When installing mains and branches, cap gas tight each tee or pipe end which will not be immediately extended. All branch connections to the main shall be from the top or side of the main.
- B. Do not install gas pipe in a ventilation air plenum.
- C. If an above ground vent terminates in an area subject to snow accumulation, terminate the line at least five feet above grade.
- D. Piping through a roof shall be run through an approved roof penetration with flashing and counter flashing.
- E. Each gas pressure reducing valve vent and relief valve vent shall be run separately to a point outside of the building, terminated with a screened vent cap, and located according to gas utility regulations.
- F. Clean all welded piping before all regulators and control valves. Test by placing target cloth over piping and blow with compressed air. Clean piping until target cloth is clean and free of debris.

3.06 VENTS AND RELIEF VALVE DISCHARGE PIPING

- A. Install vent and relief valve discharge lines as indicated on the Drawings, as detailed, and as specified for each specific valve or piping specialty item. In no event is a termination to occur less than 6 feet above a roof line. Each gas pressure reducing valve vent and relief valve vent shall be run separately to a point outside of the building, terminated with a screened vent cap, and located according to gas utility regulations.
- B. Pipe vents from gas pressure reducing valves and pipe casing sleeves to the exterior of the building and terminate with outlet turned down and capped with corrosion resistant insect screen. Vent terminations shall be at least 7 feet abovegrade or pedestrian traffic and a

minimum of 3 feet above or 10 feet horizontally from all air intakes or building openings. Provide stainless steel insect screens on vent outlets.

3.07 UNIONS AND FLANGES

- A. Install a union or flange, as required, at each automatic control valve and at each piping specialty or piece of equipment which may require removal for maintenance, repair, or replacement. Where a valve is located at a piece of equipment, locate the flange or union connection on the equipment side of the valve. Concealed unions or flanges are not acceptable.
- B. Provide dielectric isolation device where nonferrous lines connect to ferrous lines or equipment, such as dielectric union, coupling, or dielectric flange fitting.

3.08 PIPING SYSTEM LEAK TESTS

- A. Piping system shall be tested as a complete unit or in sections. Under no circumstances shall a valve in a line be used as a bulkhead between gas in one section and test medium in an adjacent section, unless two valves in series are installed with a valved "telltale" located between these valves.
- B. Verify that the piping system being tested is fully connected to all components and that all equipment is properly installed, wired, and ready for operation. If required for the additional pressure load under test, provide temporary restraints at expansion joints or isolate them during the test. Verify that hangers can withstand any additional weight load that may be imposed by the test.
- C. All natural gas systems shall be inspected, tested, purged and placed into operation in accordance with NFPA 54 and as required by local code. Tester shall submit pneumatic tests to ENGINEER.
- D. Conduct pressure test with air. Test time and pressure shall be as indicated in the following table; additional time may be necessary to conduct an examination for leakage. Each test must be witnessed by ENGINEER. If leaks are found, repair the area with new materials and repeat the test; caulking will not be acceptable.

System	Pressure	Medium	Duration
Natural Gas	Test pressure shall be no less than 1.5 times the proposed maximum working pressure, but not less than 3 psi. Where the test pressure exceeds 125 psi, test pressure shall not exceed 50% minimum yield strength of pipe.	Air, carbon dioxide, nitrogen, or inert gas.	1/2 hour per 500 cubic feet pipe volume not to exceed 24 hours. Test duration shall be not less than 1/2 hour for each 500 cubic feet of pipe volume or fraction thereof. When testing a system having a volume less than 10 cubic feet the test duration shall be a minimum of 60 minutes. The duration of the test shall not be required to exceed 24 hours.

- E. Gradually increase the pressure to not more than one half of the test pressure; then increase pressure in steps of approximately one-tenth of the test pressure until the required test

pressure is reached. Examine all joints and connections with a soap bubble solution or equivalent method. After testing is complete, slowly release the pressure in a safe manner.

- F. All necessary piping, fittings, blind flanges, and apparatus for conducting tests shall be furnished by CONTRACTOR and shall comply with the requirements of NFPA 54 and as required by local codes.
- G. All new rough-in distribution piping and affected portions of existing systems connected to, shall be subjected to a pneumatic test pressure utilizing clean, dry air and must be demonstrated to be absolutely tight when subjected to the pressures and time durations listed in table above. All equipment and components designed for operating pressures of less than the test pressure shall not be connected to the piping system during test.
- H. Test pressure shall be measured with a manometer or with a pressure-measuring device designed and calibrated to read, record or indicate a pressure loss caused by leakage during the pressure test period.
- I. Piping system shall withstand test pressure specified without showing any evidence of leakage or other defects. Any reduction of test pressures as indicated by pressure gauges shall be deemed to indicate a leak unless can be attributed to some other cause.
- J. Leakage shall then be located by means of a gas detector, a noncorrosive leak detection fluid, or other leak detection method. Matches, candles, open flames or other methods that provide a source of ignition shall not be used.
- K. When placing system into operation, appliances and equipment shall not be placed into operation until piping system has been checked for leakage with above requirements.

3.09 PAINTING

- A. All carbon steel parts shall be furnished with all surfaces (except galvanized or stainless steel) prepared in accordance with near white grade SSPC Specification No. 10 removing all dirt, rust scale, and foreign materials. Surface preparation of all carbon steel parts shall be performed at such time during the assembly process as to preclude damage to the equipment once installed and assembled. Cleaned surfaces shall then be shop-primed. Shop-priming shall be with one coat of Tnemec N69-1255 Hi-Build Epoxoline primer, Tnemec 140-1255 Beige Pota-Pox, or equal, applied to a minimum of 5.0 mils dry thickness. Primer used shall be compatible with proposed finish coats; CONTRACTOR shall review. It is the intent of this specification that all equipment, supports, and appurtenances be furnished shop-primed, clean, and ready to accept finish painting by CONTRACTOR with a minimal amount of surface preparation.
- B. Exterior steel natural gas piping shall be painted as follows:
 - 1. One shop coat of N69-1255 Hi-Build Epoxoline, Macropoxy 646 Beige as primer.
 - 2. Touch-up primer prior to finish coat, and either:
 - a. Two coats of N69-Hi-Build Epoxoline II, Macropoxy 646 for interior surfaces; or
 - b. One coat of N69 Hi-Build Epoxoline II, Macropoxy 646; and one coat of 1074 Endura-Shield, Acrolon 218HS for exterior surfaces.

END OF SECTION

SECTION 26 05 00

GENERAL ELECTRICAL REQUIREMENTS

PART 1–GENERAL

1.01 SUMMARY

- A. Work includes general requirements for all electrical work.
- B. Related Sections and Divisions: Applicable provisions of Division 01 shall govern work in this section.

1.02 REFERENCES

- A. ANSI/NFPA 70–National Electrical Code (NEC).
- B. ANSI/IEEE C2–National Electrical Safety Code.

1.03 CONTRACT DOCUMENTS

- A. Any equipment roughed in improperly and/or not positioned on implied centerlines or as dictated by good practice shall be repositioned at no cost to OWNER.
- B. The Drawings are generally diagrammatic, and CONTRACTOR shall coordinate the work so that interferences are avoided. Provide all offsets in conduit, fittings, etc., necessary to properly install the work. All offsets, fittings, etc., shall be provided without additional expense to OWNER.

1.04 REGULATORY REQUIREMENTS

- A. Conform to ANSI/NFPA 70.
- B. Conform to ANSI/IEEE C2.
- C. The rules and regulations of the federal, state, local, and civil authorities and utility companies in force at the time of execution of the Contract shall become a part of this specification.
- D. Obtain electrical permits and inspections from authority having jurisdiction. Costs for permits and inspections shall be paid by CONTRACTOR.

1.05 CODES AND ORDINANCES

- A. CONTRACTOR is expected to know or to ascertain, in general and in detail, the requirements of all codes and ordinances applicable to the construction and operation of systems covered by this Contract. CONTRACTOR shall know or ascertain the rulings and interpretations of code requirements being made by all authorities having jurisdiction over the work to be performed by them.

- B. In preparing a Bid, CONTRACTOR shall include the cost of all items and procedures necessary to satisfy the requirements of all applicable codes, ordinances, and authorities, whether or not these are specifically covered by the Drawings and Specifications. All cases of apparent conflicts between the Drawings, Specifications, and codes shall be brought to ENGINEER's attention, as herein before specified. CONTRACTOR shall carry out work and complete construction as required by applicable codes and ordinances and in such a manner as to obtain approval of all authorities whose approval is required.
- C. When requested by ENGINEER, CONTRACTOR shall provide written calculations to show compliance with applicable codes or the Contract Documents. This shall include, but not be limited to, conduit and wire sizing, junction and pull box fill and sizing, conductor derating, and voltage drop. CONTRACTOR shall indicate calculation method used as well as compliance with applicable code, Drawing, or Specification.

1.06 EQUIPMENT PROVIDED UNDER OTHER DIVISIONS

- A. Included in this Contract are electrical connections to equipment provided under other divisions. CONTRACTOR shall refer to final shop drawings for equipment being furnished under other divisions, for exact location of electrical equipment, and the various connections required.

1.07 ELECTRICAL DISTRIBUTION SYSTEM

- A. Provide a complete electrical distribution system consisting of components indicated on the Drawings or specified herein including, but not limited to:
 - 1. 480-volt, three-phase, 4-wire service entrance conductors.
 - 2. Feeders, branch wiring, and electrical distribution equipment.
 - 3. All control wiring.
 - 4. Access panels and access doors for access to equipment installed by Division 26.
 - 5. Wiring between system components if equipment is not prewired.
 - 6. Support system design and supports for electrical raceways.
- B. Provide a standby power system consisting of components indicated on the Drawings (see Section 26 32 13.1–Standby Power System and Section 26 36 23–Automatic Transfer Switches).
- C. CONTRACTOR shall connect all equipment furnished by other Divisions consisting of components indicated on the Drawings or specified herein.
- D. Provide balancing and adjusting of electrical loads.
- E. CONTRACTOR shall instruct OWNER's representative in the operation and maintenance of all equipment. The instruction shall include a complete operating cycle on all apparatus.
- F. Provide miscellaneous items for a complete and functioning system as indicated on the Drawings and specified herein.
- G. A partial list of work not included in Division 26 is as follows: Painting (except as otherwise specified herein).

1.08 NOISE

- A. Eliminate any abnormal noises that are not considered by ENGINEER to be an inherent part of the systems as designed. Abnormal buzzing in equipment components will not be acceptable.

1.09 DRAWINGS

- A. The Drawings indicate approximate locations of the various items of the electrical systems. These items are shown approximately to scale and attempt to show how these items should be integrated with building construction. Locate all the various items by on-the-job measurements in conformance with Contract Documents and cooperation with other trades.
- B. Prior to locating equipment, confer with ENGINEER as to desired location in the various areas. In no case should equipment locations be determined by scaling drawings. Relocate equipment and bear cost of redoing work or other trades' work necessitated by failure to comply with this requirement.
- C. In certain instances, electrical devices and equipment, may be relocated. Where relocation is within 10 feet of the location shown on the Drawings, and when CONTRACTOR is informed of necessary relocation before work has begun on this portion of the job, the relocation shall be at CONTRACTOR's expense.
- D. The Drawings are schematic in nature and are not intended to show exact locations of conduit but rather to indicate distribution, circuitry, and control.

1.10 EXISTING UNDERGROUND UTILITIES

- A. The Booster Station 4 Drawings show approximate location of existing underground utilities based on OWNER-provided record drawings. CONTRACTOR shall excavate and verify the location of all underground utilities prior to installing new electrical equipment and prior to making modifications to existing electrical. This shall include, but not be limited to, feeders to structures and equipment, branch circuit wiring, phone and communication cabling, instrument wiring, and control wiring. CONTRACTOR shall temporarily relocate existing underground utilities to keep the existing facility in operation and for any new construction, and all costs for relocating existing electrical shall be included in the Bid.
- B. Record Drawings of Booster Stations 2 and 3's existing underground utilities are not available. CONTRACTOR shall excavate and verify the location of all underground utilities prior to installing new electrical equipment and prior to making modifications to existing electrical. This shall include, but not be limited to, feeders to structures and equipment, branch circuit wiring, phone and communication cabling, instrument wiring, and control wiring. CONTRACTOR shall temporarily relocate existing underground utilities to keep the existing facility in operation and for any new construction, and all costs for relocating existing electrical shall be included in the Bid.

1.11 SUBMITTALS

- A. CONTRACTOR shall submit to ENGINEER for approval prior to beginning work, shop drawings on the equipment and materials proposed to be furnished and installed. See Section 01 33 00–Submittals for requirements.

- B. CONTRACTOR shall, in addition, submit drawings and/or diagrams for review and for job coordination in all cases where deviation from the Contract Drawings are contemplated because of job conditions, interference or substitution of equipment, or when requested by ENGINEER for purposes of clarification of CONTRACTOR's intent. CONTRACTOR shall also submit detailed drawings, rough-in sheets, etc., for all special or custom-built items or equipment. Drawings and details under this section shall include, but not be limited to, electrical interconnection wiring diagrams, where applicable to this project.
- C. These drawings and diagrams shall show applicable electrical switch and breaker sizes as well as the manufacturer's name and catalog number for each piece of equipment used.
- D. Equipment and material submittals must show sufficient data to indicate complete compliance with Contract Documents as follows:
 - 1. Proper sizes and capacities.
 - 2. That the item will fit in the available space in the manner that will allow proper service.
 - 3. Construction materials and finishes.
- E. When the manufacturer's reference numbers are different from those specified, provide correct cross-reference number for each item. The shop drawings shall be clearly marked and noted accordingly.
- F. When fixtures, equipment, and items specified include accessories, parts, and additional items under one designation, shop drawings shall be complete and include all components.
- G. See additional requirements of shop drawings under Division 01—General Requirements.

PART 2—PRODUCTS

2.01 STANDARD PRODUCTS

- A. All equipment and products shall be of new manufacture per applicable specifications.
- B. All equipment shall be UL and NEMA approved.
- C. Unless specified otherwise, major distribution equipment shall each be by the same manufacturer.
- D. All equipment and wiring shall be selected and installed for conditions in which it will perform (e.g., general purpose, weatherproof, raintight, dust-tight, or any other special type).

2.02 SUBSTITUTION OF MATERIALS AND EQUIPMENT

- A. While it is not the intention of OWNER to discriminate against any manufacturer of equipment which may be equivalent to specified equipment, a strict interpretation of such equivalency will be exercised in considering any equipment offered as a substitute for specified equipment. CONTRACTOR shall submit with each request for approval of substitute material or equipment sufficient data to show conclusively that it is equivalent to that specified in the following respects:

1. Performance:
 - a. Capacity at conditions scheduled shall be equal to or greater than that of the specified equipment.
 - b. Energy consumption at the point of rating shall not exceed that of the specified equipment.
 - c. Vibration and noise production at the point of rating shall not exceed that of the specified equipment.
 2. Materials of construction.
 3. Gauges, weights, and sizes of all portions and component parts.
 4. Design arrangements, methods of construction, and workmanship.
 5. Coatings, finishes, and durability of wearing parts.
 6. National reputation of the manufacturer as a producer of first quality equipment of the type under consideration.
 7. Availability of prompt, reliable, and efficient service facilities franchised by or affiliated with the equipment manufacturer. This shall include the maintenance of local stocks of critical replacement parts equal to those maintained for the specified equipment.
- B. Requests for substitution shall include CONTRACTOR's reason for the request.
- C. If ENGINEER does not consider the items equivalent to those specified, CONTRACTOR shall provide those specified.

2.03 LOW-VOLTAGE WIRING (LESS THAN 100 VOLTS)

- A. Low-voltage wiring specified in this section shall be applicable to all systems installed that utilize low-voltage wiring where such wiring is not specified in other technical sections.
- B. All wiring shall have copper conductors with 300-volt insulation rating and meet the requirements of NEC Article 725.
- C. All conductors must be suitable for the application intended. Conductors 16 AWG and larger shall be stranded. Conductors 18 AWG and smaller may be solid or stranded.
- D. Control Cable for Class 1 Remote Control and Signal Circuits: Individual conductors twisted together, shielded, and covered with an overall PVC jacket. Cable shall be UL listed, temperature rated, and plenum or nonplenum rated for the application as required in the National Electrical Code.
- E. Control Cable for Class 2 or Class 3 Remote Control and Signal Circuits shall be constructed, UL listed, temperature rated, and plenum or nonplenum rated for the application as required in the NEC Article 725.

PART 3—EXECUTION

3.01 CONTINUITY OF SERVICE

- A. CONTRACTOR shall provide and maintain continuous services (power, controls, alarms, etc.) during the entire construction period.

- B. No service shall be interrupted or changed without permission from OWNER. Written permission shall be obtained before any work is started.
- C. When interruption of service is required, all persons concerned shall be notified and a prearranged time agreed upon. Notice shall be a minimum of 72 hours prior to the interruption.

3.02 CLEANUP AND REMOVAL OF RUBBISH

- A. All disconnect switch enclosures, junction boxes, and pullboxes shall be cleaned of debris and wires neatly arranged with surplus length cut off before installation of covers.
- B. Equipment shall be thoroughly cleaned of all stains, paint spots, dirt, and dust. All temporary labels not used for instruction or operation shall be removed.

3.03 CONCRETE WORK

- A. All cast-in-place concrete for new electrical equipment bases shown on the Drawings shall be provided by CONTRACTOR, except where specifically noted to be provided by others. All new equipment shall be set on 3 1/2-inch minimum leveling slabs including MCCs, freestanding enclosures, switchgear, etc. Pads shall be 3 inches larger than equipment being supported.
- B. Concrete shall comply with Section 03 30 00—Cast-In-Place Concrete.
- C. Provide all anchor bolts, metal shapes, and templates to be cast in concrete or used to form concrete for support of electrical equipment.

3.04 PAINTING

- A. All painting of electrical equipment shall be done by CONTRACTOR unless equipment is specified to be furnished with factory-applied finish coats.
- B. All electrical equipment shall be provided with factory-applied prime finish, unless otherwise specified.
- C. If the factory finish on any equipment furnished by CONTRACTOR is damaged in shipment or during construction, the equipment shall be refinished by CONTRACTOR.
- D. One can of touch-up paint shall be provided for each different color factory finish which is to be the final finished surface of the product.

3.05 CAULKING

- A. Caulk with a caulking sealant where indicated on the electrical drawings or hereinafter specified.
- B. Caulking sealant shall be silicone construction sealant as manufactured by General Electric or two-part polysulfide conforming to the requirements and bearing the seal of Thiokol Chemical Corporation.

- C. Caulking sealant shall contain no acid or ingredients that will stain stone, corrode metal, or have injurious effect on painting. It shall be colored to match adjacent surroundings.

3.06 BUILDING ACCESS

- A. CONTRACTOR shall arrange for the necessary openings in the building to allow for admittance of all apparatus.
- B. When the installation requires openings and access through existing construction and the openings are not provided, CONTRACTOR shall provide the necessary openings.

3.07 COORDINATION

- A. Provide wiring for all motors and all electrically powered or electrically controlled equipment.
- B. All disconnects, relays, wire, conduit, push buttons, pilot lights, and other devices for the power and control of electrical equipment shall be provided by CONTRACTOR except as specifically noted elsewhere in these specifications or on the Drawings.
- C. Where devices are provided by others, they shall be connected and wired by CONTRACTOR.
- D. CONTRACTOR shall provide all line voltage power and control wiring (100 volts and above), including temperature control wiring for operation, control, and supervision of all motorized equipment. Low-voltage control wiring (below 100 volts) shall be provided by CONTRACTOR supplying the equipment that has low-voltage wiring, unless otherwise noted. CONTRACTOR shall provide raceways for all low-voltage wiring.
- E. CONTRACTOR shall connect and wire all apparatus according to approved wiring diagrams furnished by the various trades.

3.08 EXCAVATION AND BACKFILL

- A. Backfilling of all trenches beneath concrete floor and stair slabs within building shall be accomplished with gravel fill and shall be specially compacted to same density as surrounding area. Backfill of exterior trenches shall be compacted granular fill, unless otherwise noted. Compaction shall meet the requirements of Section 31 23 00—Excavation, Fill, Backfill, and Grading. Refer to Section 26 05 33—Conduit for additional requirements associated with PVC conduit installed in earth.
- B. Lines passing under foundation walls shall have a minimum of 1 1/2-inch clearance.
- C. Care shall be taken so that there is no disturbance of bearing soil under foundations.
- D. CONTRACTOR shall follow underground pipe runs where possible to avoid additional rock excavation. See Division 31 for rock excavation requirements.

3.09 EQUIPMENT ACCESS AND LOCATION

- A. CONTRACTOR shall coordinate work of this division with that of other divisions so that all systems, equipment, and other components of the building will be installed at the proper time, will fit the available space, and will allow proper service access to those items requiring maintenance. This means adequate access to all equipment, not just that installed under this division. Any components for the electrical systems that are installed without regard to the above shall be removed and relocated as required to provide adequate access at CONTRACTOR's expense.
- B. Where various items of equipment and materials are specified and scheduled, the purpose is to define the general type and quality level, not to set forth the exact trim to fit the various types of ceiling, wall, or floor finishes. Provide materials that will fit properly the types of finishes actually installed.
- C. All equipment, junction and pull boxes, and accessories shall be installed to permit access to equipment for maintenance. Any relocation of conduits, equipment, or accessories to provide maintenance access shall be accomplished by CONTRACTOR at no additional cost.
- D. Electrical equipment, devices, instruments, hardware, etc., shall be installed with ample space allowed for removal, repair, calibration, or changes to the equipment. Ready accessibility to equipment and wiring shall be provided without moving other equipment that is to be installed or that is already in place.
- E. Locate electrical equipment to fit the details, panels, decorating, or finish of the space. ENGINEER shall reserve the right to make minor position changes before the work has been installed.

3.10 WORKMANSHIP

- A. All work shall be performed in compliance with the NEC.
- B. Install work using procedures defined in NECA Standard of Installation.
- C. Locations of utilization equipment and control devices as shown on the Drawings are within 10 feet of actual positions. Any mounting of this equipment within this 10-foot distance shall be performed at no additional cost.
- D. Unless otherwise noted, conduit shall be fastened to building structure or equipment framework and not placed on the floor.
- E. Where materials, equipment apparatus, or other products are specified by manufacturer, brand name, and type or catalog number, such designation is to establish standards of desired quality and style and shall be the basis of the Bid.
- F. Materials and equipment of the types for which there are National Board of Fire Underwriters Laboratories (UL) listing and label service shall be so labeled and shall be used by CONTRACTOR.

3.11 AREA CLASSIFICATIONS

- A. Where referenced herein, damp and wet locations shall include, but not be limited to, all NEMA 4X areas, structures and areas below grade, and exterior locations.

3.12 MODIFICATIONS TO EXISTING CONSTRUCTION

- A. Alterations:
 - 1. Alter, extend, and reconnect conduits as necessary.
 - 2. Reconnect existing conduits that were reused, cut, or exposed because of construction as quickly as possible.
 - 3. Where wiring is involved, new wires shall be "pulled in" between the nearest available accessible reused outlets to the extent allowed by the governing code.
 - 4. Provide new conduits for wires if they cannot be "pulled in" to existing conduits.
 - 5. All new conduits, wiring, and electrical items shall be connected to the existing systems so as to function as a complete unit.
 - 6. Where existing electrical equipment, devices, fixtures, electrically operated items, etc., interfere with any remodeling work, they shall be removed and reinstalled in another location to avoid such interferences. All existing and relocated equipment shall be left in good operating condition.
- B. CONTRACTOR shall remove all electrical equipment, conduit, and wiring associated with the structures, equipment, and control systems specified herein and/or shown on the Drawings to be removed.
- C. Include in Bid removal of existing electrical material and equipment as specified hereinafter, as noted on the Drawings, or as needed by field conditions.
- D. Provide stainless steel cover plates for all existing recessed outlet and junction boxes not being reused. Seal or cap all existing conduit penetrations not being reused.

END OF SECTION

SECTION 26 05 19

WIRE

PART 1–GENERAL

1.01 SUMMARY

- A. Work Included:
 - 1. Wire.
 - 2. Wiring Connections and Terminations.
 - 3. Terminal Blocks and Accessories.
- B. Related Sections and Divisions: Applicable provisions of Division 01 shall govern work in this section.

1.02 QUALITY ASSURANCE

- A. Manufacturers of Wire: Firms regularly engaged in the manufacture of electrical wire products of the types and ratings needed whose products have been in satisfactory use in similar service for not less than 5 years.
- B. Installer: A firm with at least 5 years of successful installation experience on projects with electrical wiring installation work similar to that in this project.
- C. Code Compliance: Comply with National Electrical Code (NFPA 70) and any and all local codes as applicable to construction and installation of electrical wiring devices, material, and equipment herein specified.
- D. UL Labels: Provide electrical material, which has been listed and labeled by Underwriters Laboratories.
- E. NECA Standard: Comply with applicable portions of National Electrical Contractor's Association's "Standard of Installation."

1.03 SUBMITTALS

- A. Submit shop drawings and product data under the provisions of Section 01 33 00–Submittals.
- B. Submit shop drawings for wiring system including layout of distribution devices, branch circuit conduit and cables, circuiting arrangement, and outlet devices.
- C. Submit manufacturer's instructions.

1.04 PRODUCT DELIVERY, STORAGE, AND HANDLING

- A. Provide factory-wrapped, waterproof, flexible-barrier material for covering wire on wood reels, where applicable, and weather-resistant fiberboard containers for factory-packaging

of wire, connectors, outlets, boxes, fuses, etc., to protect against physical damage in transit. Do not install damaged wire or other material; remove from project site.

- B. Store wire and other material in factory-installed coverings in a clean, dry, indoor space which provides protection against the weather.

PART 2–PRODUCTS

2.01 WIRE

- A. All wire for permanent installation shall be new stranded copper delivered to project in unopened cartons or reels, except where specifically noted and be UL listed for the use intended. No wire smaller than 12 AWG shall be used unless specifically noted. The use of multiconductor cable is not allowed.
- B. Motor circuit branch wiring and associated control wiring:
 - 1. Insulation type shall be THHN (indoors, nonVFD application).
 - 2. Minimum size for motor control wiring shall be 14 AWG.
 - 3. Control wiring for supervisory equipment shall be shielded, sized per equipment manufacturer's recommendations.
- C. All wiring within control panels and supervisory control centers that does not extend outside of the enclosure shall be insulation-type MTW, minimum size 16 AWG.
- D. Wiring in dry locations shall be THHN. Wiring in damp and wet locations shall be XHHW-2.
- E. Refer to Section 26 05 53–Electrical Identification for required wire insulation color coding and conductor labeling requirements. Initial phase color shall be used throughout the run, even for switch legs. Colors must meet code requirements for each class voltage. Do not duplicate colors, including neutral, on different voltages.
- F. Branch circuit wiring for exit lights, emergency lights, and exterior lights in excess of 75 feet shall be minimum 10 AWG. Circuits 150 feet or over shall be sized for a maximum 2% voltage drop.

2.02 WIRING CONNECTIONS AND TERMINATIONS

- A. Provide crimp type UL or ETL listed terminations for 6 AWG and smaller stranded conductor connections to electrical devices and equipment such as receptacles, switches, and terminal strips. Crimp devices shall be Sta-kon, or equal.
- B. Provide insulated, silicone-filled spring wire connectors with plastic caps for 8 AWG conductors and smaller. Connectors shall be King Silicone-Filled Safety Connectors, or equal. Spring wire connectors shall only be allowed in junction, outlet, or switch boxes. Spring wire connectors are not allowed for terminating motor conductors.
- C. No splices will be allowed unless reviewed by ENGINEER. Where allowed, provide in-line splices for all conductor connections, 6 AWG and larger. Splice compression connectors for installation above grade shall be UL listed in-line copper barrel-type as manufactured by Burndy Type YS-TC, or equal, with heat shrink tubing to match the conductor size. Splice

compression connectors for installation below grade shall be UL listed in-line copper barrel-type as manufactured by Burndy Type YS, or equal, with heat shrink tubing to match the conductor size. Splice compression shall be made with a manufacturer-recommended crimp tool.

- D. Above-ground reducing adapters shall be UL listed in-line copper barrel reducers as manufactured by Burndy Type YSR-TC, or equal, with heat shrink tubing to match the conductor size.
- E. Heat shrink tubing for splices and reducing adapters shall be UL listed, heavy wall type as manufactured by Burndy Type HS-H-PF, or equal, to match the conductor size.

2.03 TERMINAL BLOCKS AND ACCESSORIES

- A. Terminal Blocks: ANSI/NEMA ICS 4: UL listed or UL recognized under UL 467, UL 486E, UL1059, and UL 1953 (power terminals only).
- B. Signal and Control Terminal Blocks:
 - 1. General-Purpose Terminal Blocks:
 - a. Terminal blocks shall be rated up to 600 volts AC/DC.
 - b. Terminal blocks shall accept center-mounted jumper bars without increasing the installed space.
 - c. Terminal blocks shall be Allen-Bradley Bulletin 1492-J, or equal.
 - d. Terminal block color shall be gray.
 - 2. Grounding Terminal Blocks:
 - a. Terminal blocks shall be Allen-Bradley Bulletin 1492-JG, or equal.
 - b. Terminal block color shall be green/yellow.
 - 3. Disconnect-type Terminal Blocks (300-Volt Class):
 - a. Terminal blocks shall be feed-through type with a knife-blade disconnect.
 - b. Terminal blocks shall be Allen-Bradley Bulletin 1492-JKD, or equal, depending on the application.
 - c. Terminal block color shall be gray.
 - 4. Fuse-type Terminal Blocks with Indicator (300-Volt Class):
 - a. Terminal blocks for applications from 100 to 300 volts AC shall be Allen-Bradley Bulletin 1492-H4, or equal, with neon blown-fuse indicator.
 - b. Terminal blocks for applications from 10 to 50 volts AC/DC shall be Allen-Bradley Bulletin 1492-H5, or equal, with LED blown-fuse indicator.
 - c. Terminal block color shall be black.
 - 5. Terminal blocks shall have self-locking screw compression clamps rated for the size of conductors being terminated and upstream overcurrent protection for each application.
 - 6. The same manufacturer and style of terminal block shall be used throughout the entire project for all applications.
 - 7. Terminal blocks shall have tin-plated copper current bars and tin-plated steel screws. Terminal housings shall be completely finger safe from all live circuits and be constructed of self-extinguishing material with minimum UL 94-V0 flammability rating.
 - 8. Terminal blocks shall accept pre-printed, snap-in labeling cards on both sides without increasing the installed space. Provide terminal block manufacturer's end barriers and screw-type retainers for all terminal block groupings.
 - 9. Terminal blocks shall mount on standard DIN rail and shall be able to be removed without removing adjacent terminal blocks.

10. Multi-level terminal blocks and stacked, single-level terminal block installations are not acceptable.

C. Refer to Section 26 05 53—Electrical Identification for terminal block labeling requirements.

PART 3—EXECUTION

3.01 GENERAL WIRING METHODS

- A. Install electrical wire and connectors in accordance with the manufacturer's written instructions, applicable requirements of the NEC, the National Electrical Contractors Association's "Standard of Installation," and in accordance with recognized industry practices so that products serve the intended functions. Use appropriate wiring methods and materials for the equipment or environment.
- B. Stranded conductors shall be terminated using crimp-type devices specified herein. Conductors may not be wrapped around a terminal screw.
- C. Place an equal number of conductors for each phase of a circuit in the same raceway.
- D. Torque conductor connections and terminations with calibrated torque wrench to manufacturer's recommended values. Provide permanent marking on lug, bolt, nut, or connection for conductors larger than 4 AWG.
- E. Splice only in junction or outlet boxes. Splicing is not allowed in disconnects, panelboards, control panels, equipment, etc. Avoid splices between terminals of interconnecting power and control wiring.
- F. Spring wire connectors shall only be used in junction boxes. Equipment wireways (e.g., panelboards, disconnects, etc.), and control panels shall not have any spring-wire connectors installed; all terminations shall be on terminal strips.
- G. Neatly train, lace, and tie wrap all wiring inside boxes, equipment, control panels, MCCs, and panelboards.
- H. Make conductor lengths for parallel circuits equal.
- I. The same color shall be used for each numbered wire throughout its entire length.
- J. Terminate all wiring on terminal blocks in control panels, VFD enclosures, starter cubicles, and similar equipment. This shall include all spare or unused wires.
- K. Provide a dedicated neutral for each branch circuit or feeder requiring a neutral. Ampacity of neutral conductor shall match that of the branch circuit or feeder.
- L. Do not use a pulling means that can damage the raceway.
- M. Signal wiring (below 100 volts) must be in a conduit separate from power and/or control wiring (over 100 volts). Signal wire shall include, but not be limited to, loop-powered devices,

voice and data communications, and communication wiring (i.e., Ethernet, serial, etc.). Analog wiring shall be in a conduit separate from all other wiring.

- N. Provide junction or pull boxes to facilitate the “pulling in” of wires or to make necessary connections. All raceways and apparatus shall be thoroughly blown out and cleaned of foreign matter prior to pulling in wires.
- O. Thoroughly clean wires before installing lugs and connectors.
- P. Make splices, taps, and terminations to carry full capacity of conductors without perceptible temperature rise.
- Q. Terminate spare conductors within equipment, control panels, etc., on terminal strips and label as “SPARE.” Spare wiring in pull or junction boxes may be terminated with electrical tape and labeled as “SPARE.” All spare conductor labels shall indicate where the conductors terminate. Refer to Section 26 05 53–Electrical Identification, for additional requirements.

3.02 GENERAL LOW-VOLTAGE WIRING METHODS (LESS THAN 100 VOLTS)

- A. Low-voltage wiring installation requirements specified herein shall be applicable to all systems installed that utilize low-voltage wiring where such wiring installation is not specified in other technical sections.
- B. Low-voltage wiring shall be installed in conduit.
- C. Control wiring for HVAC and lighting equipment connected to standby power shall be installed in conduit.
- D. Do not use wire smaller than 14 AWG for control wiring greater than 60 volts, or 18 AWG for voltages less than 60 volts. All sizes subject to NEC 725 requirements.
- E. Low-voltage cable splices shall only be allowed in junction boxes.

3.03 WIRING INSTALLATION IN RACEWAYS

- A. Pull all conductors into a raceway at the same time. Use UL-listed wire-pulling lubricant for pulling 4 AWG and larger wires. Wax-based pulling lubricant is not allowed unless it includes a Teflon additive.
- B. Install wire in raceway after interior of building is enclosed, watertight, and dry, and all mechanical work likely to injure conductors has been completed.
- C. Completely and thoroughly swab raceway system before installing conductors.
- D. Conductors No. 6 AWG and larger shall be pulled into conduits by hand or by utilizing a tugger with built-in tension meter. Other motorized machines of any type are not allowed for any wire pulling. CONTRACTOR shall provide a report to ENGINEER for each pull indicating maximum tension reached during the pull along with manufacturer’s maximum pulling tension.

- E. Conductors shall be installed in conduit system in such a manner that insulation is not damaged, conductors are not overstressed in pulling, and walls are not damaged. No splices are permitted except in junction boxes or outlet boxes.
- F. CONTRACTOR shall observe code limitation on the number and size of wires in an outlet box. CONTRACTOR shall either lay out work so that the wires do not exceed the particular box limitation or provide larger boxes approved for additional capacity.
- G. Panel riser feeder conductors shall be identified with colored tape at panel lugs. The same phase relation shall be maintained throughout.
- H. Circuiting is indicated diagrammatically on the Drawings.

3.04 TERMINAL BLOCK INSTALLATION

- A. A maximum of one conductor shall be installed on the field-wired side of each terminal block. If rated to accept more than one conductor, a maximum of two conductors shall be installed on the enclosure-wired side of each terminal block. Provide additional terminal blocks and shorting jumpers as required.
- B. Provide a separate ground-type terminal block for each shielded-cable drain conductor.
- C. Provide ten percent spare terminal blocks for each type of connected terminal block, minimum five spare terminal blocks total. For each grouping of terminal blocks, provide 25% spare DIN rail space.
- D. Maintain a minimum of 1 1/2 inches between terminal blocks and adjacent devices and enclosure wireways.

3.05 FIELD QUALITY CONTROL

- A. Inspect wire for physical damage and proper connection.
- B. Prior to energizing, check conduit, raceways, outlet boxes, and wire for continuity of circuitry and for short circuits. Correct malfunction when detected.
- C. Subsequent to wire hookups, energize circuitry and demonstrate functionality in accordance with these specifications.
- D. Perform continuity test on all power and equipment branch circuit conductors. Verify proper phasing connections.
- E. Perform field inspection and testing according to provisions of this section.

3.06 ACCEPTANCE TESTS

- A. CONTRACTOR shall furnish all materials, labor, and equipment necessary for the acceptance tests specified herein. Acceptance tests shall be performed in the presence of OWNER or OWNER's representative and must be passed before final acceptance of the work.

- B. CONTRACTOR shall be responsible for powered tests of each field-installed device unless specifically noted otherwise. CONTRACTOR shall be responsible for device operation as powered from its power source and signals as received at the I/O modules.
- C. Operation Test: By operational testing, OWNER will give final acceptance of the wiring system when all of the wiring is considered a complete system. All equipment shall function and operate in the proper manner as indicated in the details of the specifications and on the Drawings. All motors shall be properly connected to protective devices, and motor rotation shall be in the correct direction.
- D. At the request of OWNER's representative, demonstrate by test the compliance of the installation with these specifications and Drawings, the National Electrical Code, and the accepted standards of good workmanship. These tests shall include operation of equipment, continuity of the conduit system, grounding resistance and insulation resistance.
- E. A written record of performance tests on electrical and control and instrumentation systems and equipment shall be supplied to OWNER. Such tests shall show compliance with governing codes.

3.07 WIRE INSTALLATION SCHEDULE

- A. Install all wiring in raceways except as otherwise noted. This includes all low-voltage wiring such as temperature control, instruments, phone, network, fiber optic, etc.

END OF SECTION

SECTION 26 05 23

INSTRUMENT AND COMMUNICATION WIRE AND CABLE

PART 1—GENERAL

1.01 SUMMARY

- A. Work Included: This specification contains the requirements for instrument wire and cable as opposed to electrical power wire and cable.
- B. Related Sections and Divisions: Applicable provisions of Division 01 shall govern work in this section.

1.02 QUALITY ASSURANCE

- A. Standards: Comply with standards specified in this section as listed in Division 01.
- B. Qualifications of Installers: Workers who are thoroughly trained and experienced in the necessary crafts, and who are completely familiar with the specified requirements and the methods needed for proper performance of the work.

1.03 PRODUCT HANDLING

- A. Instrument cable shall be furnished in lengths as necessary.
- B. Reels, coils, or package rolls of instrument cable shall be identified with the project name and other tagging identification as called for.

1.04 SUBMITTALS

- A. Submit shop drawings and product data in accordance with provisions of Section 01 33 00—Submittals.
- B. Submit an electronic copy of the fiber optic cable testing report.
- C. Furnish three hard copies and one electronic copy of the final approved fiber optic cable test report to OWNER.

1.05 QUALIFICATIONS

- A. CONTRACTOR shall have at least 10 years of experience in the installation of similar systems. CONTRACTOR shall provide documentation upon request to certify that all assigned staff have attended training courses corresponding to the type of cabling and equipment specified herein.
- B. CONTRACTOR shall currently be licensed to install low voltage electronic cabling systems in the state of the project.

- C. CONTRACTOR shall currently meet all manufacturer's requirements for the provision and installation of all equipment specified herein.

PART 2–PRODUCTS

2.01 HEAT SHRINK TUBING FOR SHIELDED INSTRUMENT CABLES

- A. Heat shrink tubing for sealing the ends of all shielded instrument and current transformer cables shall be heavy-wall, low-voltage tubing as manufactured by Raychem Type WCSM, or equal.

PART 3–EXECUTION

3.01 INSTALLATION REQUIREMENTS AND SPECIAL CONSIDERATIONS

- A. Shielded pair specified in this section shall be installed in conduit, and may not be run in free-air or in nonmetallic tubing such as innerduct.
- B. Where circumstances prohibit underground installation of “emergency” or “critical” circuits, the lead wires and/or multipair cables shall conform to the appropriate sections of this specification, except they shall be armored and have an asbestos layer between the inner jacket and the armor to permit the wires to withstand an open-flame temperature of 1,700°F for a minimum of 20 minutes without interrupting the “critical” or “emergency” signals.

3.02 GROUNDING

- A. Shielded cabling shall be installed in accordance with manufacturer's instructions and to minimize electrical noise and interference to associated instruments. Refer to instrument manufacturer's instructions for additional requirements.
- B. Ends of signal wires shall be sealed to prevent the migration of moisture into the cable and to prevent unintentional grounding of the shield at the open end. Seal signal wires using a minimum 1-inch piece of heat-shrink tubing installed over PVC jacket and individual wires, and heat-shrink to a watertight fit.
- C. All shields must be grounded.
- D. Shields shall be grounded at one point only. Shielded cabling shall be isolated and left open at the instrument. The single-pair electronic instrument cable shields shall be connected to the multipair electronic instrument cable overall shield in the field junction box. The multipair electronic cable overall shield shall be grounded to the control room instrument ground.
- E. Cable shield grounds shall be isolated from control system signal grounds, except at instrument system grounding electrodes.
- F. The control room instrument ground shall be separate and isolated from the electrical power grounding system.

G. See grounding riser diagram in the Drawings for additional requirements.

END OF SECTION

SECTION 26 05 29
SUPPORTING DEVICES

PART 1–GENERAL

1.01 SUMMARY

- A. Work Included:
 - 1. Conduit and Equipment Support Members.
 - 2. Fastening Hardware.
- B. Related Sections and Divisions: Applicable provisions of Division 01 shall govern work in this section.

1.02 QUALITY ASSURANCE

- A. Support systems shall be adequate for weight of equipment and conduit, including wiring, which they carry.

1.03 SUBMITTALS

- A. Submit shop drawings and product data in accordance with provisions of Section 01 33 00–Submittals.

PART 2–PRODUCTS

2.01 MATERIAL

- A. Support Members:
 - 1. 316 stainless steel in exterior locations and damp and wet locations.
 - 2. Hot-dipped galvanized steel in all other areas.
- B. Hardware:
 - 1. 316 stainless steel in exterior locations and damp and wet locations.
 - 2. PVC-coated steel clamps and stainless steel hardware with 316 stainless steel members where used to support PVC-coated rigid steel conduits.
 - 3. Hot-dipped galvanized steel in all other areas.
- C. Manufacturers: Unistrut P-1000, B-line, Superstrut, or equal.

PART 3–EXECUTION

3.01 INSTALLATION

- A. All supporting devices and support structures shall be constructed such that the structure adequately supports the load of the equipment installed on it including any wind and/or snow loads.

- B. Fasten hanger rods, conduit clamps, and outlet and junction boxes to building structure using expansion anchors or support members. Do not use spring steel clips and clamps. Provide standoffs as specified in other technical sections.
- C. Use toggle bolts or hollow wall fasteners in hollow masonry, plaster, or gypsum board partitions and walls; expansion anchors or preset inserts in solid masonry walls; self-drilling anchors or expansion anchors on concrete surfaces; sheet metal screws in sheet metal studs; and wood screws in wood construction.
- D. The ends of all support members shall be ground smooth.
- E. Do not fasten supports to piping, ductwork, mechanical equipment, or conduit.
- F. Do not use powder-actuated anchors.
- G. Do not drill structural steel members.
- H. Fabricate supports with welded end caps and all welds and surfaces ground smooth for neat appearance. Use hexagon head bolts with steel spring-lock washers under all nuts.
- I. Install surface-mounted cabinets with a minimum of four anchors.
- J. Do not use chain, wire rope, or perforated strap hangers.
- K. All welds shall be continuous and ground smooth.

END OF SECTION

SECTION 26 05 33

CONDUIT

PART 1–GENERAL

1.01 SUMMARY

- A. Work Included:
 - 1. Rigid Metal Conduit and Fittings.
 - 2. Polyvinyl Chloride (PVC) Externally and Internally Coated Galvanized Rigid Metal Conduit and Fittings.
 - 3. PVC Conduit and Fittings.
 - 4. Liquidtight Flexible Conduit and Fittings.
 - 5. Conduit Seals and Special Fittings.
- B. Related Sections and Divisions: Applicable provisions of Division 01 shall govern work in this section.

1.02 REFERENCES

- A. ANSI C80.1–Electrical Rigid Steel Conduit (ERSC).
- B. ANSI/NEMA FB 1–Fittings, Cast Metal Boxes, and Conduit Bodies for Conduit, Electrical Metallic Tubing, and Cable.
- C. NEMA RN 1–Polyvinyl-Chloride (PVC) Externally Coated Galvanized Rigid Steel Conduit and Intermediate Metal.

1.03 QUALITY ASSURANCE

- A. Manufacturers of Raceways: Firms regularly engaged in the manufacture of electrical raceways of the types and capacities required whose products have been in satisfactory use in similar service for not less than 5 years.
- B. Installer: A firm with at least 5 years of successful installation experience on projects with electrical wiring installation work similar to that for the project.
- C. Code Compliance: Comply with National Electrical Code (NFPA 70) and any and all local codes as applicable to construction and installation of electrical wiring devices, material, and equipment herein specified.
- D. UL Labels: Provide electrical materials, which have been listed and labeled by Underwriters Laboratories.
- E. Prior to shipment to the site, all conduit provided shall be new, unused material, and shall not have been stored outdoors or exposed to weather.
- F. NECA Standard: Comply with applicable portions of National Electrical Contractor's Association's "Standard of Installation."

1.04 SUBMITTALS

- A. Submit shop drawings and product data in accordance with provisions of Section 01 33 00–Submittals.

1.05 PRODUCT DELIVERY, STORAGE, AND HANDLING

- A. Provide color-coded thread protectors on the exposed threads of threaded rigid metal conduit.
- B. Handle conduit carefully to prevent end damage and to avoid scoring the finish.
- C. Store conduit inside and protect from weather. When necessary to store outdoors, elevate well above grade and enclose with durable, waterproof wrapping.

PART 2–PRODUCTS

2.01 RIGID METAL CONDUIT AND FITTINGS

- A. Rigid Steel Conduit: ANSI C80.1 and UL6. Heavy wall seamless tubing with hot-dipped galvanized coating.
- B. Conduit bodies for rigid steel conduit shall be as manufactured by Appleton, Form 35, or equal, and be constructed of stamped steel for sizes 2 inches and under, and cast malleable iron for sizes over 2 inches. Conduit bodies shall have domed neoprene gasketed covers and stainless steel screws. Conduit bodies sizes 1 1/4-inch and larger shall have built-in pulling rollers. Covers for conduit bodies must have bolts that thread into the conduit body. Snaptight and wedgenut covers are not allowed. CONTRACTOR shall select body style and size according to application.
- C. PVC-coated conduit and fittings shall be internally and externally hot dipped galvanized rigid metal conduit with hot dipped galvanized threads and PVC coating. PVC coating shall be UL listed with rigid metal conduit as the primary means of corrosion protection for the conduit, and PVC coating shall have an external 40 mil thickness with an internal 2 mil urethane coating. Acceptable manufacturers shall be Plasti-bond RedH₂OT by Robroy Industries, Ocal-Blue by ABB (Thomas & Betts), Calbond, or equal. All installers shall be field-certified from the factory for installation and shall provide proof of certification. PVC-coated conduit and fittings shall meet the following listings and manufacturing standards, without exception:
 - 1. ANSI C80.1.
 - 2. UL6.
 - 3. NEMA RN1.
- D. Conduit bodies for PVC-coated rigid conduit shall be as manufactured by Plasti-bond RedH₂OT by Robroy Industries, Ocal-Blue by ABB (Thomas & Betts), Calbond, or equal, and have a 40 mil PVC exterior coating and 2 mil red urethane interior coating. Conduit bodies shall be Form 8 style or pulling elbow and include domed, gasketed covers and stainless steel screws. Covers for conduit bodies must have bolts that thread into the

conduit body. Snaptight and wedgenut covers are not allowed. CONTRACTOR shall select body style and size according to application.

- E. Fittings and Conduit Bodies: ANSI/NEMA FB 1 and UL 514B; threaded-type material to match conduit. For hazardous locations, fittings and conduit bodies shall meet the requirements of UL 886. Split couplings are not allowed.
- F. Supports: One-hole straps with conduit clamps and backspacers shall be used for surface-mounted conduit. Where standoffs are required, provide conduit clamps and supporting devices as specified in Section 26 05 29—Supporting Devices. One-hole straps with conduit clamps and backspacers for PVC-coated rigid steel conduit shall be PVC-coated rigid steel material.

2.02 PVC CONDUIT AND FITTINGS

- A. Conduit: Heavy wall rigid, Schedule 40, Schedule 80 where noted, UL listed for underground, encased, and aboveground applications. PVC conduit installed in exterior locations shall be UV resistant.
- B. Conduit bodies for PVC conduit shall be as manufactured by Carlon, or equal, and be suitable for use with Schedule 40 or Schedule 80 PVC conduit. Conduit bodies shall have smooth hubs, textured lids, and foam-in-place gaskets. CONTRACTOR shall select body style and size per application.
- C. Supports: Two-hole nonmetallic clamps shall be used for surface-mounted conduit. Where standoffs are required, provide pipe straps and supporting devices as specified in Section 26 05 29—Supporting Devices. Support material shall match that of the conduit type being provided.

2.03 LIQUIDTIGHT FLEXIBLE CONDUIT AND FITTINGS

- A. Liquidtight Flexible Metal Conduit:
 - 1. Conduit: Spiral-wound, electrogalvanized, single-strip steel with integral grounding conductor continuously enclosed within the entire length of the convolutions. The flexible PVC jacket shall be sunlight-resistant, flame-retardant, and resistant to damage from mild acids. Conduit shall be UL Listed. Conduit shall be Liqueflex Type LA, or equal.
 - 2. Fittings: UL listed with thermoplastic elastomer sealing gasket.
 - a. Provide stainless-steel fittings in exterior, and damp and wet locations, unless noted otherwise.
 - b. Provide electro-zinc plated steel fittings in all other areas, unless noted otherwise.

2.04 CONDUIT SEALS AND SPECIAL FITTINGS

- A. Conduit Seals: Duct sealing compound, OZ Gedney Type DUX, or equal.
- B. Expansion Fittings: Crouse Hinds or Robroy Type XJG (non-hazardous location) or Type UNY/UNF (hazardous location), or equal, for rigid, IMC, or PVC-coated rigid conduit. Carlon E945 Series, or equal for PVC conduit.
- C. Expansion Deflection Fittings: O-Z type "DX," Crouse Hinds, Type XD, or Appleton.

- D. Ground Bushings: Crouse Hinds Model GLL, or equal.
- E. Watertight Hubs: Diecast, insulated and gasketed, rated for wet or dry locations indoors or outdoors. Watertight hubs shall be Appleton HUBXXXDN, Crouse-Hinds Myers Hubs, or equal.
- F. Conduit Plugs: Kwik N Sure pipe plug as manufactured by Cherne Industries, or equal. Plug shall include natural rubber O-ring with galvanized wing nut and hex nut.
- G. Conduit Threads Joint Compound: Kopr-shield conductive, anti-corrosion joint compound as manufactured by Thomas & Betts, or equal.

PART 3–EXECUTION

3.01 CONDUIT SIZING, ARRANGEMENT, AND SUPPORT

- A. Size conduits for branch circuit conductors, control wires, and instrumentation cables so as to have not less than 25% spare capacity after installation; 3/4 inch minimum size. Minimum size for liquidtight flexible metal conduit is 1/2 inch.
- B. Maintain at least 1 inch of separation between conduit sizes to 1 1/2 inches and 2 inches between conduits 1 1/2 inches or larger. Maintain 1 foot of separation between signal conduits (below 100 volts) and power conduits (100 volts and above).
- C. All conduit shall be supported in accordance with the NEC and as specified herein. This shall apply to all conduit types, including flexible conduit.
- D. Provide for the proper application, installation, and location of inserts, supports, and anchor bolts for a satisfactory raceway system. Where any component of the raceway system is damaged, replace or provide new raceway system.
- E. Run conduits concealed to avoid adverse conditions such as heat and moisture, to permit drainage, and to avoid all materials and equipment of other trades. Maintain a minimum clearance of 6 inches from all hot water pipes, flues, or any high-temperature piping or ductwork.
- F. Conduits shall be attached to building surfaces and not suspended unless installed in a Unistrut-type conduit rack as specified herein. Individual conduits shall not be suspended. Clevis hangers are not allowed.
- G. Independently support or attach the raceway system to structural parts of construction in accordance with good industry practice.
- H. Conduit attached to building surfaces that may be damp or wet shall be spaced out to avoid rust and/or corrosion using fittings approved for the use. Use back straps on all conduit in damp and wet locations, or mount conduit with Unistrut straps, or equal. Watertight hubs shall be used in all damp and wet locations.
- I. Conduits shall be securely fastened to building structure at intervals not exceeding 8 feet or closer, if necessary. Where hangers are necessary, 3/8-inch rod/eyelets/rings/or trapeze

type in Unistrut channel and pipe clamps shall be used. Wire or perforated strap iron is not acceptable.

3.02 GENERAL CONDUIT INSTALLATION REQUIREMENTS

- A. Interior conduit shall be run concealed in walls, building cavities, chases, and buried below floor slabs. Concealed conduit shall be run within block walls and may not be run between the block and brick facing. Exterior conduit shall be buried below grade and concealed in structure walls. Exposed conduit runs shall be avoided. Conduit may be run exposed only where it is impossible to conceal.
- B. All conduit installed below grade shall be buried a minimum of 2 feet 0 inches. All conduit installed below floor slabs shall be buried a minimum of 1 foot below slab.
- C. PVC-coated rigid steel conduit and PVC conduit installed in earth (interior and exterior) shall be bedded in compacted sand with a minimum of 6-inch cover on all sides.
- D. Ream conduit smooth at ends, cap upon installation, rigidly attach to structural parts of the building, and securely fasten to all outlet boxes, panel cabinets, junction boxes, pull boxes, splicing chambers, disconnect switches, and all other components of the raceway system.
- E. Provide conduit raceway for exposed cables that are not UV resistant. This shall include, but not be limited to, instrument wiring, motor terminators, etc.
- F. Conduit seals shall be provided where conduits pass from the interior to exterior of the building.
- G. Liquidtight flexible conduit shall be installed in such a manner that liquids tend to run off the surfaces and not drain toward the fittings.
- H. All runs of flexible conduit and flexible conduit couplings to equipment and devices shall be as short as practicable, of the same size as the conduit it extends, and with enough slack to reduce the effects of vibration to a minimum. A minimum of 18 inches of flexible conduit shall be installed for each motor.
- I. Provide conduit expansion-deflection fittings as specified herein in all conduit runs where movement perpendicular to axis of conduit may be encountered.
- J. Conduits shall be pitched so that drainage is away from all structures.
- K. Conduit bends for PVC conduit shall be made using a hot box, heat blanket, or glycol bender. Open flame or point heat sources of any type are not allowed.
- L. The PVC-coated rigid conduit manufacturer's touch-up compound shall be used on all conduit interior and exterior bare steel exposed because of nicks, cuts, abrasions, thread cutting, and reaming; minimum six coats.
- M. Where below-grade PVC conduit is connected to rigid metal conduit, the length of PVC conduit shall be a minimum of 10 feet. For short, below-grade conduit runs where required lengths of rigid metal conduit limit the length of PVC conduit to less than 10 feet, rigid metal conduit shall be used for the entire run.

- N. Routing of conduits on exterior of buildings shall be avoided to the extent possible and shall not cover or interfere with lighting, signage, windows, louvers, or other openings. All conduit routing on exterior walls shall be reviewed with ENGINEER for approval prior to installation.
- O. Conduits installed in damp and wet locations shall have all threads coated with conduit threads joint compound.

3.03 CONDUIT PENETRATIONS AND TERMINATIONS

- A. Where fittings are brought into an enclosure with a knockout, a gasket assembly consisting of an O-ring and retainer shall be installed on the outside. Fittings shall be insulated throat type.
- B. Conduit penetrations for control panels or enclosures containing electronic equipment shall utilize watertight hubs and, if entering the top of the enclosure, shall be located at the front of the enclosure and not over any electronic equipment (e.g., PLC, power supplies, etc.).
- C. Conduit penetrations for all exterior enclosures (e.g., disconnects, junction boxes, control panels) shall utilize watertight hubs and enter the sides or bottom of the enclosure. Conduits shall not penetrate the top of the enclosure.
- D. Provide conduit expansion fittings as specified herein in all conduit runs that cross a structural expansion joint, for conduits protruding from duct banks that are routed above grade and into structures, and for conduits protruding from earth.
- E. All conduits that protrude from poured concrete shall be PVC-coated rigid conduit. Conduit shall extend continuously (i.e., no joints) a minimum of 4 feet beyond the poured concrete (both sides). Where an underground conduit joint or coupling is located within 4 feet of the face of the penetration, the conduit shall be provided with reinforced concrete encasement doweled into the structure wall and continuing a minimum of 1 foot past the connection. The encasement construction shall conform with the encasements indicated for duct banks. PVC-coated rigid conduit 4-foot minimum projection requirement shall begin at, and extend from, the end of the encasement. The intent of this paragraph is to permit CONTRACTOR to use couplings at the inside face of the formwork.
- F. Conduits passing through masonry, concrete, or similar construction shall be cast in place using PVC-coated rigid conduit extending completely through the construction.
- G. Where above-grade conduits pass through cores in existing structures or through masonry walls, grout openings between conduit and walls or floors with sand cement mortar.
- H. All spare conduits shall be plugged with conduit plugs as specified herein.

3.04 CONDUIT INSTALLATION SCHEDULE

- A. The following schedule lists specific conduit types allowed in designated areas. Those areas not listed under a specific conduit type shall not have that type of conduit installed:
 - 1. Rigid steel: All interior locations.
 - 2. PVC-coated rigid steel:
 - a. Conduits protruding from concrete.
 - b. Earth.

- c. Within 4 feet of a manhole/handhole or building/structure footing or wall.
 - d. Exterior locations and locations exposed to weather.
3. PVC:
- a. Earth, except conduits within 4 feet of a building/structure footing or wall. PVC conduit under pavement or roadways shall be Schedule 80.
 - b. Buried below slabs on grade.
4. Liquidtight flexible metal conduit not over 3 feet in length for final connections to equipment with sliding bases or flexible positioning.

END OF SECTION

SECTION 26 05 35

BOXES

PART 1–GENERAL

1.01 SUMMARY

- A. Work Included:
 - 1. Outlet and Small Junction Boxes.
 - 2. Pull and Junction Boxes.
- B. Related Sections and Divisions: Applicable provisions of Division 01 shall govern Work in this section.

1.02 REFERENCES

- A. ANSI/NEMA OS 1–Sheet-Steel Outlet Boxes, Device Boxes, Covers, and Box Supports.
- B. ANSI/NEMA OS 2–Nonmetallic Outlet Boxes, Device Boxes, Covers, and Box Supports.
- C. NEMA 250–Enclosures for Electrical Equipment (1000 Volts Maximum).

1.03 QUALITY ASSURANCE

- A. Manufacturers of switches, outlets, boxes, lamps, fuses, lugs, etc.: Firms regularly engaged in the manufacture of these products, of the types and ratings required, whose products have been in satisfactory use in similar service for not less than 5 years.
- B. Installer: A firm with at least 5 years of successful installation experience on projects with electrical wiring installation Work similar to that in this project.
- C. Code Compliance: Comply with National Electrical Code (NFPA 70) and any and all local codes as applicable to construction and installation of electrical wiring devices, material, and equipment herein specified.
- D. UL Labels: Provide electrical cable, boxes, raceways, wire, connectors, outlets, switches, etc. that have been listed and labeled by Underwriters Laboratories.
- E. NECA Standard: Comply with applicable portions of National Electrical Contractor's Association's "Standard of Installation."

1.04 SUBMITTALS

- A. Submit shop drawings and product data in accordance with provisions of Section 01 33 00–Submittals.

PART 2–PRODUCTS

2.01 OUTLET AND SMALL JUNCTION BOXES

- A. NEMA 4X Boxes:
 - 1. Outlet Boxes: PVC or FRP, Carlon FD Series, or equal with proper cover and gasket. 316 stainless steel, Calbrite FDC Series, or equal where specified herein.
 - 2. Small Junction Boxes: PVC or FRP, Carlon HS Series, or equal with proper cover and gasket.
- B. Covers for junction boxes shall have covers that match box type.

2.02 PULL AND JUNCTION BOXES

- A. NEMA 4X Boxes: Boxes shall be 316 stainless steel with hinged cover, recessed quarter-turn padlocking latches, and gasket, Saginaw Control and Engineering Enviroline Series, or equal, where specified herein.
- B. NEMA 12 Boxes: Painted steel with hinged cover, recessed quarter-turn padlocking latches, gasket, and locking system. Boxes shall be Hoffman CSD, or equal.
- C. Boxes specified in this section are not allowed to have knockouts and are not allowed to be used as enclosures for control panels.

PART 3–EXECUTION

3.01 COORDINATION OF BOX LOCATIONS

- A. Provide electrical boxes as necessary for splices, taps, wire pulling, cable bending radii, equipment connections, and code compliance.
- B. Verify location and size of outlet boxes in all work areas prior to rough-in.
- C. Where dedicated raceways are provided for different voltage systems or wiring, (e.g., motor power wiring and motor space heaters), separate boxes shall also be provided unless acceptable to ENGINEER. Where acceptable to ENGINEER, combined boxes shall be physically divided to separate the wiring.
- D. Locate and install boxes to allow access. Where installation is inaccessible, coordinate locations and sizes of access doors.
- E. Locate and install to maintain headroom and to present a neat appearance.
- F. All boxes attached to building surfaces that may be damp or wet shall be spaced to avoid rust and/or corrosion. All boxes in damp and wet locations shall be on 1/2-inch standoffs.

3.02 OUTLET AND SMALL JUNCTION BOX INSTALLATION

- A. Support boxes independently of conduit.

- B. Use multiple gang boxes where more than one device is mounted together; do not use sectional boxes. Provide barriers to separate wiring of different voltage systems.
- C. Outlet boxes provided for branch circuits and feeders shall not contain control wiring. Control wiring shall have dedicated pull and junction boxes provided. Wiring for different voltage systems (e.g., 24 V, 120 V, 480 V) shall have dedicated pull and junction boxes for each voltage.
- D. Knockout punches or saws shall be used for holes; boxes with prepunched holes are not acceptable.
- E. Boxes shall be of a depth to accommodate wires and splices.

3.03 PULL AND JUNCTION BOX INSTALLATION

- A. Support pull and junction boxes independent of conduit.
- B. Knockout punches or saws shall be used for holes; boxes with prepunched holes are not acceptable.
- C. Refer to Section 26 05 53—Electrical Identification for junction box labeling requirements.
- D. All interior boxes shall be NEMA 12, unless noted otherwise.
- E. All exterior boxes shall be NEMA 4X.

END OF SECTION

SECTION 26 05 53

ELECTRICAL IDENTIFICATION

PART 1–GENERAL

1.01 SUMMARY

- A. Work Included:
 - 1. Nameplates.
 - 2. Labeling Tags.
 - 3. Wire and Cable Markers.
- B. Related Sections and Divisions: Applicable provisions of Division 01 shall govern work in this section.

1.02 SUBMITTALS

- A. Submit shop drawings and product data in accordance with provisions of Section 01 33 00–Submittals.
- B. Provide schedule for nameplates and labeling tags with shop drawings. Reference Drawings for type used.

PART 2–PRODUCTS

2.01 NAMEPLATES

- A. Nameplate material shall be multi-color, two-layer, nonconductive engraving plastic suitable for permanent installations in indoor and outdoor locations. The material shall be UV-resistant and suitable for installation in direct sunlight.
- B. Type “A”:
 - 1. Use:
 - a. Each separately mounted circuit breaker or disconnect switch.
 - b. Cabinets, enclosures, pull, and junction boxes.
 - 2. Size: 2 inches by 4 inches.
 - 3. Background Color: Black.
 - 4. Character Color: White.
 - 5. Character Size: 1/2-inch.
 - 6. Engraving: See MCC schedule, one-line, and I/O list for labels, or as requested by ENGINEER. Label shall include equipment number and description (i.e., SCAL-60-01, Fluoride Scale).
 - 7. Mounting Location: Front exterior.
- C. Type “B”:
 - 1. Use:
 - a. Standby power systems.
 - b. Automatic Transfer Switches.
 - 2. Size: 2 inches by 4 inches.

3. Background Color: Red.
4. Character Color: White.
5. Character Size: 1/4-inch.
6. Engraving: See MCC schedule and one-line for labels, or as requested by ENGINEER.
7. Mounting Location: As requested by ENGINEER.

D. Type "C":

1. Use:
 - a. Electrical Distribution System Equipment not previously specified.
 - b. Operator Instructions.
2. Size: As necessary.
3. Background Color: Yellow.
4. Character Color: Black.
5. Character Size: 1/4-inch.
6. Engraving and Mounting Location: As requested by ENGINEER.

2.02 LABELING TAGS

- A. Labeling tag material shall be multi-color, 2-layer, nonconductive engraving plastic suitable for permanent installations in indoor and outdoor locations. The material shall be UV-resistant and suitable for installation in direct sunlight.
- B. Use: Field-mounted devices without surfaces suitable for mounting fixed nameplates (Valves, Limit Switches, Level Transmitters, Flow Transmitters, etc.).
 1. Size: 3/8-inch by 2 inches.
 2. Character Size: 1/4-inch.
 3. Engraving: As requested by ENGINEER.

2.03 WIRE AND CABLE MARKERS

- A. Wire and cable markers shall be permanently-attached, heat-shrink type labels.
 1. Sleeve: Permanent, PVC, white, with legible machine-printed black markings.
 2. Acceptable Manufacturers: Raychem Model D-SCE or ZH-SCE, Brady Model 3PS, or equal.
 3. Grounding Conductor: Provide green wire marker; minimum 2 inches wide.
- B. Wire or cable numbering preprinted on the conductor or cable insulation, flag-type labels, and individual wraparound numbers (such as Brady preprinted markers) are not acceptable. All permanently-attached, heat-shrink type wire markers shall be the same throughout the project.
- C. Wire and cable markers provided within control panels, motor control panels, motor control centers, and electrical enclosures by equipment manufacturer or enclosure fabricator on in-factory installed wiring shall be laminated, wrap-around type labels. Wire and cable markers provided outside of the fabrication factory shall be permanently-attached, heat-shrink type labels as specified above.

PART 3–EXECUTION

3.01 INSTALLATION

- A. Degrease and clean surfaces to receive nameplates.
- B. Install nameplates parallel to equipment lines.
- C. Affix nameplates with weatherproof, UV-resistant adhesive in outdoor locations and sticky back adhesive in indoor locations.
- D. Affix labeling tags with stainless steel leaders; vinyl locking wire ties are not acceptable. Provide 3/8-inch hole to accommodate wire tie.
- E. Prepare and install neatly-typed circuit directories and schedules in all panels, including, but not limited to, existing panels where Work is done under this Contract.
- F. Labeling tags shall only be used for equipment enclosures without surfaces suitable for mounting fixed nameplates.

3.02 WIRE IDENTIFICATION

- A. Provide wire markers on each conductor, including neutral and spare conductors, in panelboard gutters, pull boxes, outlet and junction boxes, and at load connection. Neutral conductor labels shall include the associated branch circuit number. Identify with branch circuit or feeder number for power and lighting circuits, and with control wire number as indicated on schematic and interconnection diagrams for control wiring. Spare conductors shall have control wire number or shall indicate termination point of wire.
- B. Conductors in pull boxes, supervisory control panels, control panels, cabinets, and panelboards shall be grouped as to circuits and arranged in a neat manner. All conductors of a feeder or branch circuit shall be grouped, bound together with nylon ties, and identified. Phase identification shall be consistent throughout the system. All wiring labels shall be able to be read without removing wire management (i.e., wiring trough covers, spiral windings, etc.) or twisting the wire/cable.
- C. Power Conductor Insulation Color Code:
 - 1. 6 AWG and Larger: Provide general-purpose, flame-retardant, permanent tape at each termination and at accessible locations such as manholes, handholes, junction and pull boxes, panelboards, motor control centers, switchboards, switchgear, etc. Apply tape with at least six full, overlapping wraps; minimum 2 inches wide.
 - 2. 8 AWG and Smaller: Provide conductors with color-coded insulation.
 - 3. Colors:

System	Conductor	Color
All Systems	Equipment Grounding	Green
120/240 Volts Single-Phase, Three-Wire	Grounded Neutral	White*
	One Hot Leg	Black
	Other Hot Leg	Red

System	Conductor	Color
120/208 Volts Three-Phase, Four-Wire	Grounded Neutral Phase A Phase B Phase C	White* Black Red Blue
277/480 Volts Three-Phase, Four-Wire	Grounded Neutral Phase A Phase B Phase C	White* Brown Orange Yellow
Note: Phase A, B, C implies direction of positive phase rotation.		
* When installed as part of a 120-volt or 277-volt branch circuit, provide a color-coded stripe on the white neutral conductor insulation matching the branch circuit insulation.		

- D. Control Panel and Field-Installed Control Conductor Insulation Color Code:
1. All conductors shall have color-coded insulation.
 2. Colors:

System	Conductor	Color
Supply Voltage	Ungrounded Circuit Conductors Neutral	Black White
Discrete 120-volt AC Input/Output	Control Circuit Conductor Neutral	Red White
Discrete 12/24-volt DC Input/Output	Control Circuit Conductor Common	Blue White with Blue Stripe
Conductors energized when the main disconnect is in the "off" position (e.g., foreign supply voltages)	Control Circuit Conductor AC Neutral DC Common Ground	Orange White White with Blue Stripe Green

- E. Circuit Identification:
1. Identify power, instrumentation, and control conductors at each termination and at accessible locations such as junction and pull boxes, panelboards, etc.
 2. Conductors for panelboard circuits shall identify circuit matching the circuit directory designations, including the neutral conductor.
 3. Control conductor identification shall match the associated terminal block label.
 4. Circuits Not Listed in Circuit Directories:
 - a. Assign circuit name based on unique device or equipment at load end of circuit.
 - b. Where unique device or equipment names are not available or apparent, add a unique number or letter modifier to each otherwise identical circuit name.

3.03 JUNCTION BOX IDENTIFICATION

- A. All junction boxes shall be labeled with permanent nameplates. Nameplates shall indicate circuit or load served, as well as the power source and highest voltage present on any conductor.

3.04 CONDUIT FITTINGS IDENTIFICATION

- A. All conduit fittings that contain splices of any kind shall be labeled with permanent nameplates indicating "splice within." Nameplates shall be clearly visible at location installed. Nameplates shall be fastened to each conduit fitting with heavy duty, UV-resistant, cold weather cable ties.

3.05 TERMINAL BLOCK IDENTIFICATION

- A. Terminal blocks shall be labeled on both sides of each terminal block. Terminal block numbering shall match the numbers shown on the project-specific wiring diagrams.
- B. Fused terminal blocks labels shall be located on top of the terminal blocks and include the fuse voltage and ampere rating.

3.06 COMPONENT IDENTIFICATION

- A. All components (e.g., relays, timers, power supplies, transformers, etc.) within enclosures shall be identified with sticky-back adhesive, self-laminating, machine-printed marking labels. Labels shall be installed on the enclosure back panel and not on the device itself, wireway covers, or any other removable devices. Labels shall be included on the as-built drawings.

3.07 LABELING FONT REQUIREMENTS

- A. The font for all conductor, cable, and device labels shall be Arial with black characters on white background, and minimum font size 12.
- B. The text for all conductor, cable, and device labels shall be machine printed. Handwritten labels are not acceptable.

END OF SECTION

SCADA SYSTEM I/O LISTING

STRAND ASSOCIATES, INC.®
VILLAGE OF OSWEGO
OSWEGO, IL
BOOSTER STATION BACKUP GENERATORS
CONTRACT 2-2026
SCADA SYSTEM I/O LISTING - SCC-3

SCC	EQUIPMENT NAME	NUMBER	DI	DO	AI	AO	WIRE	COMMENTS
3	AUTOMATIC TRANSFER SWITCH	SE-ATS-03						
3	IN NORMAL POSITION		1	0	0	0	2-#14	FROM AUTOMATIC TRANSFER SWITCH
3	IN STANDBY POSITION		1	0	0	0	2-#14	FROM AUTOMATIC TRANSFER SWITCH
3	STANDBY GENERATOR							
3	RUNNING		1	0	0	0	2-#14	FROM GENERATOR CONTROL PANEL
3	FAILED		1	0	0	0	2-#14	FROM GENERATOR CONTROL PANEL
3	BATTERY CHARGER FAILED		1	0	0	0	2-#14	FROM GENERATOR CONTROL PANEL
3	REMOTE E-STOP ACTIVATED	CS-03-01	1	0	0	0	2-#14	FROM REMOTE EMERGENCY STOP PUSHBUTTON
	TOTALS		6	0	0	0		

SECTION 26 28 00

OVERCURRENT PROTECTIVE DEVICES

PART 1–GENERAL

1.01 SUMMARY

- A. Work Included: Provide overcurrent protective devices as shown on the Drawings, as specified herein, and as needed for a complete and proper installation.
- B. Related Sections and Divisions: Applicable provisions of Division 01 shall govern work in this section.

1.02 SUBMITTALS

- A. Submit shop Drawings and product data in accordance with provisions of Section 01 33 00–Submittals, including electrical ratings, physical size, interrupt ratings, trip curves, I²t curves, and manufacturer’s detailed specifications.

1.03 QUALITY ASSURANCE

- A. Comply with the following requirements:
 - 1. NFPA 70 National Electrical Code (NEC).
 - 2. Local codes and ordinances.
 - 3. Provide overcurrent protective devices by same manufacturer for each type of device.

1.04 DELIVERY, STORAGE, AND HANDLING

- A. Comply with pertinent provisions of Section 01 60 00–Materials and Equipment.
- B. Store in a clean, dry space. Maintain factory wrapping or provide an additional heavy canvas or heavy plastic cover to protect units from dirt, water, construction debris, and traffic.

PART 2–PRODUCTS

2.01 CIRCUIT BREAKERS

- A. General:
 - 1. Comply with UL 489 requirements.
 - 2. Provide thermal and magnetic protection unless noted otherwise.
- B. Feeder Breakers:
 - 1. Circuit breakers shall have a short-circuit interrupting rating as indicated on the Drawings.
 - 2. Solid-State Circuit Breakers: Circuit breakers supplied with the portable generators for supply of customer load shall be provided with an integral LED ammeter, electronic sensing, timing, and tripping circuits with adjustable settings. Provide adjustable

long-time pickup, long-time delay, short-time pickup, short-time delay, and instantaneous pickup settings.

C. All lugs shall be rated to accept copper conductors.

2.02 ACCESSORIES

A. Provide accessories as listed below:

1. Handle Lock: Include provisions for padlocking.
2. Mechanical trip device.
3. Removable and sealable cover over the trip setting adjusting means for solid-state breakers with tamper-evident wire cable seal.

PART 3-EXECUTION

3.01 INSTALLATION

A. Install overcurrent protective devices in accordance with manufacturer's recommendations.

3.02 ADJUSTMENT

A. Set and record adjustable settings on circuit breakers to provide selective coordination and proper operation.

END OF SECTION

SECTION 26 32 13.1

STANDBY POWER SYSTEM

PART 1–GENERAL

1.01 SUMMARY

- A. Work Included: Steel base assembly, natural gas engine, generator, engine-generator set controls, environmental systems.
- B. Related Sections and Divisions:
 - 1. Applicable provisions of Division 01 shall govern work in this section.
 - 2. The following listing of related sections is provided for the convenience of CONTRACTOR and is not necessarily all-inclusive. Other sections of the specifications not referenced below shall also apply to the extent required for proper performance of this work. All other sections of Division 26.

1.02 SUBMITTALS

- A. Submit shop drawings and product data in accordance with provisions of Section 01 33 00–Submittals.
- B. Shop drawings shall include the following:
 - 1. Detailed descriptions of equipment to be furnished, including all deviations from these specifications.
 - 2. Detailed layouts of all equipment and ancillary items.
 - 3. The manufacturer shall furnish schematic and wiring diagrams for the generator and an interconnection wiring diagram for the entire standby system. Test reports certified by the manufacturer shall be provided to ENGINEER for the entire system.

1.03 QUALITY ASSURANCE

- A. The generator shall be listed by Underwriters Laboratories, Inc., UL2200, and be certified by the Canadian Standards Association.

1.04 OPERATING CONDITIONS

- A. Engine-generator set shall be capable of continuous standby rating at 1,800 rpm, 0.8 PF, three-phase, 4-wire, 480 volts, at 60 hertz, and shall have a minimum capability of 125 kW, 156 kVA standby. See additional voltage output requirements specifier herein.
- B. The generator set manufacturer shall verify the engine is capable of driving the generator with all accessories in place and operating, at the generator set kW rating after derating for the range of temperature expected in service, and the altitude of the installation. Site conditions are 120°F maximum ambient and 685 feet altitude.
- C. Voltage regulation shall be $\pm 0.5\%$ of rated voltage for any constant load between no load and rated load.

- D. Frequency regulation shall be isochronous from steady state no load to steady state rated load. Random frequency variation with any steady load from no load to full load shall not exceed $\pm 0.5\%$.
- E. Random Voltage Variation: The cyclic variations in RMS voltage shall not exceed $\pm 0.5\%$ of rated voltage for constant loads from no load to rated load, with constant ambient and operating temperature.
- F. Total Harmonic Distortion: The sum of AC voltage wave-form harmonics shall meet NEMA MG1 and shall not exceed 5% of rated voltage (L-N, L-L, L-L-L), and no single harmonic shall exceed 3% of rated voltage.
- G. Telephone Influence Factor shall be less than 50 per NEMA MG1-22.43.
- H. The engine-generator set shall accept a single step load of 100% nameplate kW and power factor, less applicable derating factors, with the engine-generator set at operating temperature.
- I. Motor starting capability shall be a minimum of 336 kVA. The generator set shall be capable of recovering to a minimum of 90% of rated no load voltage following the application of the specified kVA load at near zero power factor applied to the generator set. Maximum voltage dip on application of this load, considering both alternator performance and engine speed changes shall not exceed 25%.

1.05 WARRANTY

- A. Standard One-Year Warranty: Unless otherwise stated below, manufacturer shall warrant the equipment to be free from defects in material and workmanship for a period of one year from the earlier of either the date established for partial utilization in accordance with the Contract Documents or Substantial Completion of the project.

PART 2-PRODUCTS

2.01 ACCEPTABLE MANUFACTURERS

- A. The AC engine-generator set shall be as manufactured by Caterpillar Model DG125, Cummins Power Generation Model C125NG, or equal.
- B. The Drawings and Specifications were prepared based on Caterpillar with a maximum single-step voltage dip less than 15%. CONTRACTOR shall include in the Bid and shall be responsible for the cost of any changes to accommodate other equipment including, but not limited to, structural, mechanical, and electrical work. CONTRACTOR shall also pay additional costs necessary for revisions of Drawings and/or Specifications by ENGINEER.

2.02 STEEL BASE ASSEMBLY

- A. The engine-generator set shall be mounted on a heavy-duty steel base to maintain alignment between components. The base shall incorporate a battery tray with hold-down clamps within the rails.

2.03 ENGINE

- A. The engine shall be stationary, liquid-cooled, natural gas for use with natural gas fuel. The design shall be 4-cycle, 6-cylinder, minimum displacement of 543 cubic inches, turbo charged, and after cooled as required by engine manufacturer. Engine shall be certified as capable of driving the generator of the rating indicated above on a continuous standby basis for the duration of normal source interruptions.
- B. Engine accessories shall include the following:
1. A 12-volt DC electric starter as required by the engine manufacturer.
 2. Replaceable dry element air cleaner with restriction indicator.
 3. Positive displacement, mechanical, full-pressure lubrication oil pump, full-flow lubrication oil filters with replaceable elements, pressure relief valve, dipstick oil level indicator, and oil drain valve with hose extension. Provide all lubricants for proper operation of the unit.
 4. An electronic governor system shall provide automatic isochronous frequency regulation. The governing system dynamic capabilities shall be controlled as a function of engine coolant temperature to provide fast, stable operation at varying engine operating temperature conditions. The control system shall actively control the fuel rate and excitation as appropriate to the state of the generator set. Fuel rate shall be regulated as a function of starting, accelerating to start disconnect speed, and accelerating to rated speed.
 5. Engine protective devices to indicate alarm and engine shutdown for the following:
 - a. Low coolant temperature alarm.
 - b. Low coolant level alarm.
 - c. Low lubrication oil pressure alarm and shutdown.
 - d. High coolant temperature alarm and shutdown.
 - e. Over-speed shutdown.
 - f. Over-crank shutdown.
 6. Battery charging alternator, 100 amp minimum, with solid-state voltage regulator.
 7. Engine shall be radiator-cooled by engine-mounted radiator system including belt-driven pusher fan, coolant pump, and thermostat temperature control. Rotating parts shall be guarded against accidental contact. The cooling system shall be rated for full-rated load operation in a 104°F ambient condition. Provide radiator drain extension to the side of the generator. Extension shall include shutoff valve.
 8. The equipment supplier shall provide 50% ethylene glycol antifreeze solution to fill engine cooling system.
 9. Engine-mounted thermostatically controlled coolant heater to aid in quick starting. The coolant heater(s) shall be sized as recommended by the engine manufacturer to warm the engine to a minimum of 120°F in a 50°F ambient, in compliance with NFPA 110 requirements. Heater shall be rated single-phase, 120 volts, 1,800 watts and be disconnected whenever the engine starts. Heater shall be UL 499 listed and labeled. The coolant heater(s) shall include provisions to isolate the heater for replacement of the heater element without draining the coolant from the generator set.
 10. Vibration isolators, spring/pad type, quantity as recommended by the generator set manufacturer.
 11. Provide a 120-watt, 120 VAC oil breather heater for generators located outdoors.

2.04 ENGINE EXHAUST SYSTEM

- A. For natural gas generators rated 150 kW standby and smaller, engine emissions shall meet current Environmental Protection Agency (EPA) NSPS gas engine emission regulations.

Engines shall be EPA-certified and emission approval documentation shall be provided to OWNER prior to final completion. All costs associated with any on-site EPA-required emissions testing shall be included in the Bid.

- B. Exhaust muffler shall be provided for the engine of size as recommended by manufacturer. Muffler shall be of the critical grade-type. Exhaust inlet location shall be selected by CONTRACTOR. Coordinate with Division 23 based on actual installation and project conditions.
- C. Stainless steel flexible exhaust connections shall be provided as required for connection between engine exhaust manifold and exhaust line in compliance with applicable codes and regulations.
- D. Provide an exhaust condensation trap with manual drain valve to trap and drain off exhaust condensation to prevent condensation from entering the engine.
- E. Provide a suitable rain cap at the stack outlet. Provide all necessary flanges and special fittings for proper installation.

2.05 BATTERY CHARGER

- A. A UL-listed/CSA-certified 10-ampere voltage regulated battery charger shall be provided for the engine-generator set.
- B. Charger shall be UL 1236-BBHH listed and CSA or CUL certified for use in emergency applications.
- C. The charger shall be compliant with UL 991 requirements for vibration resistance.
- D. The charger shall be capable of charging a fully discharged battery without damage to the charger. It shall be capable of returning a fully discharged battery to fully charged condition within 24 hours. The charger shall be UL labeled with the maximum battery amp-hour rating that can be recharged within 24 hours. The label shall indicate that the charger is suitable for charging of 200 AH batteries in accordance with NFPA requirements.
- E. The charger shall incorporate a 4-rate charging algorithm, to provide trickle charge rate to restore fully discharged batteries, a bulk charge rate to provide fastest possible recharge after normal discharge, an absorption state to return the battery to 100% of charge, and a float stage to maintain a fully charged battery and supply battery loads when the generator set is not operating. In addition, the charger shall include an equalization timer. Charge rates shall be temperature compensated based on the temperature directly sensed at the battery.
- F. The DC output voltage regulation shall be within $\pm 1\%$. The DC output ripple current shall not exceed 1 amp at rated output current level.
- G. The charger shall include the following features:
 - 1. Two-line alphanumeric display with programming keys to allow display of DC output ammeter and voltmeters (5% accuracy or better), display alarm messages, and perform programming.
 - 2. LED indicating lamps to indicate normal charging (green), equalize charge state (amber), and fault condition (red).
 - 3. AC input overcurrent, over voltage, and under voltage protection.

4. DC output overcurrent protection.
5. Alarm output relay.
6. Corrosive-resistant aluminum enclosure.

2.06 STARTING AND CONTROL BATTERIES

- A. A calcium/lead antimony storage battery set of the heavy-duty starting-type shall be provided. Battery voltage shall be compatible with starting system. The battery set shall be rated no less than 850 CCA and shall be capable of a minimum of three 15-second cranking cycles. A battery rack constructed in conformance with NEC requirements and necessary cables and clamps shall be provided.

2.07 GENERATOR

- A. The generator shall be a single prelubricated bearing, self-aligning, 4-pole, two-thirds pitch, brushless, synchronous-type, revolving field with amortisseur windings, and with direct driven centrifugal blower fan for proper cooling and minimum noise. No brushes will be allowed. Generator shall be directly connected to engine fly wheel housing and driven through a flexible coupling to provide permanent alignment. Generator design shall prevent potentially damaging shaft currents.
- B. Insulation shall meet NEMA standards for Class H and shall be UL 1446 listed. The maximum temperature rise shall not exceed 120°C at 40°C ambient.
- C. The generator set shall be capable of delivering rated output (kVA) at rated frequency and power factor, at any voltage not more than 5% above or below rated voltage.
- D. Generators shall utilize a permanent magnet generator (PMG) to provide a reliable source of excitation power for optimum motor starting and short circuit performance. The PMG and controls shall be capable of sustaining and regulating current supplied to a single-phase or three-phase fault at approximately 300% of rated current for not more than 10 seconds.
- E. The subtransient reactance of the alternator shall not exceed 15%, based on the standby rating of the generator set.
- F. Provide a 200-amp mainline circuit breaker with the engine-generator set. Circuit breaker shall meet the requirements specified in Section 26 28 00—Overcurrent Protective Devices.

2.08 ENGINE-GENERATOR SET CONTROL

- A. The generator set shall be provided with a microprocessor-based control system that is designed to provide automatic starting, monitoring, and control functions for the generator set. The control system shall also be designed to allow local monitoring and control of the generator set, and remote monitoring and control as described in this specification.
- B. The generator set-mounted controls shall include the following features and functions for control switches:
 1. Mode Select Switch: The mode select switch shall initiate the following control modes. When in the RUN or MANUAL position the generator set shall start, and accelerate to rated speed and voltage. In the OFF position the generator set shall immediately stop, bypassing all time delays. In the AUTO position the generator set shall be ready to accept a signal from a remote device to start and accelerate to rated speed and voltage.

2. EMERGENCY STOP switch: Switch shall be Red “mushroom-head” pushbutton. Depressing the emergency stop switch shall cause the generator set to immediately shut down and be locked out from automatic restarting.
 3. RESET switch: The RESET switch shall be used to clear a fault and allow restarting the generator set after it has shut down for any fault condition.
- C. Generator Set AC Output Metering: The generator set shall be provided with a metering set including the following features and functions:
1. Digital metering set, 1% accuracy, to indicate generator RMS voltage and current (all three phases), frequency, output current, output kW, kWh, and power factor. Generator output voltage shall be available in line-to-line and line-to-neutral voltages, and shall display all three-phase voltages (line to neutral or line to line) simultaneously.
 2. The control system shall log total number of operating hours and total kWh, as well as total values since reset.
- D. Generator Set Alarm and Status Display: The generator set control shall indicate the existence of the warning and shutdown conditions on the control panel. Conditions required to be annunciated shall include:
1. Low oil pressure (warning).
 2. Low oil pressure (shutdown).
 3. Low coolant temperature (warning).
 4. High coolant temperature (warning).
 5. High coolant temperature (shutdown).
 6. High oil temperature (warning).
 7. Low coolant level (warning).
 8. Fail to crank (shutdown).
 9. Fail to start/overcrank (shutdown).
 10. Overspeed (shutdown).
 11. Low DC voltage (warning).
 12. High DC voltage (warning).
 13. Weak battery (warning).
 14. High AC voltage (shutdown).
 15. Low AC voltage (shutdown).
 16. Under frequency (shutdown).
 17. Overcurrent (warning).
 18. Overcurrent (shutdown).
 19. Emergency stop (shutdown).
- E. Engine Status Monitoring:
1. The following information shall be available from a digital status panel on the generator set control:
 - a. Engine oil pressure (psi or kPA).
 - b. Engine coolant temperature (degrees F or C).
 - c. Engine speed (rpm).
 - d. Number of hours of operation (hours).
 - e. Number of start attempts.
 - f. Battery voltage (DC volts).
 2. The control system shall also incorporate a data logging and display provision to allow logging of the last 10 warning or shutdown indications on the generator set, as well as total time of operation at various loads, as a percent of the standby rating of the generator set.

F. Engine Control Functions:

1. The control system provided shall include a cycle cranking system which allows for user selected crank time, rest time, and number of cycles. Initial settings shall be for three cranking periods of 15 seconds each, with 15-second rest period between cranking periods and a 75-second overcrank lockout per NFPA 110.
2. Manual Run/Stop Control Switch: When the mode control switch is in the MANUAL position and the MANUAL RUN/STOP switch is pressed, the Generator set shall start, bypassing time delay start. If the generator set is running in the MANUAL mode, pressing the RUN/STOP switch shall cause the generator set to shut down after a cool-down at idle period.
3. The control system shall include an engine governor control which functions to provide steady state frequency regulation, as noted elsewhere in this specification. The governor control shall include adjustments for gain, damping, and a ramping function to control engine speed and limit exhaust smoke while the unit is starting.
4. The control system shall include sensor failure monitoring logic for speed sensing, oil pressure, and engine temperature that is capable of discriminating between failed sensor or wiring components and an actual failure condition.

G. Alternator Control Functions:

1. The generator set shall include a full wave rectified automatic digital voltage regulation system that is matched and prototype tested by the engine manufacturer with the governing system provided. It shall be immune from misoperation due to load-induced voltage waveform distortion and provide a pulse width modulated output to the alternator exciter. The voltage regulation system shall be equipped with three-phase RMS sensing and shall control buildup of AC generator voltage to provide a linear rise and limit overshoot. The system shall include a torque-matching characteristic, which shall reduce output voltage in proportion to frequency below an adjustable frequency threshold. Torque matching characteristic shall be adjustable for roll-off frequency and rate and be capable of being curve-matched to the engine torque curve with adjustments in the field. The voltage regulator shall include adjustments for gain, damping, and frequency roll-off. Adjustments shall be broad range, and made via digital raise-lower switches, with an alphanumeric LED readout to indicate setting level. Rotary potentiometers for system adjustments are not acceptable.
2. A microprocessor-based protection device shall be provided to individually monitor all phases of the output current of the generator set and initiate an alarm (overcurrent warning) when load current exceeds 110% (adjustable) of the rated current of the generator set on any phase for more than 60 seconds (adjustable). The device shall shut down and lockout the generator set when output current level approaches the thermal damage point of the alternator (overcurrent shutdown). The protective functions provided shall be in compliance with the requirements of NFPA70 article 445.
3. A microprocessor-based protection device shall be provided to monitor all phases of the output current for short-circuit conditions. The control/protection system shall monitor the current level and voltage. The controls shall shut down and lockout the generator set when output current level approaches the thermal damage point of the alternator (short-circuit shutdown). The protective functions provided shall be in compliance with the requirements of NFPA70 article 445.
4. Controls shall be provided to monitor the kW load on the generator set and initiate an alarm condition (overload) when total load on the generator set exceeds the generator set rating for longer than 5 seconds (adjustable). Controls shall include a load shed control to operate a set of dry contacts (for use in shedding customer load devices) when the generator set is overloaded.

5. A microprocessor-based AC over and undervoltage monitoring system that responds only to true RMS voltage conditions shall be provided. The system shall initiate shutdown of the generator set when alternator output voltage exceeds 110% (adjustable) of the operator-set voltage level for more than 10 seconds (adjustable), or with no intentional delay when voltage exceeds 130% (adjustable). Undervoltage shutdown shall occur when the output voltage of the alternator is less than 85% (adjustable) for more than 10 seconds (adjustable). The system shall monitor individual phases and be connected line to neutral on three-phase 4-wire generator sets and for systems that are solidly grounded.
- H. A common fail contact for remote indication at the SCADA system shall be provided. Two auxiliary generator running contacts shall also be provided for remote indication at the SCADA System and to open the intake and exhaust dampers. All contacts shall be rated for 5 amps at 120 VAC.
- I. Generator control panel shall be mounted a maximum of 5 feet 6 inches above the equipment pad. CONTRACTOR shall be responsible for all required coordination.

2.09 WEATHER-PROTECTIVE GENERATOR ENCLOSURE

- A. Generator set weather-protective housing shall be provided factory-assembled to generator set base and radiator cowling. Housing shall provide ample airflow for generator set operation at rated load in the ambient conditions previously specified. All sheet metal shall be primed for corrosion protection and finish painted with the manufacturer's standard color using a two-step electrocoating paint process, or equal, meeting the performance requirements specified below. All surfaces of all metal parts shall be primed and painted. The painting process shall result in a coating that meets the following requirements:
 1. Primer thickness 0.5 to 2.0 mils. Top coat thickness 0.8 to 1.2 mils.
 2. Gloss according to ASTM D523, 80% \pm 5%. Gloss retention after 1 year shall exceed 50%.
 3. Crosshatch adhesion according to ASTM D3359, 4B-5B.
 4. Impact resistance according to ASTM D2794, 120-inch pounds to 160-inch pounds.
 5. Salt spray according to ASTM B117, 1000+ hours.
 6. Humidity according to ASTM D2247, 1000+ hours.
 7. Water soak according to ASTM D2247, 1000+ hours.
- B. Painting of hoses, clamps, wiring harnesses, and other nonmetallic service parts shall not be acceptable. Fasteners used shall be corrosion-resistant and designed to minimize marring of the painted surface when removed for normal installation of service work.
- C. The enclosure shall include hinged doors for access to both sides of the engine and alternator and the control equipment. Key locking and padlockable door latches shall be provided for all doors. All hardware and door hinges shall be stainless steel. All doors shall be provided with door stops to hold them in the open position.
- D. The enclosure shall include flexible coolant and lubricating oil drain lines that extend to the exterior of the enclosure, with internal drain valves and external radiator fill provision.
- E. The enclosure shall be provided with an exhaust silencer which is mounted inside of the enclosure. Silencer exhaust shall include a raincap and rainshield.

- F. The generator set shall be provided with a sound-attenuated housing which allows the generator set to operate at full rated load in an ambient temperature of up to 100°F. The enclosure shall reduce the sound level of the generator set while operating at full-rated load to a maximum of 76 dBA at any location, 7 meters from the generator set in a free-field environment.
- G. The enclosure shall be insulated with nonhygroscopic materials.

2.10 GENERATOR EMERGENCY SHUTDOWN PUSHBUTTON

- A. Furnish a red mushroom head, maintained-type pushbutton at the unit for manual initiation of a generator emergency shutdown. When the emergency stop pushbutton is pressed, the generator shall shut down and remain shut down until the emergency stop pushbutton is manually reset and the generator is called to run.
- B. The emergency shutdown pushbutton shall be provided with two sets of N.O. and N.C. contacts to monitor the signal at the generator.

PART 3-EXECUTION

3.01 INSTALLATION

- A. The standby power system shall be installed in accordance with the manufacturer's recommendations and all applicable codes.
- B. Installation of equipment shall include providing all interconnecting wiring between all major equipment provided for the on-site power system. CONTRACTOR shall also perform interconnecting wiring between equipment sections (when required), under the supervision of the equipment supplier.
- C. Equipment shall be installed on concrete housekeeping pads. Equipment shall be permanently fastened to the pad in accordance with manufacturer's instructions and seismic requirements of the site. All connections (e.g., fuel, water, electrical) to generator shall be made with flexible material/fitting to accommodate unit vibration.
- D. Equipment shall be initially started and operated by representatives of the manufacturer.
- E. All equipment shall be physically inspected for damage. Scratches and other installation damage shall be repaired prior to final system testing. Equipment shall be thoroughly cleaned to remove all dirt and construction debris prior to initial operation and final testing of the system.
- F. Generator fuel storage tank and system shall be installed by a certified installer in accordance with the 2021 International Building Code and the Office of Illinois State Fire Marshal requirements.

3.02 FIELD START-UP AND COMMISSIONING

- A. Provide the services of a qualified factory-trained manufacturer's representative to assist CONTRACTOR in installation and start-up of the equipment specified in this section. The manufacturer's representative shall provide technical direction and assistance to

CONTRACTOR in general operation of the equipment, connections and adjustments, and testing of the assembly and components contained therein.

- B. The manufacturer's representative shall provide inspection of the final installation. The manufacturer's representative shall perform site start-up and functional testing of the system. Upon completion of the manufacturer's start-up and testing, the manufacturer shall generate a Certificate of Proper Installation site start-up and test report, as specified in Section 01 91 00–Starting of Systems, documenting all systems checked, as well as any incomplete work remaining and operational deficiencies.
- C. CONTRACTOR shall provide a training session for up to three OWNER's representatives for one normal work day (not including start-up) at a job-site location determined by OWNER. The training session shall be conducted by a manufacturer's qualified representative. The training program shall consist of instruction on operation and testing of the assembly and major components within the assembly.
- D. CONTRACTOR shall provide three copies of the manufacturer's site start-up and test report to ENGINEER for review. Once ENGINEER has reviewed the report and all equipment is operating in accordance with the specifications, ENGINEER will make one site visit to check operation of the system. If the system is not ready or does not operate as specified, OWNER shall deduct payment to CONTRACTOR and make payment to ENGINEER for additional travel, expenses, and site visits until the equipment operates as specified. CONTRACTOR shall be responsible for all fuel, and electrical costs required to check operation of the system.

3.03 TESTING

- A. In addition to the standard factory tests, there shall be a 4-hour continuous load bank test at the jobsite before connection to load transfer switch, with loads from 10% to 100% of rated capacity to check voltage, frequency, fuel, air cooling, and ventilating systems so that they can be determined adequate for the application. This test shall be accomplished with a portable three-phase resistive load bank. All emergency warning and detection equipment shall be demonstrated to be operable by simulating failures. A signed test report shall be submitted to OWNER and ENGINEER with deficiencies noted, if any. After this test, the generator shall be connected to the plant and the operation and maintenance of the unit comprehensively demonstrated to OWNER. Correct phasing between the engine-generator and station shall be checked so that it will handle load. A minimum of two power failures shall be simulated.
- B. In addition to the load bank test above, after the unit is connected to the system, three simulated outages and a 4-hour run period on the actual facility shall also be provided.
- C. CONTRACTOR shall be responsible for all fuel costs for these tests.

END OF SECTION

SECTION 26 32 13.2

STANDBY POWER SYSTEM–PORTABLE

PART 1–GENERAL

1.01 SUMMARY

- A. Work Included: Steel base assembly, diesel engine, generator, engine-generator set controls, environmental systems and trailer.
- B. Related Sections and Divisions: Applicable provisions of Division 01 shall govern work in this section.

1.02 SUBMITTALS

- A. Submit shop drawings and product data in accordance with provisions of Section 01 33 00–Submittals.
- B. Shop drawings shall include the following:
 - 1. Detailed descriptions of equipment to be furnished, including all deviations from these specifications.
 - 2. Detailed layouts of all equipment and ancillary items.
 - 3. The manufacturer shall furnish schematic and wiring diagrams for the generator and an interconnection wiring diagram for the entire standby system. Test reports certified by the manufacturer shall be provided to ENGINEER for the entire system.

1.03 QUALITY ASSURANCE

- A. The generator shall be listed by Underwriters Laboratories, Inc., and be certified by the Canadian Standards Association.

1.04 OPERATING CONDITIONS

- A. Engine generator set shall be capable of continuous standby rating at 1,800 rpm, 0.8 PF, three-phase, 4-wire, 480 volts, at 60 hertz, and shall have a minimum capability of 100 kW, 125 kVA prime and 110 kW, 137 kVA standby. The unit shall be capable of 350 surge kW, 437 kVA for motor starting at a maximum sustained voltage dip of 10%.
- B. The generator set manufacturer shall verify the engine as capable of driving the generator with all accessories in place and operating, at the generator set kW rating after derating for the range of temperature expected in service and the altitude of the installation. Site conditions are 120°F maximum ambient and 685 feet altitude.
- C. Voltage regulation shall be $\pm 0.5\%$ of rated voltage for any constant load between no load and rated load.
- D. Frequency regulation shall be isochronous from steady state no load to steady state-rated load. Random frequency variation with any steady load from no load to full load shall not exceed $\pm 0.5\%$.

- E. Random Voltage Variation: The cyclic variations in RMS voltage shall not exceed $\pm 0.5\%$ of rated voltage for constant loads from no load to rated load, with constant ambient and operating temperature.
- F. Total Harmonic Distortion: The sum of AC voltage wave-form harmonics from no load to full linear load shall not exceed 5% of rated voltage (L-N, L-L, L-L-L), and no single harmonic shall exceed 3% of rated voltage.
- G. Telephone Influence Factor: TIF shall be less than 40 per NEMA MG1-22.43.
- H. The engine generator set shall accept a single-step load of 100% nameplate kW and power factor, less applicable derating factors, with the engine generator set at operating temperature.
- I. Motor starting capability shall be a minimum of 385 kVA. The generator set shall be capable of recovering to a minimum of 90% of rated no-load voltage following the application of the specified kVA load at near zero power factor applied to the generator set. Maximum voltage dip on application of this load, considering both alternator performance and engine speed changes, shall not exceed 25%.

1.05 WARRANTY

- A. Standard One-Year Warranty: Unless otherwise stated below, manufacturer shall warrant the equipment to be free from defects in material and workmanship for a period of one year from the earlier of either the date established for partial utilization in accordance with the Contract Documents or Substantial Completion of the project.

PART 2-PRODUCTS

2.01 ACCEPTABLE MANUFACTURERS

- A. The AC engine generator set shall be as manufactured by Caterpillar, Model XQ125, or equal.
- B. The Drawings and Specifications were prepared based on Caterpillar. CONTRACTOR shall include in the Bid and shall be responsible for the cost of any changes to accommodate other equipment including, but not limited to, structural, mechanical, and electrical work. CONTRACTOR shall also pay additional costs necessary for revisions of Drawings and/or Specifications by ENGINEER.

2.02 TRAILER AND WEATHER-PROTECTIVE GENERATOR ENCLOSURE

- A. Entire Standby Power System shall be mounted on manufacturer-provided, tandem-axle trailer, with the following minimum requirements:
 - 1. Weather-protective enclosure.
 - 2. 15-inch minimum wheels with radial construction trailer tires sized to exceed axle carrying capacity. Provide tongue-mounted spare tire.
 - 3. Weight-bearing fenders and running boards securely welded in place. Non-slip material shall be used on fenders and running boards required to access the generator set.

4. Tongue weight shall be 10% to 15% of total trailer weight, and is not to be considered when sizing tires and axles. A jack for hitch with wheel, pintle-eye hitch, and safety chains shall also be provided.
 5. Electric braking system on both axles with battery backup breakaway system.
 6. Clearance, parking and directional lights with reflectors, and lighted license plate holder and accessories. Plug for trailer lights shall match OWNER's existing receptacle.
 7. Trailer shall include DEF and fuel tanks sized to operate genset for a minimum of 24 hours. The tanks shall be mounted to the trailer. Fuel tank shall include a fuel gauge, lockable fill cap, and shall include 110% secondary containment. The DEF tank shall include a DEF quality sensor. Trailer shall be DOT rated.
 8. Electrical cable and plug holder.
 9. Rear stabilizer jacks.
- B. Where the top of the generator control panel is 6 feet or more aboveground, trailer shall include fold-up step(s) attached to the trailer.
- C. Generator set weather-protective housing shall be provided factory-assembled to generator set base and radiator cowling. Housing shall provide ample airflow for generator set operation at rated load in the ambient conditions previously specified. All sheet metal shall be primed for corrosion protection and finish painted with the manufacturer's standard color using a two-step electrocoating paint process, or equal, meeting the performance requirements specified below. All surfaces of all metal parts shall be primed and painted. The painting process shall result in a coating which meets the following requirements:
1. Primer thickness 0.5 mils. Top coat thickness 0.8 mils to 1.2 mils.
 2. Gloss per ASTM D523-89, 80% ±5%. Gloss retention after 1 year shall exceed 50%.
 3. Crosshatch adhesion per ASTM D3359-93, 4B-5B.
 4. Impact resistance per ASTM D2794-93, 120-inch pounds to 160-inch pounds.
 5. Salt Spray per ASTM B117-90, 1000+ hours.
 6. Humidity per ASTM D2247-92, 1000+ hours.
 7. Water Soak per ASTM D2247-92, 1000+ hours.
- D. Painting of hoses, clamps, wiring harnesses, and other nonmetallic service parts shall not be acceptable. Fasteners used shall be corrosion-resistant, and designed to minimize marring of the painted surface when removed for normal installation of service work.
- E. The enclosure shall include hinged doors for access to both sides of the engine and alternator and the control equipment. Key-locking and padlockable door latches shall be provided for all doors. All hardware and door hinges shall be stainless steel. All doors shall be provided with door stops to hold them in the open position.
- F. The enclosure shall include flexible coolant and lubricating oil drain lines that extend to the exterior of the enclosure, with internal drain valves and external radiator fill provision.
- G. The enclosure shall be provided with an exhaust silencer which is mounted inside of the enclosure. Silencer exhaust shall include a rain cap and rain shield.
- H. The generator set shall be provided with a sound-attenuated housing which allows the generator set to operate at full-rated load in an ambient temperature of up to 100°F. The enclosure shall reduce the sound level of the generator set while operating at full-rated load to a maximum of 66 dBA at any location 7 meters from the generator set in a free-field environment.

- I. The enclosure shall be insulated with nonhygroscopic materials.
- J. 125% environmental containment basin for oil and coolant.

2.03 ENGINE

- A. The engine shall be stationary, liquid-cooled, diesel for use with No. 2 diesel fuel. The design shall be 4-cycle, 4-cylinder, minimum displacement of 268 cubic inches, turbocharged, and aftercooled as required by engine manufacturer. Engine shall be certified as capable of driving the generator of the rating indicated above on a continuous standby basis for the duration of normal source interruptions.
- B. Engine accessories shall include the following:
 - 1. A 12-volt DC electric starter, as required by the engine manufacturer.
 - 2. Replaceable dry element air cleaner with restriction indicator.
 - 3. Positive displacement, mechanical, full-pressure lubrication oil pump, full-flow lubrication oil filters with replaceable elements, pressure relief valve, dipstick oil level indicator, and oil drain valve with hose extension. Provide all lubricants for proper operation of the unit.
 - 4. An electronic governor system shall provide automatic isochronous frequency regulation. The governing system dynamic capabilities shall be controlled as a function of engine coolant temperature to provide fast, stable operation at varying engine operating temperature conditions. The control system shall actively control the fuel rate and excitation as appropriate to the state of the generator set. Fuel rate shall be regulated as a function of starting, accelerating to start disconnect speed, accelerating to rated speed. The governing system shall include a programmable warm-up at idle, and cooldown at idle function. While operating in idle state, the control system shall disable the alternator excitation system.
 - 5. Engine protective devices to indicate alarm and engine shutdown for the following:
 - a. Low coolant temperature alarm.
 - b. Low coolant level alarm.
 - c. Low lubrication oil pressure alarm and shutdown.
 - d. High coolant temperature alarm and shutdown.
 - e. Overspeed shutdown.
 - f. Over-crank shutdown.
 - 6. Battery charging alternator 100 amp minimum, with solid-state voltage regulator.
 - 7. Engine shall be radiator-cooled by engine-mounted radiator system, including belt-driven pusher fan, coolant pump, and thermostat temperature control. Rotating parts shall be guarded against accidental contact. The cooling system shall be rated for full-rated load operation in a 104°F ambient condition. Provide radiator drain extension to the side of the generator. Extension shall include shutoff valve.
 - 8. The equipment supplier shall provide 50% ethylene glycol antifreeze solution to fill engine cooling system.
 - 9. Engine-mounted thermostatically controlled coolant heater to aid in quick starting. The coolant heater(s) shall be sized as recommended by the engine manufacturer to warm the engine to a minimum of 120°F in a 50°F ambient, in compliance with NFPA 110 requirements. Heater shall be rated single-phase, 120 volts, 1,000 watts and be disconnected whenever the engine starts. Heater shall be UL 499 listed and labeled. The coolant heater(s) shall include cord and plug with provisions to isolate the heater for replacement of the heater element without draining the coolant from the generator set.

10. Vibration isolators, spring/pad type, quantity as recommended by the generator set manufacturer.
11. An engine-driven, mechanical, positive displacement fuel pump and fuel filter with replaceable spin-on canister element.
12. Flexible supply and return fuel lines.
13. Fuel filter with replaceable element.
14. The engine shall be provided with all fuel system piping required for automatic operation of the system. All piping shall be black iron and be sized to provide proper fuel flow for the engine. The unit shall be provided with all supply, return, vent, and fill lines as required. Provide a check valve in the fuel supply line to prevent drain back of diesel fuel. Provide connections for connecting fuel system to the engine in compliance with applicable codes and regulations. All fuel piping shall be pressure tested for a minimum of 2 hours.

2.04 ENGINE EXHAUST SYSTEM

- A. Exhaust muffler shall be provided for the engine of size as recommended by manufacturer. Muffler shall be of the critical-grade type. Muffler shall be side inlet.
- B. Stainless steel flexible exhaust connections shall be provided as required for connection between engine exhaust manifold and exhaust line in compliance with applicable codes and regulations.
- C. Provide an exhaust condensation trap with manual drain valve to trap and drain off exhaust condensation and to prevent condensation from entering the engine.
- D. Provide a suitable rain cap at the stack outlet. Provide all necessary flanges and special fittings for proper installation.
- E. Engine emissions shall meet current Environmental Protection Agency (EPA) NSPS gas engine emission regulations. Engines shall be EPA Tier 4 final nonroad certified and emission approval documentation shall be provided to OWNER prior to final completion. All costs associated with any on-site EPA required emissions testing shall be included in the Bid.

2.05 STARTING AND CONTROL BATTERIES

- A. A UL-listed/CSA-certified 10-ampere voltage regulated battery charger shall be provided for the engine-generator set.
- B. Charger shall be UL 1236-BBHH listed and CSA or CUL certified for use in emergency applications.
- C. The charger shall be compliant with UL991 requirements for vibration resistance.
- D. The DC output voltage regulation shall be within $\pm 1\%$. The DC output ripple current shall not exceed 1 amp at rated output current level.
- E. The charger shall include the following features:
 1. LED indicating lamps to indicate normal charging (green) and fault condition (red).
 2. AC input overcurrent, overvoltage, and undervoltage protection.

3. DC output overcurrent protection.
 4. Corrosive-resistant aluminum enclosure.
- F. A calcium/lead antimony storage battery set of the heavy-duty starting type shall be provided. Battery voltage shall be compatible with starting system. The battery set shall be rated no less than 850 CCA, and shall be capable of a minimum of three 15-second cranking cycles. A battery rack constructed in conformance with NEC requirements and necessary cables and clamps shall be provided.

2.06 GENERATOR

- A. The generator shall be a single prelubricated bearing, self-aligning, 4-pole, two-thirds pitch, brushless, synchronous type, revolving field with amortisseur windings, and with direct-driven centrifugal blower fan for proper cooling and minimum noise. No brushes will be allowed. Generator shall be directly connected to engine flywheel housing, and driven through a flexible coupling to provide permanent alignment. Generator design shall prevent potentially damaging shaft currents.
- B. Insulation shall meet NEMA standards for Class H and shall be UL 1446 listed. The maximum temperature rise shall not exceed 150°C at 40°C ambient.
- C. The generator shall be three-phase, broad-range, reconnectable, and shall have 12 leads brought out to allow connection by user to obtain any of the available voltages for the unit.
- D. The generator set shall be capable of delivering rated output (kVA) at rated frequency and power factor, at any voltage not more than 5% above or below rated voltage.
- E. A permanent magnet generator (PMG) shall be included to provide a reliable source of excitation power for optimum motor starting and short-circuit performance. The PMG and controls shall be capable of sustaining and regulating current supplied to a single-phase or three-phase fault, at approximately 300% of rated current for not more than 10 seconds.
- F. The subtransient reactance of the alternator shall not exceed 15%, based on the standby rating of the generator set.
- G. Provide a 200-amp mainline circuit breaker with engine generator set for 480-volt, three-phase power. Circuit breakers shall meet the requirements specified in Section 26 28 00—Overcurrent Protective Devices.

2.07 ENGINE-GENERATOR SET CONTROL

- A. The generator set shall be provided with a microprocessor-based control system that is designed to provide automatic starting, monitoring, and control functions for the generator set. The control system shall also be designed to allow local monitoring and control of the generator set, and remote monitoring and control as described in this specification.
- B. The generator set mounted controls shall include the following features and functions.
Control Switches:
 1. Mode Select Switch. The mode select switch shall initiate the following control modes. When in the RUN or MANUAL position, the generator set shall start and accelerate to rated speed and voltage. In the OFF position, the generator set shall immediately stop,

- bypassing all time delays. In the AUTO position, the generator set shall be ready to accept a signal from a remote device to start and accelerate to rated speed and voltage.
2. EMERGENCY STOP switch. Switch shall be Red "mushroom-head," pushbutton. Depressing the emergency stop switch shall cause the generator set to immediately shut down, and be locked out from automatic restarting.
 3. RESET switch. The RESET switch shall be used to clear a fault and allow restarting the generator set after it has shut down for any fault condition.
- C. Generator Set AC Output Metering. The generator set shall be provided with a metering set, including the following features and functions: Digital metering set, 1% accuracy, to indicate generator RMS voltage and current (all three phases), frequency, output current, output kW, kW hours, and power factor. Generator output voltage shall be available in line-to-line and line-to-neutral voltages, and shall display all three-phase voltages (line-to-neutral or line-to-line), and total control on hours, as well as total values since reset.
- D. Generator Set Alarm and Status Display: The generator set control shall indicate the existence of the warning and shutdown conditions on the control panel. All conditions indicated below for warning shall be field-configurable for shutdown. Conditions required to be annunciated shall include:
1. Low oil pressure (warning).
 2. Low oil pressure (shutdown).
 3. Low coolant temperature (warning).
 4. High coolant temperature (warning).
 5. High coolant temperature (shutdown).
 6. High oil temperature (warning).
 7. Low coolant level (warning).
 8. Fail to crank (shutdown).
 9. Fail to start/overcrank (shutdown).
 10. Overspeed (shutdown).
 11. Low DC voltage (warning).
 12. High DC voltage (warning).
 13. Weak battery (warning).
 14. High AC voltage (shutdown).
 15. Low AC voltage (shutdown).
 16. Under frequency (shutdown).
 17. Overcurrent (warning).
 18. Overcurrent (shutdown).
 19. Overload (warning).
 20. Emergency stop (shutdown).
- E. Engine Status Monitoring:
1. The following information shall be available from a digital status panel on the generator set control:
 - a. Engine oil pressure (psi or kPA).
 - b. Engine coolant temperature (degrees F or C).
 - c. Engine speed (rpm).
 - d. Number of hours of operation (hours).
 - e. Number of start attempts.
 - f. Battery voltage (DC volts).
 2. The control system shall also incorporate a data logging and display provision to allow logging of the last 10 warning or shutdown indications on the generator set, as well as

total time of operation at various loads, as a percent of the standby rating of the generator set.

F. Engine Control Functions:

1. The control system provided shall include a cycle-cranking system which allows for user-selected crank time, rest time, and number of cycles. Initial settings shall be for three cranking periods of 15 seconds each, with 15-second rest period between cranking periods.
2. The control system shall include an idle mode control which allows the engine to run in idle mode in the RUN position only. In this mode, the alternator excitation system shall be disabled.
3. The control system shall include an engine governor control which functions to provide steady state frequency regulation, as noted elsewhere in this specification. The governor control shall include adjustments for gain, damping, and a ramping function to control engine speed and limit exhaust smoke while the unit is starting.
4. The control system shall include time-delay start (adjustable 0 seconds to 300 seconds) and time-delay stop (adjustable 0 seconds to 600 seconds) functions.
5. The control system shall include sensor failure monitoring logic for speed sensing, oil pressure, and engine temperature which is capable of discriminating between failed sensor or wiring components, and an actual failure condition.

G. Alternator Control Functions:

1. The generator set shall include a full-wave rectified automatic digital voltage regulation system that is matched and prototype-tested by the engine manufacturer, with the governing system provided. It shall be immune from misoperation due to load-induced voltage waveform distortion, and provide a pulse width modulated output to the alternator exciter. The voltage regulation system shall be equipped with three-phase RMS sensing, and shall control buildup of AC generator voltage to provide a linear rise and limit overshoot. The system shall include a torque-matching characteristic which shall reduce output voltage in proportion to frequency below an adjustable frequency threshold. Torque-matching characteristic shall be adjustable for roll-off frequency and rate, and be capable of being curve-matched to the engine torque curve with adjustments in the field. The voltage regulator shall include adjustments for gain, damping, and frequency roll-off. Adjustments shall be broad range, and made via digital raise-lower switches, with an alphanumeric LED readout to indicate setting level. Rotary potentiometers for system adjustments are not acceptable.
2. A microprocessor-based protection device shall be provided to individually monitor all phases of the output current of the generator set and initiate an alarm (overcurrent warning) when load current exceeds 110% of the rated current of the generator set on any phase for more than 60 seconds. The device shall shut down and lock out the generator set when output current level approaches the thermal damage point of the alternator (overcurrent shutdown). The protective functions provided shall be in compliance to the requirements of NFPA70 article 445.
3. A microprocessor-based protection device shall be provided to monitor all phases of the output current for short-circuit conditions. The control/protection system shall monitor the current level and voltage. The controls shall shut down and lock out the generator set when output current level approaches the thermal damage point of the alternator (short-circuit shutdown). The protective functions provided shall be in compliance to the requirements of NFPA70 Article 445.
4. A microprocessor-based AC over-under-voltage monitoring system that responds only to true RMS voltage conditions shall be provided. The system shall initiate shutdown of

the generator set when alternator output voltage exceeds 110% of the operator-set voltage level for more than 10 seconds, or with no intentional delay when voltage exceeds 130%. Undervoltage shutdown shall occur when the output voltage of the alternator is less than 85% for more than 10 seconds. The system shall monitor individual phases and be connected line-to-neutral on three-phase, 4-wire generator sets, and for systems that are solidly-grounded.

5. The generator set control shall include a 120 VAC control heater. Heater shall include cord and plug.

- H. A common fail contact for external connection to an audible alarm and remote alarm shall be provided. One auxiliary generator running contact shall also be provided for remote indication. All contacts shall be rated for 5 amps at 120 VAC.

2.08 MISCELLANEOUS EQUIPMENT

- A. Provide duplex 120-volt and simplex single-phase, 20-amp receptacles for plugin of miscellaneous equipment.
- B. Shore power connection point with 30 A, NEMA locking input receptacle, 120-volt grounded plugs for battery charger and block heater. Provide 20-foot outdoor power cord with appropriate twist lock male ends for shore power connection from building.
- C. On the load side of the 100-amp, 3-pole main line circuit breaker, provide a 50-foot, 3-wire, No. 3 type G/GGC cable assembly.
- D. Provide adequately-sized hangers or storage space on the generator set for storage of the two cable assemblies specified above, as well as a holder for each plug.

2.09 TOOLS AND SPARE PARTS

- A. The required spare parts for the generator shall be those as recommended by the manufacturer and shall include the following items as a minimum:
 1. All special tools required for normal operation and maintenance.
 2. One air cleaner element.
 3. One oil filter.
 4. One set of fan belts.
- B. All spare parts shall be packed in containers that are clearly identifiable with indelible markings on containers.

2.10 SCHEDULED OIL SAMPLING

- A. In order to minimize engine downtime, the supplier of the standby generator must provide an oil-sampling analysis kit that operating personnel shall use for scheduled oil sampling.
- B. Scheduled oil sampling shall be of the atomic absorption spectrophotometry method, and shall be accurate within a fraction of one part per million for the following elements: iron, chromium, copper, aluminum, silicon, and lead. In addition, the sample shall be tested for the presence of water, fuel dilution, and antifreeze.

- C. All equipment needed to take oil samples shall be provided in a kit at the time of acceptance, and shall include the following:
 - 1. Sample Extraction Gun: One.
 - 2. Bottles: Ten.
 - 3. Postage-Paid Mailers: Ten.
 - 4. Written Instructions: One.
- D. Immediate notification shall be provided to OWNER when analysis shows any critical reading. If readings are normal, a report showing that the equipment is operating within established parameters shall be provided.
- E. The scheduled oil-sampling kit shall be made available at additional cost to OWNER beyond the mandatory starter kit specified previously and shall be optional for OWNER to continue this service after the starter kit has been depleted.

PART 3-EXECUTION

3.01 INSTALLATION

- A. The standby power system shall be built in accordance with the manufacturer's recommendations and all applicable codes.
- B. Equipment shall be initially started and operated by representatives of the manufacturer.
- C. All equipment shall be physically inspected for damage. Scratches and other installation damage shall be repaired prior to final system testing. Equipment shall be thoroughly cleaned to remove all dirt and construction debris prior to initial operation and final testing of the system.

3.02 START-UP, TESTING, AND TRAINING

- A. CONTRACTOR shall include 8 hours of start-up and testing by a certified, factory-trained engineer. Prior to making electrical connections, CONTRACTOR shall have a factory-trained service technician meet at the jobsite to go over the installation, to preclude any installation and start-up problems. Start-up services shall include, but not be limited to, inspection of CONTRACTOR installation and functional testing of the standby power system. On-site time shall be over and above the cost of travel and travel time to the site.
- B. CONTRACTOR shall provide a training session for up to three OWNER's representatives for one normal workday (not including start-up), at a jobsite location determined by OWNER. The training session shall be conducted by a manufacturer's qualified representative. The training program shall consist of instruction on operation and testing of the assembly, circuit breakers, and major components within the assembly.

3.03 TESTING

- A. In addition to the standard factory tests, there shall be a 4-hour continuous load bank test at the jobsite before connection to load transfer switch, with loads from 10% to 100% of rated capacity to check voltage, frequency, fuel, air cooling and ventilating systems so that they can be determined adequate for the application. This test shall be accomplished with a

portable three-phase resistive load bank. All emergency warning and detection equipment shall be demonstrated to be operable by simulating failures. A signed test report shall be submitted to OWNER and ENGINEER with deficiencies noted, if any. After this test, the electrical plant shall be connected to the plant, and the operation and maintenance of the unit comprehensively demonstrated to OWNER. Correct phasing between the engine generator and station shall be verified so that it will handle load. A minimum of two power failures shall be simulated.

- B. In addition to the load bank test above, after the unit is connected to the system, three simulated outages and a 2-hour run period on the actual facility shall also be provided (208-volt and 480-volt).
- C. CONTRACTOR shall be responsible for all fuel costs for these tests.

END OF SECTION

SECTION 26 36 14

GENERATOR DOCKING STATIONS

PART 1—GENERAL

1.01 SUMMARY

- A. Work Included:
 - 1. Provide generator docking stations where shown on the Drawings.
 - 2. The system shall be a completely integrated assembly for manual connection of a portable generator to the electrical distribution system including all connectors as specified herein.
- B. Related Sections and Divisions: Applicable provisions of Division 01 shall govern work in this section.

1.02 QUALITY ASSURANCE

- A. The generator docking station shall be listed by Underwriters Laboratories, Inc.

1.03 SUBMITTALS

- A. Submit shop drawings and product data in accordance with provisions of Section 01 33 00—Submittals.
- B. Shop drawings shall include the following:
 - 1. Detailed descriptions of equipment to be furnished, including all deviations from these specifications.
 - 2. Detailed layouts of all cubicles and equipment.
 - 3. The manufacturer shall furnish schematic and wiring diagrams for the generator docking station and an interconnection wiring diagram for the entire system.

1.04 DELIVERY, STORAGE, AND HANDLING

- A. Store in a clean, dry space. Maintain factory wrapping or provide an additional heavy canvas or heavy plastic cover to protect units from dirt, water, construction debris, and traffic.
- B. Handle in accordance with manufacturer's written instructions. Lift only with lugs provided for the purpose. Handle carefully to avoid damage to components, enclosure, and finish.

1.05 WARRANTY

- A. Standard One-Year Warranty: Unless otherwise stated below, manufacturer shall warrant the equipment to be free from defects in material and workmanship for a period of one year from the earlier of either the date established for partial utilization in accordance with the Contract Documents or Substantial Completion of the project.

PART 2-PRODUCTS

2.01 ACCEPTABLE MANUFACTURERS

- A. The generator docking station shall be as manufactured by Trystar GDS Series, Asco Series 300, or equal.
- B. The Drawings and Specifications were prepared based on Trystar. CONTRACTOR shall include in the Bid and shall be responsible for the cost of any changes to accommodate other equipment. CONTRACTOR shall also pay additional costs necessary for revisions of Drawings and/or Specifications by ENGINEER.

2.02 GENERATOR DOCKING STATIONS

- A. Provide complete generator docking stations as shown on the Drawings. Generator docking stations shall be UL 1008 and UL 50 listed.
- B. Enclosure:
 - 1. NEMA 3R aluminum with powder coat finish, suitable for wall mounting.
 - 2. The NEMA 3R enclosure rating shall be maintained while generator cabling is connected to the docking station.
 - 3. The front door shall be hinged, padlockable, and include a hinged access plate to prevent access to bottom of enclosure.
 - 4. Provide extra depth for bottom conduit access.
 - 5. Where shown on the Drawings, provide a kirk key interlock on the enclosure door. Coordinate with the manufacturer of other Division 26 sections as required to key-alike associated locks.
- C. All bussing shall be silver-plated copper. Neutral bussing shall be 100% rated.
- D. Wiring for permanently-connected wiring shall utilize mechanical lugs and be located behind a physical barrier. Provide lugs as required for permanent wiring as shown on the Drawings.
- E. Temporary cable connections shall utilize female cam connectors that are color-coded based on the system voltage. Cam connectors shall be Series 16 Cam-Lok connectors, or equal.
- F. Generator docking station ratings shall be as shown on the Drawings, with a factory-installed phase monitoring relay and short circuit withstand rating of 65 kAIC.
- G. Generator docking stations shall be provided with the following factory-installed equipment:
 - 1. Phase monitoring relay.
 - 2. 20-amp, 120-volt AC, GFCI receptacle.
 - 3. Surge protection device.

PART 3-EXECUTION

3.01 INSTALLATION

- A. The installation of this system shall comply with the directions and recommendations of authorized factory representatives. Provide authorized factory representative supervision necessary for proper installation.

END OF SECTION

SECTION 26 36 15

MANUAL TRANSFER GENERATOR DOCKING STATIONS

PART 1–GENERAL

1.01 SUMMARY

- A. Work Included:
 - 1. Provide manual transfer generator docking stations where shown on the Drawings.
 - 2. The system shall be a completely integrated assembly for manual connection of a portable generator to the electrical distribution system including all connectors as specified herein.
- B. Related Sections and Divisions: Applicable provisions of Division 01 shall govern work in this section.

1.02 QUALITY ASSURANCE

- A. The manual transfer generator docking station shall be listed by Underwriters Laboratories, Inc.

1.03 SUBMITTALS

- A. Submit shop drawings and product data in accordance with provisions of Section 01 33 00–Submittals.
- B. Shop drawings shall include the following:
 - 1. Detailed descriptions of equipment to be furnished, including all deviations from these specifications.
 - 2. Detailed layouts of all cubicles and equipment, including voltage rating, amperage, and short-circuit.
 - 3. The manufacturer shall furnish schematic and wiring diagrams for the manual transfer generator docking station and an interconnection wiring diagram for the entire system.

1.04 DELIVERY, STORAGE, AND HANDLING

- A. Handle in accordance with manufacturer's written instructions. Lift only with lugs provided for the purpose. Handle carefully to avoid damage to components, enclosure, and finish.

1.05 WARRANTY

- A. Standard One-Year Warranty: Unless otherwise stated below, manufacturer shall warrant the equipment to be free from defects in material and workmanship for a period of one year from the earlier of either the date established for partial utilization in accordance with the Contract Documents or Substantial Completion of the project.

PART 2–PRODUCTS

2.01 ACCEPTABLE MANUFACTURERS

- A. The generator docking station shall be as manufactured by Trystar MTS Series, Asco Series 300, or equal.
- B. The Drawings and Specifications were prepared based on Trystar. CONTRACTOR shall include in the Bid and shall be responsible for the cost of any changes to accommodate other equipment. CONTRACTOR shall also pay additional costs necessary for revisions of Drawings and/or Specifications by ENGINEER.

2.02 MANUAL TRANSFER GENERATOR DOCKING STATIONS

- A. Provide complete manual transfer generator docking stations as shown on the Drawings. Manual transfer generator docking stations shall be UL 1008 and UL 50 listed.
- B. Enclosure:
 - 1. NEMA 4X stainless with powder coat finish, suitable for wall mounting.
 - 2. The NEMA 4X enclosure rating shall be maintained while generator cabling is connected to the docking station.
 - 3. The front door shall be hinged, padlockable, and include a hinged access plate to provide access to bottom of enclosure.
 - 4. Provide extra depth for bottom conduit access.
- C. All bussing shall be silver-plated copper. Neutral bussing shall be 100% rated.
- D. Wiring for permanently-connected wiring shall utilize mechanical lugs and be located behind a physical barrier. Provide lugs as required for permanent wiring as shown on the Drawings.
- E. Temporary cable connections shall utilize female cam connectors that are color-coded based on the system voltage. Cam connectors shall be Series 16 Cam-Lok connectors, or equal.
- F. Manual transfer generator docking station ratings shall be as shown on the Drawings, with a factory-installed phase monitoring relay and short circuit withstand rating of 65 kAIC.
- G. Manual transfer generator docking stations shall be provided with the following factory-installed equipment:
 - 1. Phase monitoring relay.
 - 2. 20-amp, 120-volt AC, GFCI receptacle.
 - 3. Surge protection device.
 - 4. Two wire auto start.
 - 5. Anti-condensation strip heater and thermostat.
 - 6. Utility Available pilot light.
- H. Manual transfer generator docking stations shall have an integrated three-position transfer switch (Utility–Off–Generator) for break-before-make transfer between permanent and temporary sources.

PART 3-EXECUTION

3.01 INSTALLATION

- A. The installation of this system shall comply with the directions and recommendations of authorized factory representatives. Provide authorized factory representative supervision necessary for proper installation.
- B. Provide manual transfer generator docking stations where indicated on the Drawings. Maximum mounting height shall be 42 inches above grade unless approved by OWNER and ENGINEER.

END OF SECTION

SECTION 26 36 23

AUTOMATIC TRANSFER SWITCHES

PART 1–GENERAL

1.01 SUMMARY

- A. Work Included:
 - 1. Provide an automatic transfer switch control system where shown on the Drawings.
 - 2. The system shall be a completely integrated assembly for automatic, unattended operation and control of the standby power system. System operation shall be as described in the following sections.
- B. Related Sections and Divisions: Applicable provisions of Division 01 shall govern work in this section.

1.02 SUBMITTALS

- A. Submit shop drawings and product data in accordance with provisions of Section 01 33 00–Submittals.
- B. Shop drawings shall include the following:
 - 1. Detailed descriptions of equipment to be furnished, including all deviations from these specifications.
 - 2. Detailed layouts of all cubicles and equipment.
 - 3. The manufacturer shall furnish schematic and wiring diagrams for the automatic transfer switch and an interconnection wiring diagram for the entire standby system. Test reports certified by the manufacturer shall be provided to ENGINEER for the entire system.

1.03 QUALITY ASSURANCE

- A. The transfer switch shall be listed by Underwriters Laboratories, Inc. (Std. 1008) and be approved by the Canadian Standards Association.

1.04 WARRANTY

- A. Standard One-Year Warranty: Unless otherwise stated below, manufacturer shall warrant the equipment to be free from defects in material and workmanship for a period of one year from the earlier of either the date established for partial utilization in accordance with the Contract Documents or Substantial Completion of the project.

PART 2–PRODUCTS

2.01 ACCEPTABLE MANUFACTURERS

- A. The automatic transfer switch shall be as manufactured by ASCO 7000, Cummins Power Generation X-Series, Kohler KEP, 200-amp, 3-pole, or equal.

- B. The Drawings and Specifications were prepared based on ASCO. CONTRACTOR shall include in the Bid and shall be responsible for the cost of any changes to accommodate other equipment. CONTRACTOR shall also pay additional costs necessary for revisions of Drawings and/or Specifications by ENGINEER.

2.02 AUTOMATIC TRANSFER SWITCHES

- A. Provide complete automatic transfer switch as shown on the Drawings. Interlocked molded case circuit breakers or contactors are not acceptable.
- B. The transfer switch shall be capable of switching all classes of load and shall be rated for continuous duty when installed in a nonventilated enclosure constructed in accordance with Underwriters Laboratories, Inc., UL 1008. The transfer switch shall be provided with a NEMA 1 enclosure.

2.03 CONSTRUCTION AND PERFORMANCE

- A. The transfer switch shall be double-throw, actuated by a single electrical operator momentarily energized and connected to the transfer mechanism by a simple overcenter linkage, with a minimum transfer time of 400 milliseconds.
- B. The transfer switch shall have the ability to detect under and over-voltage, under and over-frequency, voltage imbalance, incorrect phase rotation, and phase loss.
- C. The time delay between the opening of the closed contacts and the closing of the open contacts shall allow for voltage decay before transfer.
- D. The transfer switch shall allow the motor and transformer loads to be reenergized after transfer with normal inrush current. The transfer switch shall be capable of transferring successfully in either direction with 70% of rated voltage applied to the switch terminals.
- E. The normal and emergency contacts shall be positively interlocked mechanically and electrically to prevent simultaneous closing. Main contacts shall be mechanically locked in position in both the normal and standby positions without the use of hooks, latches, magnets, or springs and shall be silver tungsten alloy. All contacts shall be 100% rated. Separate arcing contacts with magnetic blowouts shall be provided on all transfer switches.
- F. The transfer switch shall be equipped with a safe manual operator designed to prevent injury to operating personnel. The manual operator shall provide the same transfer speed as the electrical operator to prevent a flashover from switching the main contacts slowly.
- G. The transfer switch shall be equipped with a digital display that has the ability to monitor load power conditions, network status, review transfer switch events, and adjust transfer switch parameters. The display shall also include a bar graph display that indicates the level of power being supplied to the load as well as three-phase voltage, current, frequency, power factor, and kilowatts.

2.04 SEQUENCE OF OPERATION

- A. Engine starting contacts shall be provided to start the generating plant should the voltage of the normal source drop below 80% on any phase after an adjustable time delay to allow for

momentary dips. The transfer switch shall transfer to standby when 90% of rated voltage and frequency has been reached. After restoration of normal power on all phases to 90% of rated voltage, an adjustable time delay period of zero to 31 minutes shall delay retransfer to allow stabilization of normal power. If the standby power source should fail during this time delay period, the switch shall automatically return to the normal source. After retransfer to normal, the engine-generator shall be allowed to operate at no-load for a period of 5 minutes. Two auxiliary contacts rated 25 amps, 120 volts shall be mounted on the main shaft; one closed on normal, the other closed on standby. All relays, timers, control wiring, and accessories shall be front accessible. In addition, one set of relay contacts shall be provided to open upon loss of the normal power supply. All control wire terminations shall be identified by tubular sleeve-type markers.

- B. The automatic transfer switch shall include the following functions. Adjustable time delays and features described below shall be operator-adjustable from the front of the transfer switch and shall not require the use of a laptop, software, or external programming device.
1. Time delay to override momentary normal source power outages to delay engine start signal and transfer switch operation. Adjustable 0.5 to 90 seconds.
 2. Time delay relays to control contact transition time on transfer to either source, adjustable 1 to 300 seconds (Programmed Transition).
 3. Time delay on retransfer to normal. Adjustable 0 to 31 minutes, with engine overrun to provide fixed 5-minute unloaded engine operation after retransfer to normal.
 4. Test with load-Auto-Test without load selector switch to simulate normal power failure. (Maintained Type).*
 5. Contact to close on failure of normal source to initiate engine starting or other customer functions.
 6. Contact to open on failure of normal source to initiate engine starting or other customer functions.
 7. Green pilot light to indicate switch in normal position.*
 8. Red pilot light to indicate switch in standby position.*
 9. Auxiliary contact closed in normal position.
 10. Auxiliary contact closed in standby position.
 11. Adjustable relay to prevent transfer to standby until voltage and frequency of generating plant have reached acceptable limits.
 12. Plant exerciser with 7-day time clock, multiple test schedules, and programmable exceptions for holidays, weekends, etc.

* Front cabinet door mounted.

- C. When coordinated with circuit breakers, the automatic transfer switch shall have the following short-circuit withstand capability:

Withstand Capability (RMS Amps, Symmetrical) Testing at 480 VAC	
Switch Ampere Rating	ATS Coordinated with Molded Case Circuit Breakers
200	65,000

- D. During the withstand tests, there shall be no contact welding or damage. The tests shall be performed on identical samples without the use of current limiting fuses. Oscillograph traces across the main contact shall verify that contact separation has not occurred. These procedures shall be in accordance with UL 1008 and testing shall be certified by Underwriters Laboratories or any nationally recognized independent testing laboratory.

- E. When conducting temperature rise tests to UL 1008, the manufacturer shall include postendurance temperature rise tests to verify the ability of the transfer switch to carry full-rated current after completing the overload and endurance tests.
- F. As a precondition for approval, the manufacturer of the automatic transfer switch shall verify that the switches are listed by Underwriters Laboratories, Inc., UL 1008 with withstand and close-in values at least equal to the interrupting rating of the circuit breaker and/or fuse that is specified to protect the circuit.

PART 3–EXECUTION

3.01 INSTALLATION

- A. The installation of this system shall comply with the directions and recommendations of authorized factory representatives. These representatives shall offer the supervision necessary for proper installation.
- B. A final inspection and an initial start-up of the system shall be provided by the factory representatives.
- C. A Certificate of Proper Installation as specified in Section 01 91 00–Starting of Systems, shall be provided by the authorized factory representatives which states that the system is properly installed and does properly function as recommended by the factory and as described herein shall be submitted to ENGINEER.
- D. A test run shall be performed by the authorized factory representatives in the presence of CONTRACTOR and ENGINEER or their representatives; the time of this test run shall be mutually agreed upon by all persons concerned.

3.02 START-UP AND TRAINING

- A. CONTRACTOR shall include 8 hours of start-up by a certified, factory-trained engineer. Start-up services shall include, but not be limited to, inspection of CONTRACTOR installation and functional testing of the ATS assembly. On-site time shall be over and above the cost of travel and travel time to the site.
- B. CONTRACTOR shall provide a training session for up to three OWNER's representatives for one normal workday (not including start-up) at a job site location determined by OWNER. The training session shall be conducted by a manufacturer's qualified representative. The training program shall consist of instruction on operation and testing of the assembly, simulated outages, and review of major components within the assembly.

END OF SECTION

SECTION 31 23 00

EXCAVATION, FILL, BACKFILL, AND GRADING

PART 1—GENERAL

1.01 SUMMARY

- A. Work Included: Excavating, filling, backfilling, and grading for this work includes, but is not necessarily limited to:
 - 1. Excavating for Foundations.
 - 2. Furnishing and Placing all Fill and Backfill.
 - 3. Provide Compaction of all Fill and Backfill.
 - 4. Rough and Finish Grading Prior to Paving, Seeding, etc.
- B. Related Sections and Divisions: Applicable provisions of Division 01 shall govern work in this section.
- C. Payment: All common excavation shall be included in the Lump Sum Bid. Changes which require additions to or deductions from the excavation will be adjusted on the basis of the unit price for changes contained in the Contract.

1.02 REFERENCED STANDARDS

- A. Standard Specifications: Unless otherwise indicated, Standard Specifications within this section shall refer to the State of Illinois Department of Transportation, Standard Specifications for Road and Bridge Construction, current edition, including all issued supplemental specifications.
- B. ASTM C33—Standard Specification for Concrete Aggregates.
- C. ASTM D698—Standard Test Methods for Laboratory Compaction Characteristics of Soil Using Standard Effort (12,400 ft-lbf/ft³ (600 kN-m/m³)).
- D. ASTM D1557—Standard Test Methods for Laboratory Compaction Characteristics of Soil Using Modified Effort (56,000 ft-lbf/ft³ (2,700 kN-m/m³)).

1.03 SUBMITTALS

- A. Submit sources and gradations for materials proposed for use as compacted fill, utility trench backfill, trench bedding and cover material, crushed stone mat, and granular cushion.
- B. Submit samples of materials proposed for use in Paragraph 1.03.A to a soils testing laboratory for analysis of its suitability and for recommendations on moisture content during compaction, compaction methods, or other appropriate information.
- C. Submit sufficient samples of each different type or classification of soil to obtain representative values.

1.04 JOB CONDITIONS

- A. The elevations shown for existing work and ground are reasonably correct, but are not guaranteed to be absolutely accurate. No extras will be allowed because of variations between drawings and actual grades.
- B. No soil borings were made for this project. CONTRACTOR shall conduct its own investigation to determine physical conditions at the site which may affect the work.

PART 2—PRODUCTS

2.01 COMPACTED FILL

- A. All fill and backfill material designated to be compacted fill shall be granular with no stones larger than 4 inches and shall be reasonably well-graded throughout the particle size range. A minimum 65% of the material shall pass the 3/4-inch sieve, and the material shall be capable of being compaction tested in accordance with ASTM D698. Of that portion of the material passing the No. 4 sieve, not more than 25% shall pass the No. 200 sieve, and material shall have less than 5% clay content. When placing fill during wet weather or in wet areas, this requirement shall be modified to not more than 5% passing the No. 200 sieve. Adequately dewatered areas are not defined as wet areas.
- B. Native material may be used as compacted fill if it meets the above specification. CONTRACTOR shall determine whether native material meets the above specification. CONTRACTOR shall provide all needed fill material whether from on-site or off-site at no additional cost to OWNER.

PART 3—EXECUTION

3.01 GENERAL

- A. Prior to all excavating, CONTRACTOR shall become thoroughly familiar with the site and site conditions.

3.02 PROTECTION

- A. CONTRACTOR shall provide all necessary sheeting, shoring, or other soil retention systems including all labor, material, equipment, and tools required, or as necessary to maintain the excavation in a condition to provide safe working conditions, to permit the safe and efficient installation of all items of Contract work, and to protect adjacent property. CONTRACTOR shall be held liable for any damage which may result to property from excavation or construction operations. Sheeting, shoring, and other soil retainage systems shall be withdrawn or removed in a manner so as to prevent subsequent settlement of structures, utilities, and other improvements.
- B. Design of sheet piling and other soil retaining systems shall be the sole responsibility of CONTRACTOR. Where such systems are shown on the Drawings, no parameters such as embedment depth, section profile, presence or lack of walers, etc., nor system type or suitability shall be inferred. CONTRACTOR is responsible for designing and providing a fully functional system compatible with construction and site requirements.

- C. Nothing in this specification shall be deemed to allow the use of protective systems less effective than those required by the Occupational Safety and Health Administration (OSHA) and other applicable code requirements.

3.03 FINISH ELEVATIONS AND LINES

- A. CONTRACTOR is responsible for establishing finish elevations and lines.
- B. Where lasers are used, CONTRACTOR shall check the Work against intermediate grade stakes. Prior to initial use of the laser, CONTRACTOR shall set up laser on ground surface and check line and gradient controls. Lasers not functioning properly shall be immediately removed.
- C. If existing property stakes, not within the limits of the trench or street slope limits, are removed or damaged by CONTRACTOR, CONTRACTOR shall bear the cost of replacement. Replacement shall be made by a legal survey performed by a licensed Land Surveyor hired by OWNER. Cost for survey shall be deducted from the Contract Price.

3.04 COMMON EXCAVATION

- A. After the site has been cleared and stripped, the site shall be cut and filled to the indicated subgrade as shown or specified.
- B. All excavated material that does not meet the specification for compacted fill or meets the specification but is not required for backfill or fill shall be classified as excess material and shall be removed from the site and disposed of at CONTRACTOR's expense.
- C. All material other than suitable bearing soil or bedrock shall be removed from under concrete to be poured on ground.
- D. Excavation for all footings, foundation walls, pits, etc., shall be large enough to provide adequate clearance for the proper execution for the work within them.
- E. Excavation for subgrade and subgrade undercut shall be performed using a smooth-edged (toothless) backhoe bucket to minimize disturbance of subgrade soils. Toothed buckets may be used for bulk excavation but shall not be used when approaching final design subgrade elevations for foundation-bearing soils.
- F. When excavations reach subgrade elevations as shown on the Drawings or as specified herein, the ENGINEER will observe the bottom material. Where, in the opinion of the ENGINEER, unsuitable foundation material is found at the level of the subgrade, unsuitable foundation material shall be removed and replaced with material and placing methods as specified under compacted fill and backfill.
- G. Excavations that are undercut beneath the foundation shall extend beyond the perimeter of the foundation 1 foot plus a distance at least equal to the depth of undercut below footing grade.
- H. CONTRACTOR shall backfill and compact all overexcavated areas.

3.05 PREPARATION OF SUBGRADE

- A. After the site has been cleared, stripped, and excavated to subgrade, thoroughly compact subgrade to the requirements specified for compacted fill below. Scarify and moisture condition the subgrade.
- B. Remove all ruts, hummocks, and other uneven surfaces by surface grading prior to placement of fill.

3.06 COMPACTED FILL AND BACKFILL

- A. All fill and backfill, except as otherwise specified, shall be compacted fill placed to within 4 inches of the bottom of the topsoil or to the bottom of the structure or other improvement.
- B. In fill areas above existing grade around structures, compacted fill shall be placed within a minimum of 10 feet from the structure.
- C. No fill shall be placed under water or over unsuitable subgrade conditions.
- D. All fill and backfill, except embankment fill and clay fill, shall be compacted as follows:
 - 1. Class 1 Compaction: This class of compaction shall apply to all fill areas under buildings, structures, piping, bituminous roadway and parking areas, curb and gutter, and backfill within 10 feet of structure walls. All compacted material shall be placed in uniform layers not exceeding 8 inches in loose thickness prior to compaction. Each layer shall be uniformly compacted to a dry density at least 95% of the maximum dry density as determined by a laboratory compaction test at the optimum moisture content (ASTM Test Designation D698). Compaction shall be obtained by compaction equipment appropriate for the conditions.
 - 2. Class 2 Compaction: This class of compaction shall be used in excavated areas beyond 10 feet of structures without any piping or adjacent foundations. Material for backfill shall be granular material as specified above. The material shall be deposited, spread, and leveled in layers generally not exceeding 12 inches in thickness before compaction. Each layer of the fill shall be compacted to at least 90% of the maximum dry density (testing same as Class 1). Compaction shall be obtained by compaction equipment appropriate for the conditions.
- E. No frozen material shall be placed nor shall any material be placed on frozen ground.
- F. Four inches of clay fill shall be placed and compacted to at least a firm consistency in areas to be seeded or sodded prior to placement of topsoil.

3.07 GRADING

- A. CONTRACTOR shall perform all rough and finish grading required to attain the elevations shown on the Drawings.
- B. Grading Tolerances:
 - 1. Rough Grade: Buildings, parking areas, and sidewalks— ± 0.1 feet.
 - 2. Finish Grade: Granular cushion or crushed stone mat under concrete slabs— ± 0.03 feet.
 - 3. Lawn areas away from buildings, parking areas, and sidewalks— ± 0.25 feet.

3.08 MAINTENANCE OF SURFACE

- A. CONTRACTOR shall maintain all backfilling, resurfacing, repaving, and other surface improvements constructed under this Contract. CONTRACTOR shall, upon proper notice from OWNER, make all repairs in surfaces of trenches and excavations. All expenses incurred by OWNER and/or CONTRACTOR in making repairs and all expenses in maintaining trench and excavation surfaces shall be at the expense of CONTRACTOR regardless of the material used in backfilling trench excavations. OWNER reserves the right to make all emergency repairs necessary to make safe all streets and walks at the expense of CONTRACTOR regardless of the material used in backfilling trench excavations. A maintenance guarantee fund, if specified, will be withheld from the final amount due CONTRACTOR for a period of 6 months, after acceptance of the Work, to provide such maintenance.
- B. CONTRACTOR shall be responsible for controlling dust dispersion during utility and street construction. Remedial actions required as a result of inadequate dust control shall be CONTRACTOR's responsibility. To control dust, CONTRACTOR shall apply calcium chloride or ammonium lignin sulfonate in 12 to 14% solution or other dust control palliative acceptable to OWNER. Prior to application of dust palliative, the street shall be graded smooth.

3.09 POTENTIALLY HAZARDOUS WASTE

- A. If CONTRACTOR encounters during excavation or trenching activities any potentially hazardous waste as defined in this section, and the materials are within the limits of the site excavation or trenching work, the materials shall be handled as specified in this section. Potentially hazardous waste is defined as any drums, containerized waste, or organic liquid waste or surrounding impacted material. Such materials have not been found during investigations performed to date but could potentially be encountered.
- B. Should potentially hazardous waste be encountered, excavation activities in that portion of the site shall be placed on standby pending removal of the material, receipt of test results, and determination by the DNR and OWNER on whether work may proceed. It is anticipated that this standby time will be approximately 48 hours per occurrence, exclusive of weekends and holidays.
- C. Potentially hazardous waste defined above shall be carefully excavated, stockpiled, and tested to determine if they exhibit the characteristics of a hazardous waste as defined by the Title 35 Illinois Administrative Code, Parts 700–739.. Such materials shall be handled according to applicable IEPA, USEPA, and OSHA regulations and shall be stockpiled in a “Temporary Excavated Material Storage Area” as specified in Division 01. Stockpiling shall meet the requirements of NR 700.

3.10 CLEAN CONSTRUCTION OR DEMOLITION DEBRIS

- A. CONTRACTOR shall comply with 35 Ill. Adm. Code 1100 when disposing of clean construction or demolition debris (CCDD) or uncontaminated soil at a CCDD or uncontaminated soil fill operation.
- B. None of the Drawings, Specifications, or geotechnical reports shall be considered a guarantee that excavated material shall meet the requirements of 35 Ill. Adm. Code 1100, and CONTRACTOR shall be responsible for satisfactory removal and disposal of all material as specified herein. No additional environmental testing of the existing on-site material may

be performed without the written permission of OWNER, CONTRACTOR shall be required to properly and legally dispose of all material from the project site, regardless of its suitability for disposal in a CCDD facility, at CONTRACTOR'S expense, without any additional payment for testing, hauling, and disposal as specified below.

- C. CONTRACTOR shall consult at least three CCDD facilities for confirmation of acceptance of material from this project prior to submitting a bid for this project. CONTRACTOR shall base its bid on hauling all CCDD generated by this project and shall provide the name, location, and contact information of intended facilities to OWNER upon award of Contract to CONTRACTOR. No additional compensation will be allowed for hauling to any other facilities, for any reason, unless none of the indicated facilities will accept the material. In the case where none of CONTRACTOR's indicated facilities will accept the material, CONTRACTOR shall attempt to locate an alternate facility, unless the material is classified as unsuitable for disposal in a CCDD facility, in which case it shall be hauled to a landfill and paid for as specified below. Any costs associated with additional sampling, analysis, and/or reporting to meet the acceptance requirements of an intended facility shall be borne by the bidding CONTRACTOR and included within CONTRACTOR's bid. By submitting a bid, CONTRACTOR agrees that the intended facilities will accept the material and shall be used for disposal of all CCDD from this project, unless otherwise determined to be non-hazardous special waste as specified below. In the event that CONTRACTOR needs to alter the CCDD facility used for placement of excavated material, CONTRACTOR shall notify OWNER no less than three days in advance of the planned alteration. In no event shall material be hauled to an alternate facility without the written permission of OWNER.
- D. Construction Requirements:
1. CONTRACTOR shall be responsible for satisfactory removal and disposal of all waste material, asphalt, concrete, stone, dirt, and debris generated or discovered in the course of the work. Removal and disposal of excavation items being disposed of at a CCDD facility shall meet the requirement of 35 Ill. Adm. Code 1100. This work shall be incidental and shall not be paid for separately, with the exception of the NON-CCDD MATERIAL DISPOSAL as specified below.
 2. If material is rejected at the CCDD facility, it shall be returned to the project site and quarantined for further evaluation. No additional compensation shall be allowed for returning a reject load back to the project site or for any other additional hauling, loading, unloading, etc. as may be required. Should it be determined that the material is not suitable for disposal in a CCDD facility, CONTRACTOR shall be responsible for properly disposing of the material at an acceptable landfill and providing OWNER with all the proper paperwork to document the material disposal with the IEPA. This work shall be paid for as specified below.
 3. All work to satisfy these requirements shall be the responsibility of CONTRACTOR. All costs associated with meeting these requirements shall be included in CONTRACTOR's bid for installation of the associated pipe or structure. These costs shall include, but are not limited to, all required testing, lab analysis, and certification by a licensed professional engineer (PE) or licensed professional geologist (PG), if required, in addition to the cost of additional hauling, dump fees, etc.
 4. CONTRACTOR shall INCLUDE in its Bid the cost of removing, hauling, and disposing of in a licensed landfill 20 tons of excavated solid waste fill material not suitable for disposal in a CCDD facility. The cost shall include excavation, any testing required by the landfill, transportation, additional safety considerations, and disposal fees. Payment for non-CCDD material excavation and disposal will be adjusted, add or deduct, based upon the actual amount of fill material excavation and disposal (more or less than 20 tons) at the unit price for REMOVAL AND DISPOSAL OF NON-CCDD MATERIAL.

5. Landfill tonnage shall be based on weight tickets. Copies of all weight tickets for landfilled material shall be provided to OWNER for documentation purposed to calculate actual quantities. Weight tickets shall be duly and accurately completed. Weight tickets with incomplete or illegible information shall not be acceptable.

END OF SECTION

SECTION 32 31 15

WOOD FENCE

PART 1–GENERAL

1.01 SUMMARY

- A. Work Included: Wood fences (with gate).
- B. Related Sections and Divisions:
 - 1. Applicable provisions of Division 01 shall govern work in this section.
 - 2. See Section 05 50 00–Metal Fabrications.

1.02 REFERENCES

- A. ASTM A526–Steel Sheet Zinc Coated (Galvanized by the Hot Dip Process).
- B. ASTM B117–Salt Spray Testing.

PART 2–PRODUCTS

2.01 ACCEPTABLE MANUFACTURERS

- A. Acceptable manufacturers include the following, or equal: Qualline Fence Corporation (www.quallinefence.com).

2.02 WOOD FENCE MATERIALS

- A. Fence shall be manufactured from Western Red Cedar.
- B. Structural posts shall be 3-inch-diameter Schedule 40 galvanized steel. Structural posts shall run from the top of the fence to a minimum of 3 feet 6 inches below grade.
- C. Structural posts shall be sheathed in wood on all four sides and capped with wood.
- D. Gates shall be fabricated with galvanized steel frames and wood panels to match fence material. Gate shall be swing style with side frame upright members and rail intersection joined by welding. Gate side posts shall be minimum 4-inch-diameter Schedule 40 galvanized steel. Provide bottom gate catch for open gate and latch which can be fitted with a padlock.
- E. Wood fence shall be fitted with closely fitted vertical boards (to block direct view). Height of wood fences shall be 6 feet.

PART 3-EXECUTION

3.01 INSTALLATION OF WOOD FENCES

- A. Structural fence posts shall be approximately 6 feet on center with posts cast into 12-inch-diameter footings. Footings shall extend 3 feet 6 inches below grade.
- B. Fence panels and gates shall be attached to posts using panel brackets, hinges, and fasteners supplied by fence manufacturer.

END OF SECTION

SECTION 32 92 00

RESTORATION

PART 1–GENERAL

1.01 SUMMARY

- A. Work Included:
 - 1. Placement of Topsoil.
 - 2. Seeding.
 - 3. Fertilizer.
 - 4. Mulching.
 - 5. Maintenance.
- B. All areas disturbed by construction shall be restored. Backslopes adjacent to the sidewalk shall be seeded to the slope intercept.
- C. Related Sections and Divisions: Applicable provisions of Division 01 shall govern work in this section.
- D. Payment: Payment for restoration shall be at the Lump Sum Price Bid. Costs for topsoiling, seeding, fertilizer, mulching, and maintenance of restored areas shall be included in the lump sum price bid. One percent of the total Contract price shall be retained following project completion until a uniform 2-inch growth of vegetation is established over all restored areas.

1.02 REFERENCES

- A. Standard Specifications: Unless otherwise indicated, Standard Specifications shall refer to the State of Illinois Department of Transportation, Standard Specifications for Road and Bridge Construction, current edition, including all issued supplemental specifications.

1.03 QUALITY ASSURANCE

- A. All work shall be in accordance with Standard Specifications, unless noted otherwise.

PART 2–PRODUCTS

2.01 TOPSOIL

- A. Topsoil: Fertile, agricultural soil, typical for locality, capable of sustaining vigorous plant growth, taken from drained site; free of subsoil, stones greater than 3/4 inch in size, clay or impurities, plants, weeds and roots; pH value of minimum 5.4 and maximum 7.0.
- B. Topsoil from the site may be used if it meets the above requirements.

2.02 SEED

- A. Seed mixture shall be Class 2 per Article 250.07.

2.03 FERTILIZER

- A. Fertilizer shall be as specified in Article 250.

PART 3—EXECUTION

3.01 TOPSOIL

- A. Placing topsoil shall be in accordance with Article 211 of the Standard Specifications. Topsoil shall be placed to a uniform depth of 6 inches in place. Topsoil placement shall be incidental to sodding or seed, fertilizer, and mulching.

3.02 SEEDING

- A. Seeding shall be performed in accordance with Article 250 of the Standard Specifications.
- B. Seed shall be applied at the rates specified in Article 250 of the Standard Specifications.

3.03 FERTILIZER

- A. Fertilizer shall be applied per Article 250 of the Standard Specifications.

3.04 MULCHING

- A. All areas receiving seed shall be mulched.
- B. Mulching shall be performed in accordance with Method 2, Procedure 1 of Article 251 of the Standard Specifications.

3.05 MAINTENANCE

- A. Seeding/sodding shall proceed concurrently with construction. Seeding/sodding shall be maintained by CONTRACTOR until grass is well established. Grass is well established when it covers the entire seeded areas to a height of 2 inches.
- B. Mow sod at regular intervals to maintain at a maximum height of 2 1/2 inches. Do not cut more than 1/3 of grass blade at any one mowing.
- C. Immediately remove clippings after mowing.
- D. Water to prevent seed/sod and soil from drying out.
- E. Roll surface to remove minor depressions or irregularities.
- F. Control growth of weeds. Apply herbicides in accordance with manufacturer's instructions. Remedy damage resulting from improper use of herbicides.
- G. Immediately reseed areas which fail to show adequate catch. Bare spots shall not exceed 5 square feet in area and not exceed 3% of the total seeded areas.

- H. Immediately replace sod in areas which show bare spots or deterioration.
- I. Protect seeded areas with warning signs during maintenance period.
- J. Correct damage resulting from erosion, gullies, rills, or other causes by filling with topsoil, tamping, refertilizing, and reseeding or resodding if damage occurs prior to acceptance of work.

END OF SECTION

SECTION 33 52 16

FUEL GAS DISTRIBUTION UTILITIES

PART 1–GENERAL

1.01 SUMMARY

- A. This section contains specifications for all fuel utility distribution systems for this project.
Work included:
 - 1. Natural Gas Service.
 - 2. Natural Gas–Aboveground.
 - 3. Buried Natural Gas Piping.
 - 4. Vents and Relief Valves.
 - 5. Unions and Flanges.

1.02 CODES AND STANDARDS

- A. The latest published edition of a reference shall be applicable to this Project unless identified by a specific edition date.
- B. All material, installation, and workmanship shall comply with the applicable requirements and standards addressed within the following references.
 - 1. 2021 Fuel Gas Code with local amendments.
 - 2. NFPA 54–National Fuel Gas Code (Current Edition).
 - 3. Polyethylene gas distribution piping shall be installed in accordance with CFR 49, Part 192, Subpart G (mains), Subpart H (service lines), applicable codes and regulations, and ASTM D2774.

1.03 WELDER QUALIFICATIONS

- A. Before any polyethylene fusion welding is performed, Contractor to submit certification that the welders to be used on this project have successfully demonstrated proper welding procedures in accordance with the Code of Federal Regulations, Title 49, Part 192, Section 192.285.
- B. OWNER reserves the right to test the work of any welder employed on the project, at CONTRACTOR's expense. If the work of the welder is found to be unsatisfactory, the welder shall be prevented from doing further welding on the project.

1.04 NATURAL GAS SERVICE

- A. All charges for the gas service as shown on the Drawings, including the connection from the main in the street or other location to the gas meter, shall be paid by CONTRACTOR, including setting of gas meter(s) and all work performed by the gas company.
- B. The Utility Company is Nicor Gas. The natural gas utility provider contact information obtained during design is Christina Booker at (779) 208-7795, chbooker@southernco.com. CONTRACTOR is responsible to verify this information as well as installing and coordinating all aspects of the natural gas service.

- C. The secondary service pressure after the utility provided meter will be 2 psig, 1,670,000 BTU minimum, for the generator (standby power).
- D. No allowance shall be included by CONTRACTOR in the Lump Sum Bid for the scope of work provided by the Utility. Utility shall open trench natural gas from service to meter at no cost to OWNER. Coordinate the natural gas service with the Utility. This allowance shall be adjusted by change order (up or down), based on the actual cost of the natural gas service from the Utility to CONTRACTOR.

PART 2-PRODUCTS

2.01 NATURAL GAS-ABOVEGROUND

- A. See Section 23 11 23-Facility Fuel Gas Piping for specifications.

2.02 BURIED NATURAL GAS PIPING

- A. Manufacturers: Performance Pipe, a division of Chevron Phillips Chemical Company LP, JM Eagle, or equal.
- B. Buried natural gas pipe tubing, fittings, and joints shall be PE 2708 (PE 2406) polyethylene, SDR-11 or less, ASTM D2513 and D3350 pipe and fittings. Provide butt-weld fittings conforming to ASTM D3261 or socket-type fittings conforming to ASTM D2683.
- C. Polyethylene pipe tubing, fitting, and joint materials shall be compatible and by same manufacturer. Fabricated fittings shall not be used. Match fittings to service rating of pipe.
- D. Provide an anodeless riser connection between buried plastic gas service piping and metallic riser in accordance with the local codes. Provide a metallic riser consisting of HDPE fused coating on steel pipe for connection to aboveground building distribution piping. Underground horizontal metallic portion of riser shall be at least 24 inches in length before connecting to the plastic service pipe. An approved transition fitting or adaptor meeting design pressure rating and plastic pipe manufacturers recommendations shall be used where the plastic joins the metallic riser. Provide Elster, George Fischer Central Plastics, or equal.
- E. Gas Transition Fittings: Provide manufactured steel transition fittings approved for joining steel and polyethylene pipe, conforming to AGA XR0603 requirements for transition fittings. Transition fittings shall be manufactured by Continental, Elster, George Fischer Central Plastics, or equal.
- F. Underground installation of piping shall conform with ASTM D2774.
- G. Provide tracer wire as specified.

2.03 VENTS AND RELIEF VALVES

- A. Use pipe and pipe fittings as specified for the system to which the relief valve or vent is connected.

2.04 UNIONS AND FLANGES

- A. See Section 23 11 23–Facility Fuel Gas Piping for aboveground system specifications.
- B. Do not use flanges for underground gas or oil systems. Use fittings that are solvent-welded or fusion-bonded joints only.

PART 3–EXECUTION

3.01 INSTALLATION

- A. Gas piping shall be installed in accordance with state, local, and utility codes and the National Fuel Gas Code, NFPA No. 54. All natural gas piping shall be tested in accordance with all state, local, and utility codes pertaining to natural gas service or service requirements. CONTRACTOR shall arrange for natural gas service and shall coordinate service size and location and shall furnish and install all shutoff valves and pressure reduction as required.
- B. CONTRACTOR shall excavate and lay all pipe to the line and grade shown on the Drawings. Grade stakes will be required for all lines.
- C. Where piping is laid in native soil, the width of trench below the top of the pipe shall not exceed the nominal diameter of the pipe plus 2 feet for all pipelines. Where the maximum trench width is exceeded, the pipe shall be placed in a concrete cradle or a stronger pipe used. If the maximum trench width is exceeded for any reason other than as otherwise specified, the concrete cradle or the stronger pipe shall be placed at CONTRACTOR’s expense, unless CONTRACTOR can demonstrate that the pipe to be used is compatible with the resulting load applied.
- D. Thermoplastic pressure piping may be bedded in compacted sand. CONTRACTOR shall perform all necessary excavation and shall provide all required materials to provide this bedding. Bedding material shall conform to the requirements of ASTM C33. The material shall be hard, tough, and durable and shall meet the following gradation requirements.

PERCENTAGE BY WEIGHT PASSING

	Bedding Sand
1 inch	---
3/4 inch	---
1/2 inch	---
3/8 inch	100
No. 4	95 to 100
No. 8	80 to 100
No. 30	25 to 60
No. 100	5 to 20
Passing No. 200	2 to 10

- E. No materials native to the trench shall be used as bedding material unless they meet the above specifications.

- F. When piping is installed during hot weather, it shall be laid in the trench with slack or permitted to cool to ground temperature before it is cut to length for making final connections. PVC expansion joints shall be provided where needed.
- G. Trenches shall be kept water-free and dry during bedding, laying, and jointing. CONTRACTOR shall provide, operate, and maintain all pumps or other equipment necessary to drain and keep all excavation pits and trenches and the entire subgrade area free from water under any and all circumstances that may arise.
- H. Material that is to be placed from the bedding material around and to 1 foot above the top of all pipes shall be termed cover material. Except as otherwise specified, (a) cover material shall consist of durable granular particles ranging in size from fine to coarse in a substantially uniform combination, (b) unwashed bank-run sand and crushed bank-run gravel will be considered generally acceptable for cover material, (c) no stones larger than 3/4 inch in their greatest dimension shall be allowed in the cover material, and (d) native materials may be used if they conform to the above specifications. Cover material for copper piping shall be sand. Cover material for PVC pressure or other thermoplastic piping may be sand.
- I. Cover material shall be deposited in the trench for its full width on each side of the pipe, fittings, and appurtenances simultaneously. Cover material shall be placed over the top of the pipe to the height as shown on Drawing 01-975-43A for Class "B" (minimum 12 inches) or Class "C" (minimum 6 inches) Bedding. This backfill shall be placed by hand in 6-inch layers and shall be compacted using hand tamping bars and/or mechanical tampers. If bedding material conforming to any of the above three crushed stone or crushed gravel gradations is used as cover material, it need not be tamped. The remaining 6 inches to make up the required 1 foot of select cover material for Class "C" Bedding shall be granular material specified previously with no stones larger than 3/4 inch.
- J. All cover material shall be placed in maximum 6-inch layers and compacted by hand tamping. Compaction shall be equivalent to that described under "Compacted Fill and Backfill" as specified in Section 31 23 00–Excavation, Fill, Backfill, and Grading.
- K. Except as otherwise specified, all backfill above 1 foot above the pipe shall be "Compacted Fill and Backfill" as specified in Section 31 23 00–Excavation, Fill, Backfill, and Grading.
- L. The locations and elevations of existing piping and manholes are approximate. Where necessary, existing piping shall be exposed by CONTRACTOR to confirm location and elevation before installing new piping. Any changes in pipe location or elevation shall be approved by OWNER.
- M. Install an electrically conductive 10 gauge copper wire with yellow insulation with buried natural gas piping. The tracer wire shall be installed at a distance of 4 inches to 6 inches adjacent to the pipe. The wire and all of its connections shall be insulated to prevent corrosion.
- N. Do not install natural gas piping in same trench with other utilities. Minimum horizontal clearance between gas pipe and parallel utility pipe shall be 2 feet. Natural gas pipe shall not be installed through catch basins, vaults, manholes or similar underground structures.
- O. Natural gas entrances into buildings shall be above grade.

- P. Protection Against Shear and Bending Loads: In accordance with ASTM D2774, natural gas connections shall be protected where an underground polyethylene branch or service pipe is joined to a branch fitting such as a service saddle, branch saddle, or tapping tee on a main pipe, and where pipes enter or exit casings or walls. The area surrounding the connection shall be embedded in properly placed, compacted backfill, preferably in combination with a protective sleeve or other mechanical structural support to protect the polyethylene pipe against shear and bending loads.
- Q. Butt, socket, and saddle fusion joints in polyethylene natural gas piping shall be made using procedures that have been qualified and approved by the Operator in accordance with Title 49, CFR, and Part 192.283.
- R. In accordance with CFR. 49, part 192, Section 192.285, the Operator shall review that all persons making heat fusion joints have been qualified to make joints in accordance with the Operator's Approved Qualified Fusion Procedures. The Operator shall maintain records of qualified personnel, and shall certify that qualification training was received not more than 12 months before commencing construction. CONTRACTOR shall review that all persons making heat fusion joints are qualified in accordance with this section.
- S. Butt fusion of unlike wall thickness: Butt fusion shall be performed between pipe ends, or pipe ends and fitting outlets that have the same outside diameter and are not different in wall thickness by more than one Standard DR. Transitions between unlike wall thickness greater than one SDR shall be made with a transition nipple or by mechanical means or electrofusion.
- T. Polyethylene natural gas pipe and fittings may be joined together or to other materials by transition fittings, fully restrained mechanical couplings, or electrofusion. These devices shall be designed for joining polyethylene to another material and shall be approved by ENGINEER for use in natural gas distribution system.
- U. When mechanical OD compression couplings are used, polyethylene natural gas pipe shall be reinforced with a stiffener in the pipe bore. Stiffeners shall be properly sized for the diameter and wall thickness of polyethylene pipe being joined. For service pipe connections, the stiffener length shall match the pipe end penetration depth into the coupling.
- V. General Excavation:
1. CONTRACTOR shall do all excavation, undercutting, dewatering, and backfilling necessary for work under this contract unless otherwise noted. All trees, shrubs, and improved areas outside the excavation shall be protected from damage.
 2. Work shall conform to other sections of Division 31, except where modified by this section.
 3. Pipe shall be placed only on dry foundations. No extra payment will be made to CONTRACTOR for dewatering.
 4. Excavation shall include all necessary clearing of excavated areas, tree removal, all grubbing, all wet, dry, fill, and rock excavation, the removal of pavement, filling, and all incidental work such as tunneling, sheet piling, shoring, underpinning, pumping, bailing, transportation, and all fill and backfilling. All above work shall be included in the Lump Sum Bid.
 5. CONTRACTOR shall excavate whatever materials are encountered as required to place at the elevations shown, all pipe, manholes, and other work as required to complete the project as shown. The bottom of the excavation shall be leveled off, all loose and

disturbed soil shall be removed, and it shall be hand-tamped prior to pipe, manhole, etc., installation. Where requested by ENGINEER, original material below the excavation necessary for construction according to grades shown or specified shall be removed and replaced in accordance with Section 31 23 00–Excavation, Fill, Backfill, and Grading. Payment will also be in accordance with Section 31 23 00–Excavation, Fill, Backfill, and Grading.

6. The excavation at the crossing of all underground utility services in place shall be as narrow as practicable. All underground services shall be protected from damage and maintained in service at their original location and grade during the process of the work. Any damage to underground services shall be replaced or repaired at no cost to OWNER or to the owner of the service. The present underground services shown on the Drawings are located in accordance with available data. Encountering these services at a different location or encountering services not shown shall not release CONTRACTOR from the above-stated conditions.
 7. Excavated native material that is unsuitable or not required for filling shall be removed from the site. Materials to be used for fill and suitable for this purpose shall be deposited where required except that no fill shall be placed where trenches for sewers, water lines, or other services will be located until after the trench work is completed.
 8. CONTRACTOR shall provide adequate shoring, sheet piling, and bracing to prevent earth from caving or washing into the excavation and shall do all shoring and underpinning necessary to properly support adjacent or adjoining structures. All shoring, sheet piling, and underpinning must be maintained until permanent support is provided.
 9. Any water, drainage, gas, sewer, or electric lines encountered in the excavation that are not to be disturbed shall be properly underpinned and supported. Any service connections encountered that are to be removed shall be cut off at limits of the excavation and capped in accordance with the requirements of or permits governing such removals. Any permits required for this work will be obtained by OWNER upon request of CONTRACTOR.
- W. Gas lines shall not be installed under buildings, structures, or in crawl spaces.
- X. A Schedule 40 steel sleeve shall be installed on all natural gas risers passing through asphalt or concrete slabs. Allow at least 1 inch of radial clearance between sleeve and riser. Void shall be filled with pea gravel.
- Y. Natural gas piping shall be buried a minimum depth of 36 inches, unless noted otherwise.
- Z. Do not route piping through sub-grade utility vaults.
- AA. Install all valves, and piping specialties, including items furnished by others, as specified and/or detailed. Make connections to all equipment installed by others where that equipment requires the piping services indicated in this section.
- BB. Pitch horizontal piping down 1-inch in 60 feet in the direction of flow to dirt leg that is to be located in building for accessibility. When installing mains and branches, cap gas-tight each tee or pipe end which will not be immediately extended. All branch connections to the main shall be from the top or side of the main.
- CC. Do not install gas pipe below a building or its foundation or in a ventilation air plenum.

- DD. If an above ground vent terminates in an area subject to snow accumulation, terminate the line at least 5 feet above grade.
- EE. All joints in underground polyethylene gas pipe must be made by qualified personnel proficient in the joining methods of ASTM D2513 thermoplastic gas pressure pipe and polyethylene fittings. Do not install polyethylene gas pipe inside buildings.
- FF. Install shut off valves as shown on Drawings. Provide valve box and valve operator per NFPA and AGA standards.
- GG. Blow compressed air into gas piping system as a part of commissioning system, before placing into service, to clean piping until target cloth is clean and free of debris.
- HH. Use for all underground metallic piping or underground metallic gas conduit.
- II. Remove all dirt and other foreign material from exterior of pipe. Apply primer as recommended by the manufacturer. Use a spiral wrap process for applying tape to the pipe. Repair any breaks in the tape coating caused by the installation process.
- JJ. Concealed or underground unions or flanges are not acceptable.

3.02 FIELD QUALITY CONTROL

- A. If required for the additional pressure load under test, provide temporary restraints at expansion joints or isolate them during the test. Verify that hangers can withstand any additional weight load that may be imposed by the test.
- B. Provide all piping, fittings, blind flanges, and equipment to perform the testing.
- C. Conduct pressure test with test medium of air unless specifically indicated. Minimum test time is indicated in the table below; additional time may be necessary to conduct an examination for leakage. Each test must be witnessed by the Division's representative. If leaks are found, repair the area with new materials and repeat the test; caulking will not be acceptable.
- D. Do not backfill pipe until it has been successfully tested.
- E. For air tests, gradually increase the pressure to not more than one half of the test pressure; then increase the pressure in steps of approximately one-tenth of the test pressure until the required test pressure is reached. Examine all joints and connections with a soap bubble solution or equivalent method. The piping system exclusive of possible localized instances at pump or valve packing shall show no evidence of leaking. After testing is complete, slowly release the pressure in a safe manner.
- F. Measure natural gas system test pressure with a water manometer or an equivalent device calibrated in increments not greater than 0.1 inch water column. System will not be approved until it can be demonstrated that there is no measurable loss of test pressure during the test period.

System	Pressure	Medium	Duration
Natural gas	100 psig	Air	24 hr

- G. On piping that cannot be tested because of connection to an active line, provide temporary blind flanges and hydrostatically test new section of piping. After completion of test, remove temporary flanges and make final connections to piping. Die penetrate test pass weld or x-ray the piping that was not hydrostatically tested up to the active system.

END OF SECTION

SECTION 33 52 26

NATURAL GAS CONTRACTOR QUALIFICATION REQUIREMENT

PART 1–GENERAL

1.01 SUMMARY

- A. This section specifies the requirements for CONTRACTOR qualifications including a list of all covered tasks for this project and the required Contractor Personnel Qualification Program (CPQP) that is to be submitted with the Bid and maintained throughout construction.

1.02 MEASUREMENT AND PAYMENT

- A. Unless otherwise stated in the Bid Form, no separate payment will be made for work performed under this specification. Unless otherwise stated in the Bid Form, all costs shall be included in the related items of work listed in the Bid Form.

1.03 PROGRAM DESCRIPTION

- A. CONTRACTOR is required to have an in-house Contractor Personnel Qualification Program (CPQP) that is acceptable to OWNER. The CPQP shall be submitted with the Bid as noted herein and is subject to the review of OWNER during the evaluation of the Bids and throughout the duration of the project. CONTRACTOR shall have qualified personnel that are capable of performing the covered tasks listed in this specification. OWNER has sole discretion in evaluating the qualifications of all CONTRACTOR personnel during the evaluation of the Bids and throughout the duration of construction.

1.04 SUBMITTALS

- A. Information to be Submitted With Bid. Each contractor shall submit documentation of a Contractor Personnel Qualification Program (CPQP) with their Bid. The CPQP shall contain all required information as described herein (See Paragraph 3.01, Below). OWNER reserves the right to reject any Bid that does not include a CPQP. OWNER also has sole discretion in evaluating and determining the suitability of the CPQP submitted with the Bid and may elect to reject a Bid if, in OWNER's opinion, the CPQP is not acceptable.
- B. Information to be Submitted Following Bid. OWNER reserves the right to request additional information from CONTRACTOR pertaining to the Contractor Personnel Qualification Program (CPQP) after a Bid is submitted and during Construction. CONTRACTOR shall provide OWNER with all updates to the CPQP throughout the duration of the project in accordance with Paragraph 3.01.B of this specification.

PART 2–PRODUCTS

NOT APPLICABLE

PART 3–EXECUTION

3.01 CONTRACTOR PERSONNEL QUALIFICATION PROGRAM (CPQP)

- A. General: CONTRACTOR shall have an in-house Contractor Personnel Qualification Program (CPQP) that is acceptable to OWNER and shall submit the CPQP as described in this specification (See Paragraph 1.06–SUBMITTALS). The CPQP is required so that OWNER can review the qualification of CONTRACTOR personnel under their own Operator Qualification Program. The CPQP shall contain all necessary information on the qualifications of CONTRACTOR personnel that will be responsible for performing the covered tasks that are to be done during the execution of the work required for this project. The CPQP shall contain, but not be limited to, the following minimum information:
1. Name of qualified individual(s).
 2. Dates of qualifications for all personnel.
 3. Method of qualification for all personnel.
 4. Qualification expiration date for all personnel.
 5. Covered tasks that all personnel are qualified to perform.
- B. CONTRACTOR is also encouraged to submit any other information that will substantiate the qualifications of their personnel including work history, resumes, certifications, training schedules, safety programs, etc. The additional information will serve to assist OWNER in their Operator Qualification Program.
- C. CONTRACTOR is required to be familiar with and meet all rules promulgated by the United States Department of Transportation (DOT) as it pertains to personnel qualifications and drug testing.
- D. Updates to CPQP: CONTRACTOR shall update CPQP when requested by OWNER and when there are any changes in personnel assigned to complete the covered tasks associated with this project. Updates will also be provided when personnel are re-qualified for the various covered tasks listed herein.
- E. OWNER Authority: OWNER and their responsible personnel are hereby defined as the Operator of the gas system where the proposed improvements are to be constructed by CONTRACTOR.

3.02 SCHEDULE OF COVERED TASKS

- A. CONTRACTOR shall employ personnel that are qualified for the following tasks on this project:
1. Emergency valve inspection.
 2. Over-pressure protection device inspection.
 3. Regulator inspection.
 4. Cathodic protection pipe-to-soil readings.
 5. Correction of cathodic potential deficiencies.
 6. Installation of cathodic protection anodes and testing equipment.
 7. Rectifier inspection.
 8. Leakage survey.
 9. Above ground leak repair.
 10. Below ground leak repair.
 11. Welding on gas pipelines and appurtenances.

12. Joining of plastic pipe and appurtenances.
13. Visual inspection of pipe and pipe components for damage prior to installation.
14. Visual inspection of pipe and pipe components for correct pressure rating and correct application prior to installation on gas pipeline facilities.
15. Locating below ground pipeline facilities and marking the location of the facilities.
16. Installing and burying gas pipelines in a ditch.
17. Installing gas pipelines by bore.
18. Tapping gas mains.
19. Responding to gas emergencies after business hours.
20. Abandoning gas pipeline facilities.
21. Pressure testing gas pipeline facilities.

END OF SECTION

DRAWINGS

NOTES

1. DETAILS RELATIVE TO ITEMS SHOWN ON THIS DRAWING SHALL CONFORM TO THE PERTINENT REQUIREMENTS OF THE SPECIFICATIONS AND THE APPLICABLE SPECIAL PROVISIONS.
2. VARIATIONS IN DIMENSIONS AND DESIGN MAY BE PERMISSIBLE, PROVIDING EQUIVALENT CAPACITY AND STRENGTH ARE ATTAINED.
3. ALL CONCRETE FILLETS SHALL BE HAND TROWELED WITH A 1/4" FT. SLOPE.
4. INSIDE DIMENSIONS FOR MANHOLES: USE MINIMUM 4' DIAMETER FOR SEWER LESS THAN 18" IN DIAMETER; USE MINIMUM 5' DIAMETER FOR SEWER 18" THRU 24" IN DIAMETER; USE MINIMUM 6' DIAMETER OR MINIMUM 6' SQUARE FOR SEWER OVER 24" IN DIAMETER.
5. BEDDING CLASSES "B" AND "C" SHALL MEET OR EXCEED ASTM C12 REQUIREMENTS.
6. DROP TYPE ENTRANCE TO STANDARD MANHOLE WILL BE PAID FOR SEPARATELY IF SO LISTED IN THE BID.
7. SEE DRAWINGS FOR DROP TYPE ENTRANCES FOR SANITARY SEWERS LARGER THAN 15".
8. ALL WORK SHALL BE DONE IN ACCORDANCE WITH THE REQUIREMENTS OF REGULATORY BODIES OF THE STATE AND APPLICABLE MUNICIPAL ORDINANCES.
9. ALL NEW CONSTRUCTION SHALL BE PLACED ON UNDISTURBED EARTH OR STONE BEDDING.
10. FLAT SLAB TOPS SHALL BE DESIGNED FOR H-20 TRUCK LOADING AND SHALL MEET REQUIREMENTS OF ASTM C-478.
11. BASE SLABS SHALL BE REINFORCED AS FOLLOWS: REINFORCING SHALL BE PLACED IN EACH DIRECTION AT 2" CLEAR FROM TOP SURFACE OF SLAB. REINFORCING SHALL BE GRADE 60. USE OF CAST-IN-PLACE SLAB SHALL NOT RELIEVE CONTRACTOR OF REQUIREMENTS TO PROVIDE WATERTIGHT JOINTS.
12. FLAT SLABS SHALL BE PROVIDED IN SHALLOW DEPTH SITUATIONS IN LIEU OF ECCENTRIC CONES.

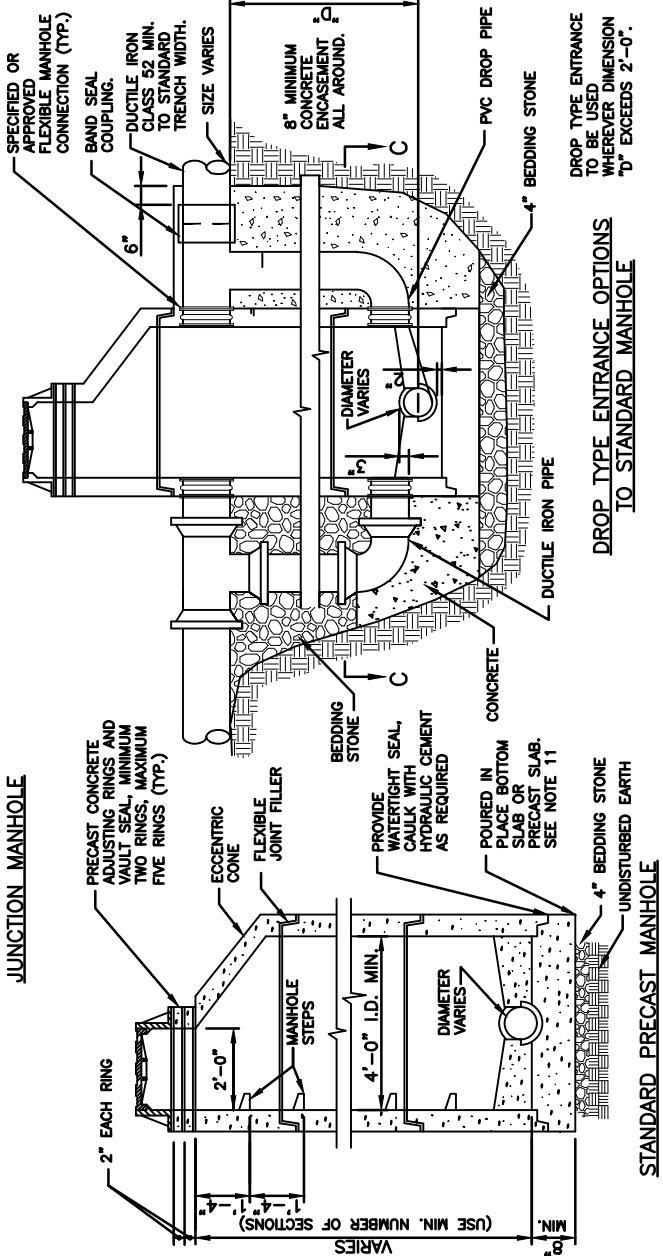
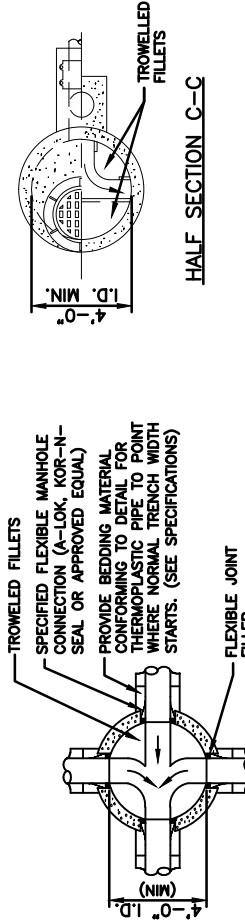
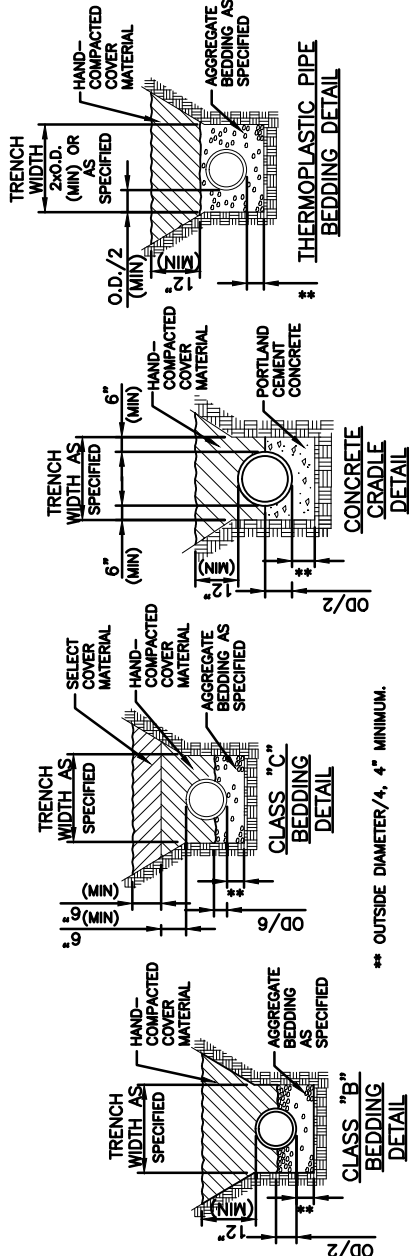

INSIDE DIA.	DEPTH	REINF.
4'	≤ 30"	#3@8"
5'	≤ 20"	#3@8"
5'	20'-30"	#4@10"
6'	≤ 20"	#4@10"
6'	20'-25"	#4@8"
6'	25'-30"	#4@6"

SANITARY SEWER APPURTENANCES
STANDARD DETAIL

STRAND ASSOCIATES
11-975-434
OCTOBER 2011

For more location information
please visit www.strand.com

Office Locations

Ames, Iowa | 515.233.0000

Brenham, Texas | 979.836.7937

Cincinnati, Ohio | 513.861.5600

Columbus, Indiana | 812.372.9911

Columbus, Ohio | 614.835.0460

Joliet, Illinois | 815.744.4200

Lexington, Kentucky | 859.225.8500

Louisville, Kentucky | 502.583.7020

Madison, Wisconsin* | 608.251.4843

Milwaukee, Wisconsin | 414.271.0771

Nashville, Tennessee | 615.800.5888

Phoenix, Arizona | 602.437.3733

*Corporate Headquarters

